

INPUT FLANGE DETAILS						
	FLANGE O/DIA & THICKNESS	SHAFT DIA.	RECESS DIA.	RECESS DEPTH	HOLE DETAILS (OFF CRS)	KEY DETAILS
ISO F16	Ø210 (Ø8.27") x 20 (0.79")	Ø40.00 -0.05 (Ø1.575" -0.002")	Ø130.05 +0.05 (Ø5.120" +0.002")	5 (0.20")	4 HOLES Ø20.5 (Ø0.81") ON Ø165.0 (Ø6.50") P.C.	12x8x55 (0.47"x0.31"x2.17")
FA16	Ø210 (Ø8.27") x 20 (0.79")	Ø40.00 -0.05 (Ø1.575" -0.002")	Ø126.92 +0.05 (Ø4.997" +0.002")	5 (0.20")	4 HOLES Ø20.5 (Ø0.81") ON Ø165.0 (Ø6.50") P.C.	12x8x55 (0.47"x0.31"x2.17")
ISO F25	Ø300 (Ø11.81") x 20 (0.79")	Ø50.00 -0.05 (Ø1.969" -0.002")	Ø200.10 +0.10 (Ø7.878" +0.004")	5 (0.20")	8 HOLES Ø16.5 (Ø0.65") ON Ø254.0 (Ø10.00") P.C.	14x9x55 (0.55"x0.35"x2.17")
FA25	Ø300 (Ø11.81") x 20 (0.79")	Ø50.00 -0.05 (Ø1.969" -0.002")	Ø152.37 +0.10 (Ø5.999" +0.004")	5 (0.20")	8 HOLES Ø16.5 (Ø0.65") ON Ø254.0 (Ø10.00") P.C.	14x9x55 (0.55"x0.35"x2.17")

BASEPLATE DETAILS (ALTERNATIVES AVAILABLE ON REQUEST)	
	HOLE DETAILS (OFF CRS)
ISO F40	8 HOLES M36x38 (1.50") DEEP ON Ø406.0 (15.98") P.C.
ISO F48	12 HOLES M36x38 (1.50") DEEP ON Ø483.0 (19.02") P.C.
ISO F60	20 HOLES M36x38 (1.50") DEEP ON Ø603.0 (23.74") P.C.

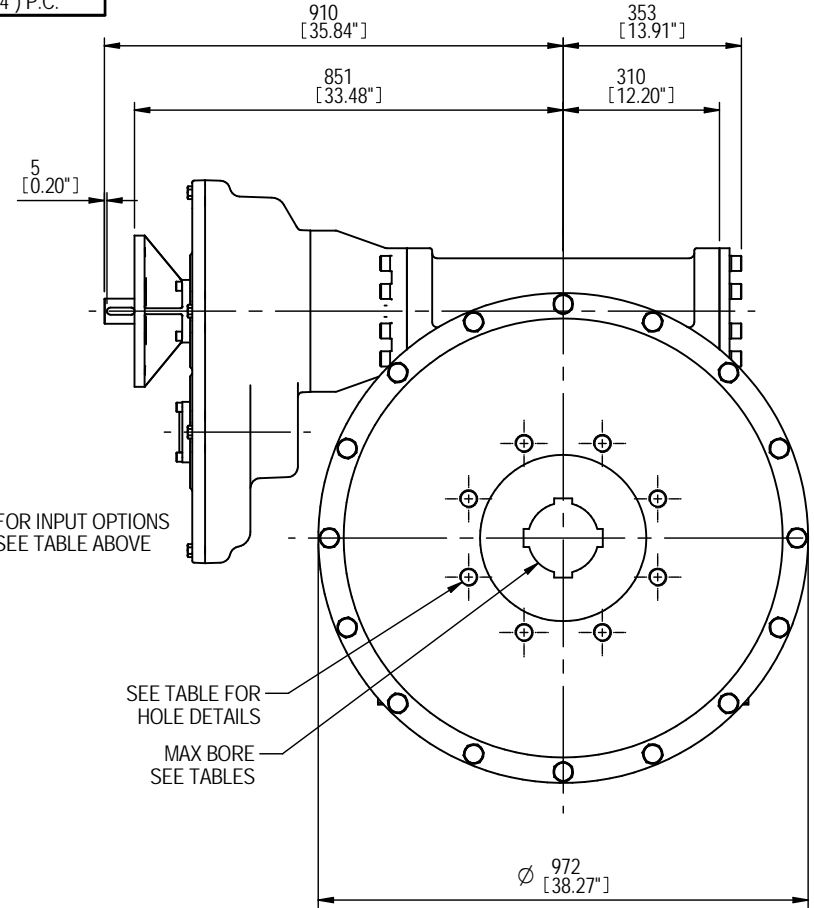
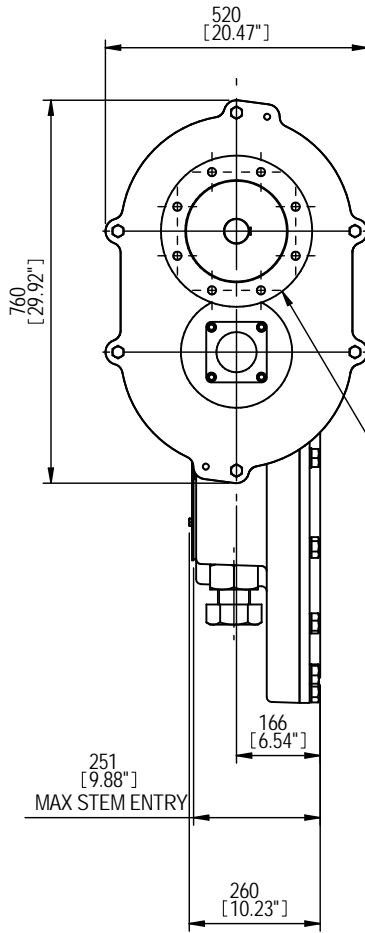
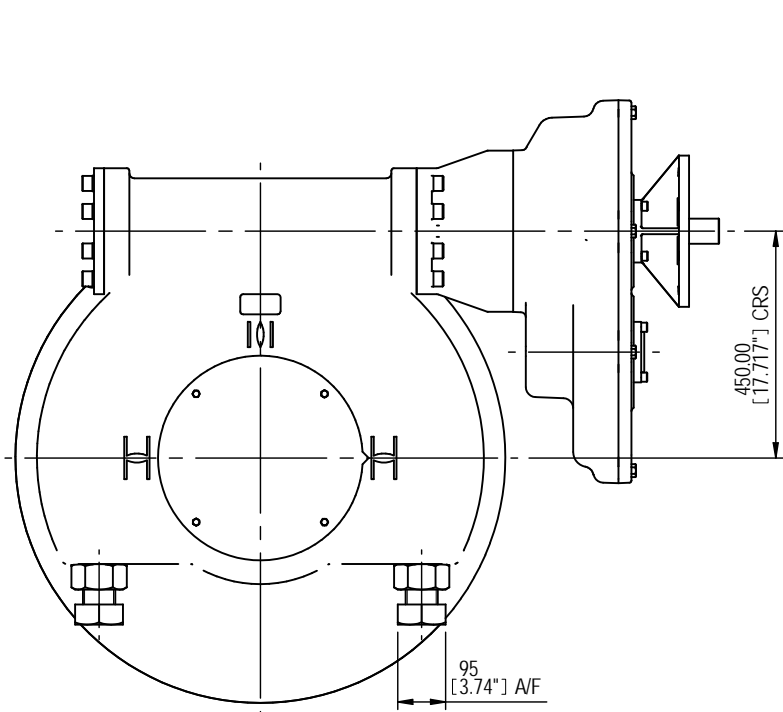

MAX BORE RECTANGULAR KEY				MAX BORE SQUARE KEY			
STD	BASE	BORE	KEY	STD	BASE	BORE	KEY
BS4235	F40	272	63 x 32	BS4235	F40	-	-
BS4235	F48 & F60	305	70 x 36	BS4235	F48 & F60	-	-
BS46	F40	10"	2.5" x 1.625"	BS46	F40	-	-
BS46	F48 & F60	12"	3" x 2"	BS46	F48 & F60	-	-
ANSI B17.1	F40	10.25"	2.5" x 1.75"	ANSI B17.1	F40	9.5"	2.5" x 2.5"
ANSI B17.1	F48 & F60	12"	3" x 2"	ANSI B17.1	F48 & F60	11.75"	3" x 3"

ROTORC GEARS
 REGINA HOUSE
 RING ROAD
 BRAMLEY
 LEEDS
 WEST YORKSHIRE

OUTLINE DETAILS OF IW12/IR4 240:1 TO 960:1 MOTORISED GEARBOX

DETAILS SUBJECT TO CHANGE WITHOUT PRIOR NOTICE

FOR UP TO DATE DETAILS VISIT www.rotork.com

ISSUE :-	2	SCALE :-	1 : 15 (A4)
DATE :-	18/01/2010		
DRAWING No :-	IW12CDS2		