

INPUT FLANGE DETAILS						
	FLANGE O/DIA & THICKNESS	SHAFT DIA.	RECESS DIA.	RECESS DEPTH	HOLE DETAILS (OFF CRS)	KEY DETAILS
ISO F25	Ø350 (Ø13.78") x 20 (0.79")	Ø75.00 -0.05 (Ø2.953" -0.002")	Ø200.10 +0.10 (Ø7.878" +0.004")	6 (0.24")	8 HOLES Ø16.5 (Ø0.65") ON Ø254.0 (Ø10.00") P.C.	2 KEYS 20x12x140 (0.79"x0.47"x5.51")
ISO F30	Ø350 (Ø13.78") x 20 (0.79")	Ø75.00 -0.05 (Ø2.953" -0.002")	Ø230.10 +0.10 (Ø9.059" +0.004")	6 (0.24")	8 HOLES Ø20.5 (Ø0.81") ON Ø298.0 (Ø11.73") P.C.	2 KEYS 20x12x140 (0.79"x0.47"x5.51")

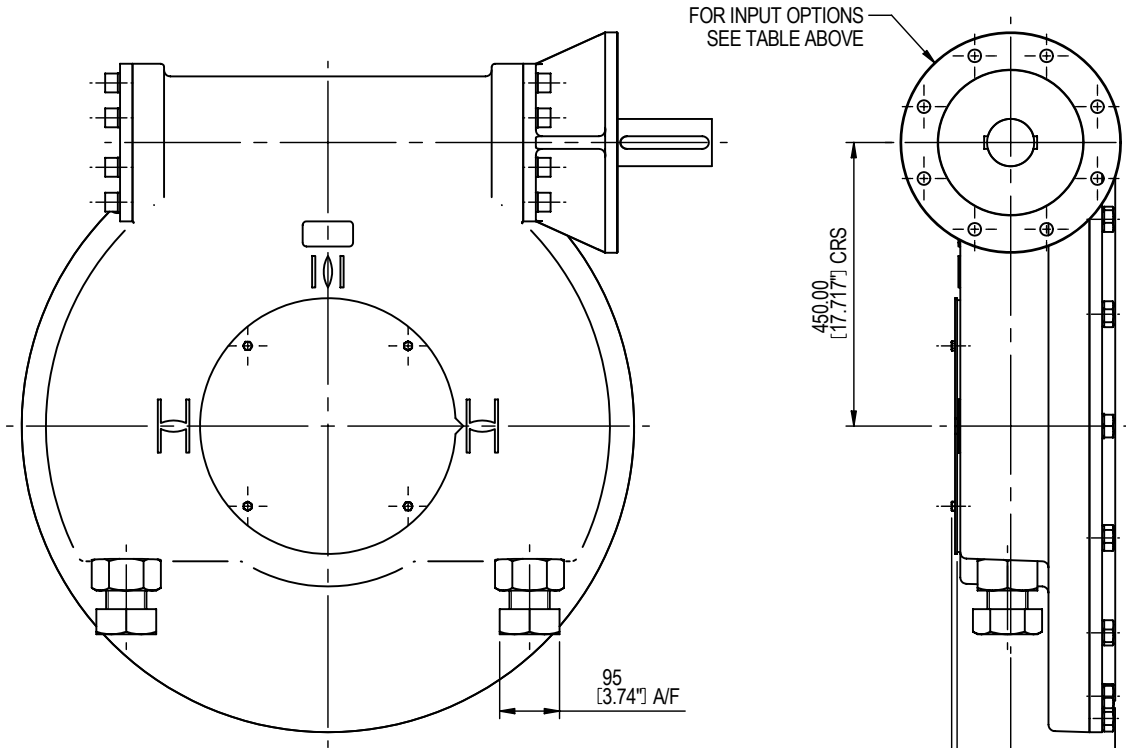

BASEPLATE DETAILS (ALTERNATIVES AVAILABLE ON REQUEST)	
	HOLE DETAILS (OFF CRS)
ISO F40	8 HOLES M36x38 (1.50") DEEP ON Ø406.0 (15.98") P.C.
ISO F48	12 HOLES M36x38 (1.50") DEEP ON Ø483.0 (19.02") P.C.
ISO F60	20 HOLES M36x38 (1.50") DEEP ON Ø603.0 (23.74") P.C.

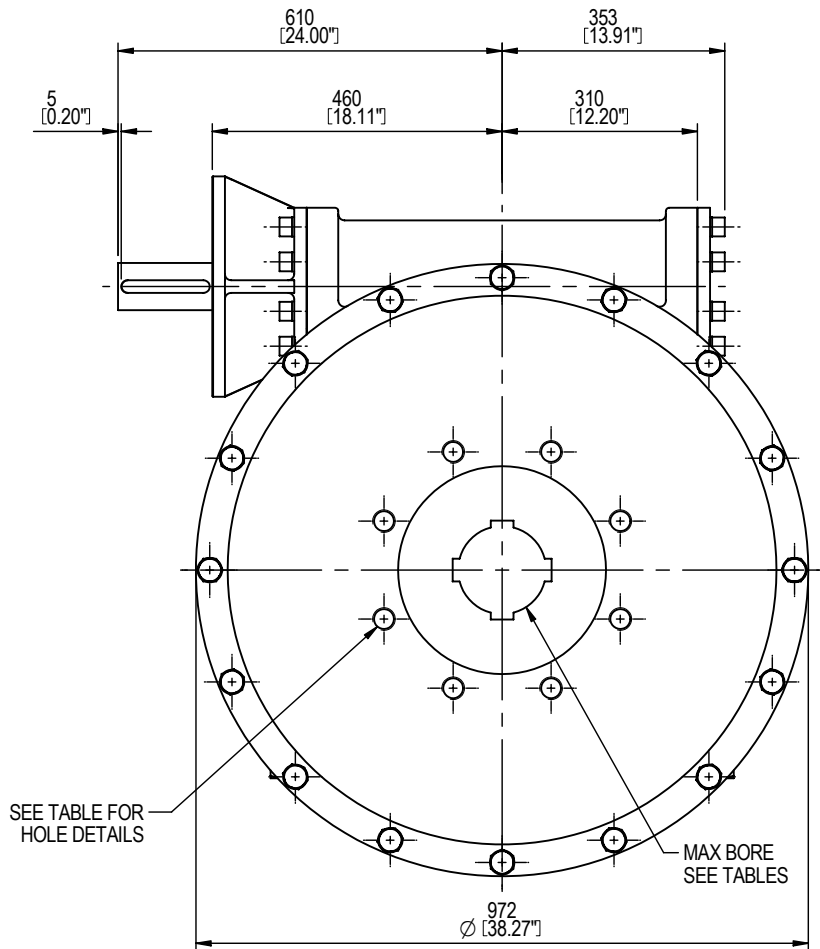

MAX BORE RECTANGULAR KEY				MAX BORE SQUARE KEY			
STD	BASE	BORE	KEY	STD	BASE	BORE	KEY
BS4235	F40	272	63 x 32	BS4235	F40	-	-
BS4235	F48 & F60	305	70 x 36	BS4235	F48 & F60	-	-
BS46	F40	10"	2.5" x 1.625"	BS46	F40	-	-
BS46	F48 & F60	12"	3" x 2"	BS46	F48 & F60	-	-
ANSI B17.1	F40	10.25"	2.5" x 1.75"	ANSI B17.1	F40	9.5"	2.5" x 2.5"
ANSI B17.1	F48 & F60	12"	3" x 2"	ANSI B17.1	F48 & F60	11.75"	3" x 3"

ROTORK GEARS

REGINA HOUSE
RING ROAD
BRAMLEY
LEEDS
WEST YORKSHIRE

OUTLINE DETAILS OF IW13 60:1 MOTORISED GEARBOX

DETAILS SUBJECT TO CHANGE WITHOUT PRIOR NOTICE

FOR UP TO DATE DETAILS VISIT www.rotork.com

ISSUE :-	A	SCALE :-	1 : 12 (A4)
DATE :-		30/01/2007	
DRAWING No :-		IW13CDS1	