

CIRCUIT DRAWN WITH
POWER SUPPLY OFF

THREE
PHASE
SUPPLY

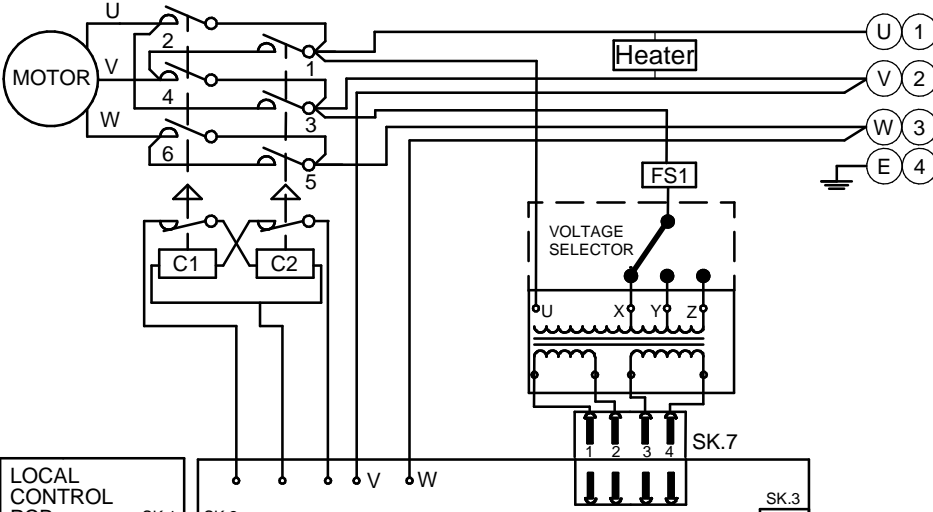

TRANSFORMER TAPPING

TAP	NOM 50/60HZ	50HZ	60HZ
X	220/230	176-242	198-259
Y	380/400	304-418	342-446
Z	440/460	352-484	396-517

FS1 - See ROMPAK PUB008-006 Installation and Maintenance Manual

NOTE

FOR TYPICAL REMOTE CONTROL INDICATING, MONITORING AND ALARM CIRCUITS SEE PUBLICATION DOC862

MAX EXTERNAL LOAD ON SIR RELAYS TO BE 5A. MAX VOLTAGE 120V AC/DC

MAX EXTERNAL LOAD ON TERMINAL 27 & 28 TO BE 3W

CONTROL SIGNAL THRESHOLD VOLTAGES:
MAX 60V DC
TO BE MINIMUM 'ON' 14V DC AT 1mA
MAXIMUM 'OFF' = 3V
MINIMUM CONTROL SIGNAL DURATION TO BE 300mS.

CURRENT DRAWN FROM EACH REMOTE CONTROL SIGNAL IS 5mA ON 24V DC

LS3 / LS4
MAXIMUM CURRENT 3A MAXIMUM VOLTAGE 120V AC/DC

ACTUATOR CONFIGURATION VIA DIL SWITCH SW2

ROM1 AND ROMA DO NOT SUPPORT TORQUE LIMIT

REFER TO INSTALLATION INSTRUCTIONS FOR DIL SWITCH SELECTION

NOT USED

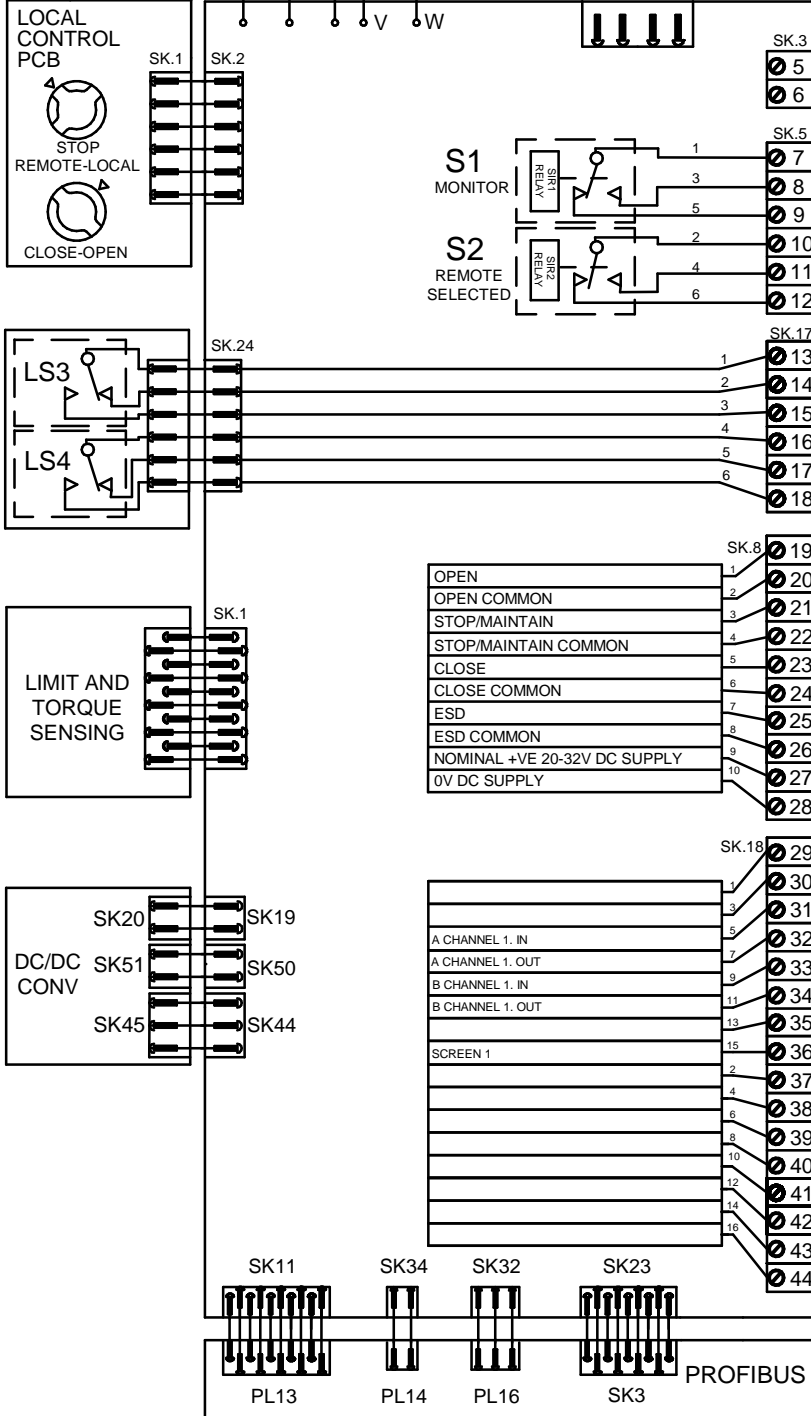

Iss	Date	Chkd	Revision Details
4	160414		Drawing layout and text change

www.rotork.com

ROTORK CONTROLS LTD BATH, BA1 3JQ ENGLAND Tel:01225-733200	ROTORK CONTROLS INC ROCHESTER NY 14624, USA Tel:585-247-2304
---	---

ROMPAK 3PH PROFIBUS+TORQUE SWITCHES

Drawn by: VYA Date : 16-Apr-14 Base WD: R000-600 Job No : - - MI No : - -	Circuit Diagram No R000-600	Issue No 4
---	---------------------------------------	----------------------