

DESCRIPTION:

TRAVEL : -5° TO 95° adjustable
 RATIO : 729 : 1
 TURNS TO CLOSE : 182.25
 WEIGHT : 134.4 kg. (295.7 lb.) Excl. handwheel

MOUNTING HOLES :

BOLT CIRCLE : min. ϕ 254 [10.00]
 (OFF CENTER) max. ϕ 356 [14.01]
 acc. ISO 5211 : F25-F30-F35
 MIN. bore Quadrant : ϕ 65 [2.56]
 MAX. bore Quadrant : ∇ 115 [4.52] or ϕ 160 [6.29]

TORQUE :

max. OUTPUT : 26000 Nm (230120 lbf.in.)
 max. INPUT : 124 Nm (1096 lbf.in.)
 MA : 210.0 \pm 15%

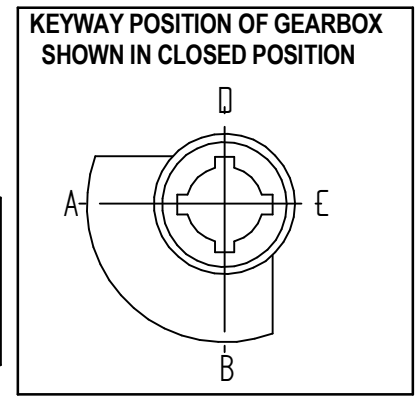

DIMENSIONS IN MM[INCH]