

DESCRIPTION:

TRAVEL : -5° TO 95° adjustable
 RATIO : 217 : 1
 TURNS TO CLOSE : 54.34
 WEIGHT : 52 kg. (114.4 lb.) Excl. handwheel

MOUNTING HOLES :

BOLT CIRCLE : min. Ø 125 [4.92]
 (OFF CENTER) : max. Ø 298 [11.73]
 acc. ISO 5211 : F12 - F14 - F16 - F25-F30
 Min. bore Quadrant : Ø 30 [1.18]
 MAX. bore Quadrant : ∇ 60 [2.36] or Ø 80 [3.15]

TORQUE :

max. OUTPUT : 7000 Nm (61955 lbf.in.)
 max. INPUT : 106 Nm (939 bf.in.)
 MA : 66 ± 15%

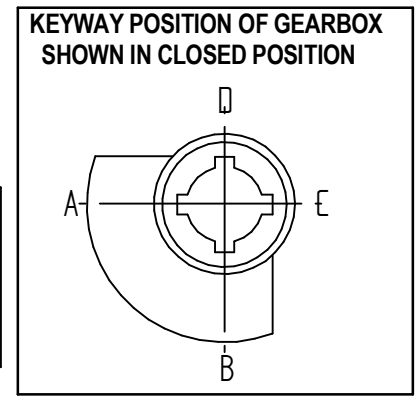

DIMENSIONS IN MM [INCH]

ROTORK GEARS

GEARBOX AB1950G-PR4 LB BU

DRAWN:- Robbin Goosen CHECKED:- Henk Hoff
 DWG:- AB1950G-PR4 LB BU REV: 01