

DESCRIPTION:

TRAVEL : -5° TO 95° adjustable
 RATIO : 217 : 1
 TURNS TO CLOSE : 54.34
 WEIGHT : 39 kg. (85 lb.) Excl. handwheel

MOUNTING HOLES :

BOLT CIRCLE : min. ϕ 125 [4.92]
 (OFF CENTER) : max. ϕ 254 [10.00]
 acc. ISO 5211 : F12 - F14 - F16 - F25
 Min. bore Quadrant : ϕ 30 [1.18]
 MAX. bore Quadrant : ∇ 60 [2.36] or ϕ 80 [3.15]

TORQUE :

max. OUTPUT : 7000 Nm (61955 lbf.in.)
 max. INPUT : 106 Nm (939 lbf.in.)
 MA : 66.0 \pm 15%

DIMENSIONS IN MM [INCH]

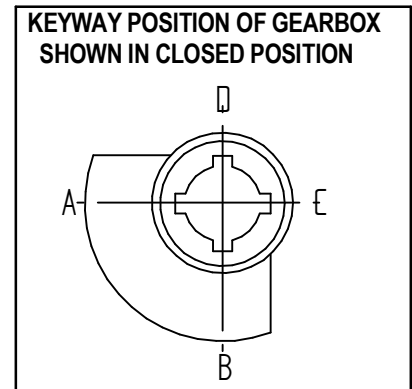

ROTORK GEARS

GEARBOX AB1950G-PR4

DRAWN:- Robbin Goosen CHECKED:- Henk Hoff
 DWG:- AB1950G-PR4 REV: 01