

DESCRIPTION:

TRAVEL : -5° TO 95° adjustable
 RATIO : 326 : 1
 TURNS TO CLOSE : 81.5
 WEIGHT : 63 kg. (138 lb.) Excl. handwheel

MOUNTING HOLES :

BOLT CIRCLE : min. ϕ 165 [6.50]
 (OFF CENTER) : max. ϕ 298 [11.73]
 acc. ISO 5211 : F16 - F25 - F30
 Min. bore Quadrant : ϕ 30 [1.18]
 MAX. bore Quadrant : \sphericalangle 75 [2.95] or ϕ 100 [3.94]

TORQUE :

max. OUTPUT : 12500 Nm (110634 lbf.in.)
 max. INPUT : 130 Nm (1152 lbf.in.)
 MA : 96.0 \pm 15%

DIMENSIONS IN MM [INCH]

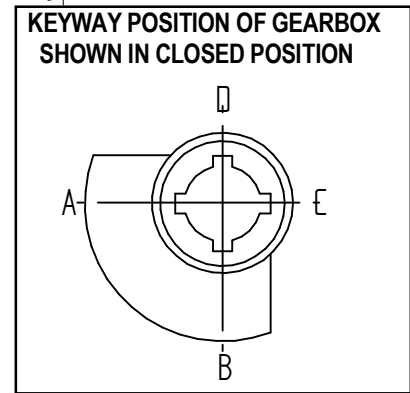

ROTORK GEARS

GEARBOX AB6800N-PR4

DRAWN:- Robbin Goosen CHECKED:- Henk Hoff

DWG:- AB6800N-PR4 REV: 01