

FLANGE TYPE acc. ISO 5211			
type	KEY	A	
F10	6x6 [0.24x0.24]	ø20[0.79]	
F14	8x7 [0.35x0.28]	ø30[1.18]	

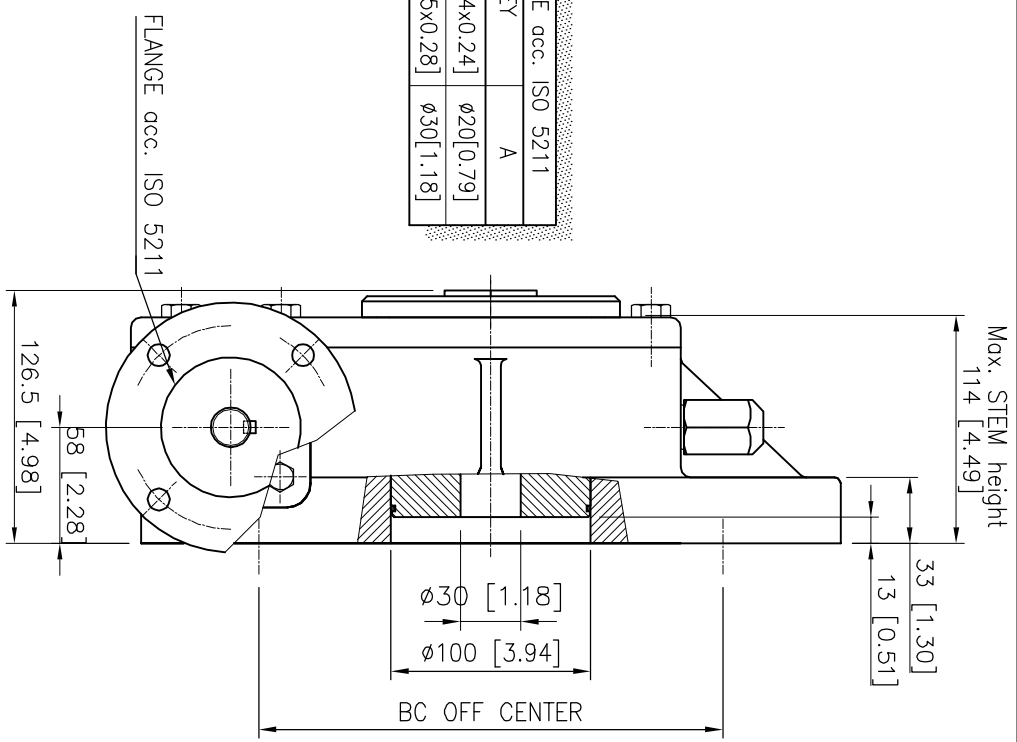

**DESCRIPTION**

TRAVEL : 90° ±5° AT BOTH ENDS.  
 RATIO : 52 : 1  
 TURNS TO CLOSE : 13  
 WEIGHT : 44.7kg.(98.5lb.) excl.handwheel

**MOUNTINGHOLES**

BOLT CIRCLE : min. ø125 [4.92]  
 (OFF CENTER) max. ø298 [11.73]  
 acc. ISO 5211 : F12-F14-F16-F25-F30  
 BORE : min.30[1.18] max.ø80[3.15] #60[2.36]

**TORQUE**

max.OUTPUT : 5500 Nm (48679 lbf.in.)  
 max.INPUT : 289 Nm (2562 lbf.in.)  
 M.A. : 19 ±15%

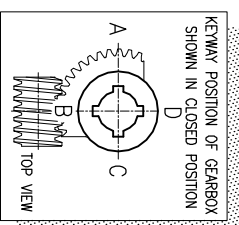

Dimensions in MM [inch]



Nijverheidstraat 25  
 7561 LA, Loosdrecht  
 The Netherlands

# GEARBOX E 1950G F10-F14 LB

THIS DOCUMENT IS PROPERTY OF ROTORK GEARS. NEITHER THIS OR ITS CONTENT MAY BE COPIED OR USED IN ANY OTHER WAY DETRIMENTAL TO THE INTEREST OF ROTORK GEARS. ACCEPTANCE OF THIS DOCUMENT SHALL CONSTITUTE ACKNOWLEDGEMENT OF THE FOREGOING CONDITIONS

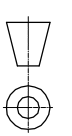

Drawn : N.M.  
 Dwg Nr.: D22GLB-001

Date : 08-12-08  
 Rev.: 01