

CIRCUIT IS DRAWN FOR A VALVE IN THE MID-TRAVEL

ACTUATOR SHOWN IN MID-TRAVEL

TYPICAL CONTROL - NOT ROTORK SUPPLY

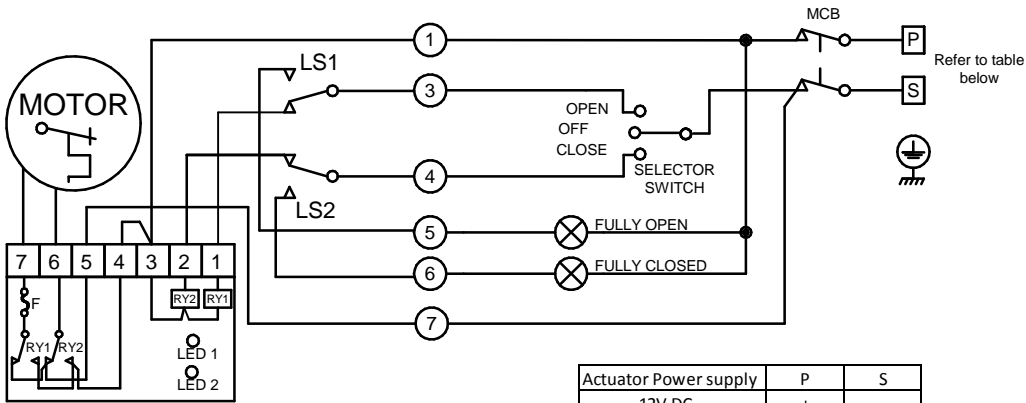

12/24V AC/DC SUPPLY

Actuator Power supply	P	S
12V DC	+	-
24V DC	+	-
12V AC	N	L
24V AC	N	L

- O - OPEN
- C - CLOSE
- TS - TORQUE SWITCHES
- LS - LIMIT SWITCHES
- MCB - MINITURE CIRCUIT BREAKER
- ACTUATOR TERMINAL

**CAUTION**  
SOLID STATE LOGIC SYSTEMS USING ACTUATOR SWITCH SIGNAL INPUTS MUST BE DESIGNED TO PROVIDE A SWITCHING LOAD OF 1 WATT & 24V MINIMUM WITH A TIME CONSTANT NOT LESS THAN 10ms TO MINIMISE SENSITIVITY TO CONTACT VIBRATION.

ACTUATOR SHOWN IN MID-TRAVEL

TYPICAL CONTROL - NOT ROTORK SUPPLY

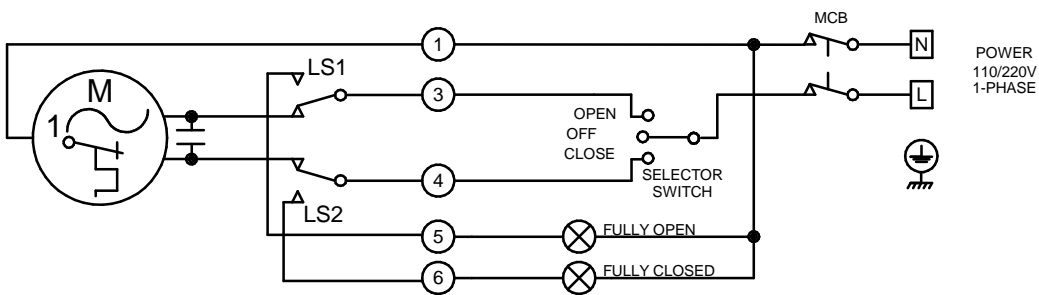

SINGLE PHASE SUPPLY

POWER  
110/220V  
1-PHASE

ACTUATOR SHOWN IN MID-TRAVEL

TYPICAL CONTROL - NOT ROTORK SUPPLY

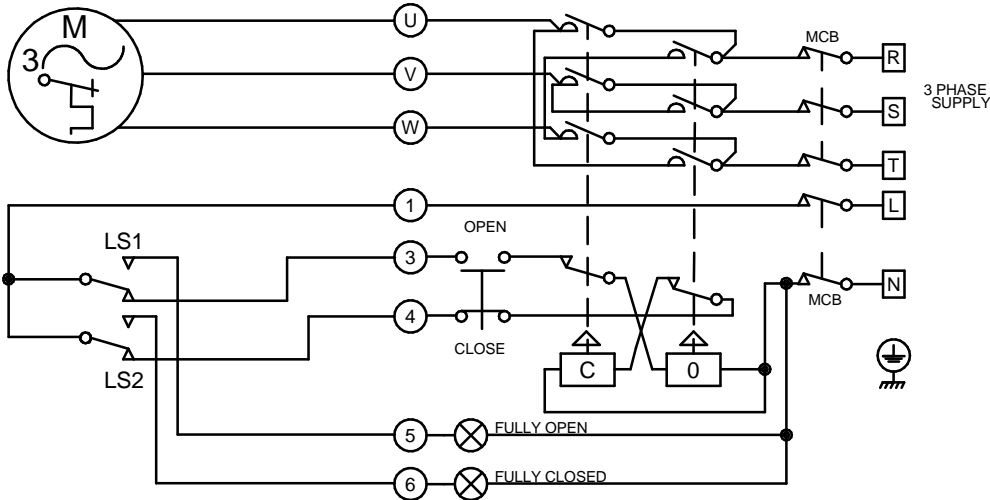

THREE PHASE SUPPLY

DO NOT RUN ACTUATOR TO LIMITS WITH INCORRECT PHASE ROTATION.

WHERE DISTANCES ARE GREAT BETWEEN ACTUATOR AND CONTROL GEAR, CABLE CAPACITANCE MAY CAUSE CONTACTORS TO STICK ON A.C. CIRCUITS

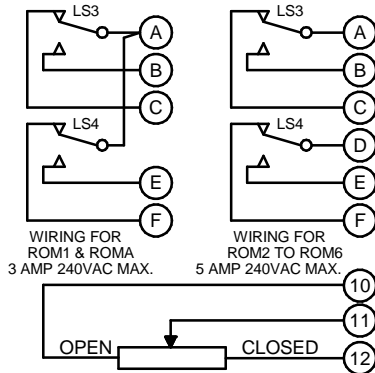

WIRING FOR ROM1 & ROMA  
3 AMP 240VAC MAX.

WIRING FOR ROM2 TO ROM6  
5 AMP 240VAC MAX.

Iss	Date	Chkd	Revision Details
6	11/21/17 Kelly	JJ	Correct the description that CIRCUIT IS DRAWN FOR A VALVE IN THE FULLY POSITION

[www.rotork.com](http://www.rotork.com)

ROTORK CONTROLS LTD  
BATH, BA1 3JQ  
ENGLAND  
Tel:01225-733200

ROTORK CONTROLS INC  
ROCHESTER  
NY 14624, USA  
Tel:585-247-2304

BASIC + LS3/LS4 + POT -

Drawn by: PJW  
Date : 170402  
Base WD: --  
Job No : --  
MI No : --

Circuit Diagram No  
**YS03-00**  
Issue No  
**6**