

G
F
E
D
C
B
A

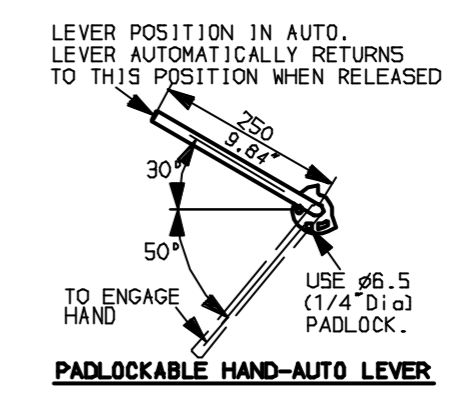

NOTES:
 : DIMENSIONS WITH '*' INDICATE COVER REMOVAL ALLOWANCE
 : NETT WEIGHT = 1010kg (2222lbs)
 : = OIL FILLER/DRAIN PLUG
 : THE INTERFACE PROVIDED FOR MOUNTING THE ACTUATOR OR SECOND STAGE GEARBOX ONTO THE VALVE SHOULD CONFORM TO GOOD ENGINEERING PRACTICES, ENSURING ADEQUATELY TOLERANCED LIMITS FOR PARALLELISM, PERPENDICULARITY AND CONCENTRICITY.

CONDUIT ENTRIES (N.T.S)

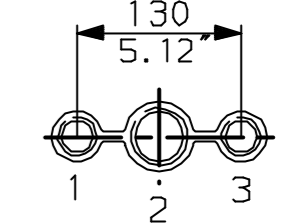

Nos.1 & 3 TAPPED 1" NPT
 No.2 TAPPED 1 1/2" NPT
 STD ALTERNATIVES IF SPECIFIED
 2 X M25, 1 X M40
 2 X PG16, 1 X PG29

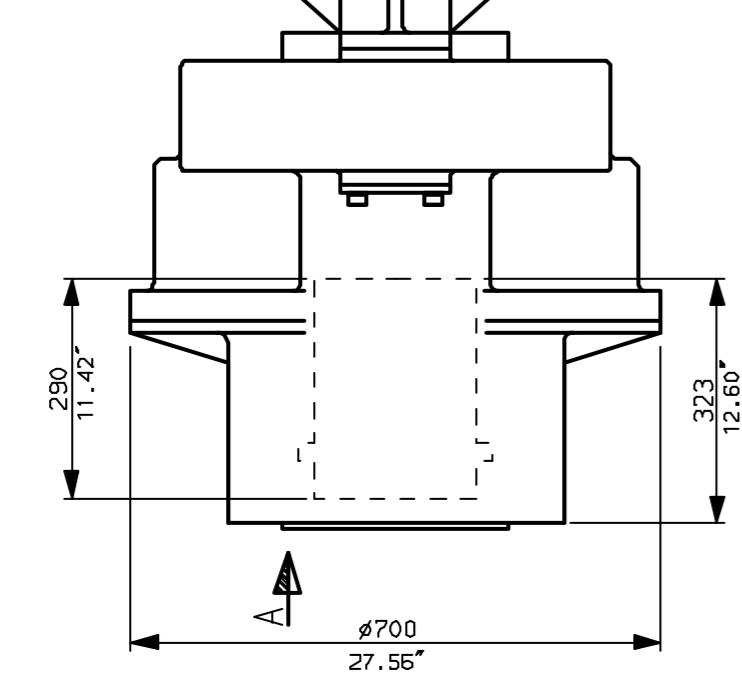
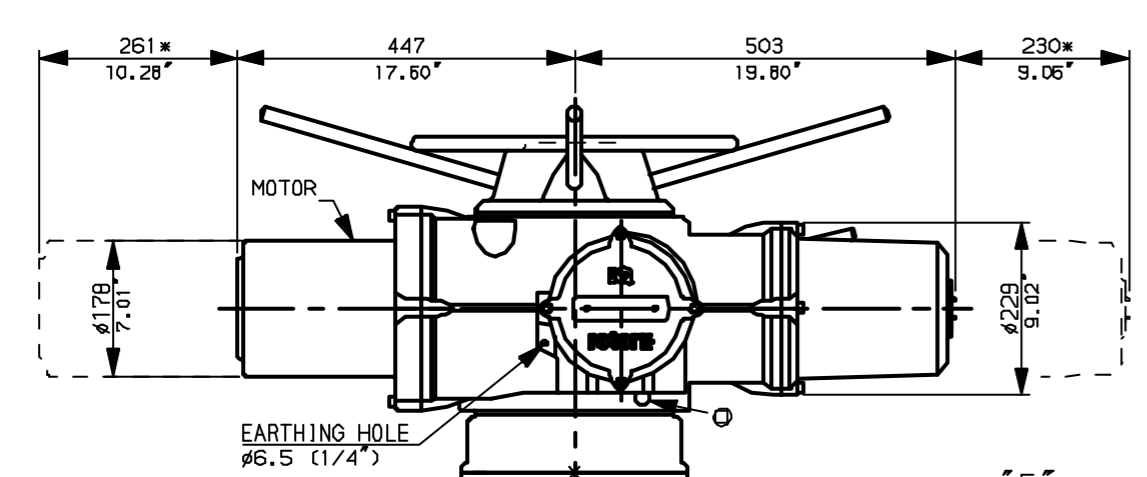
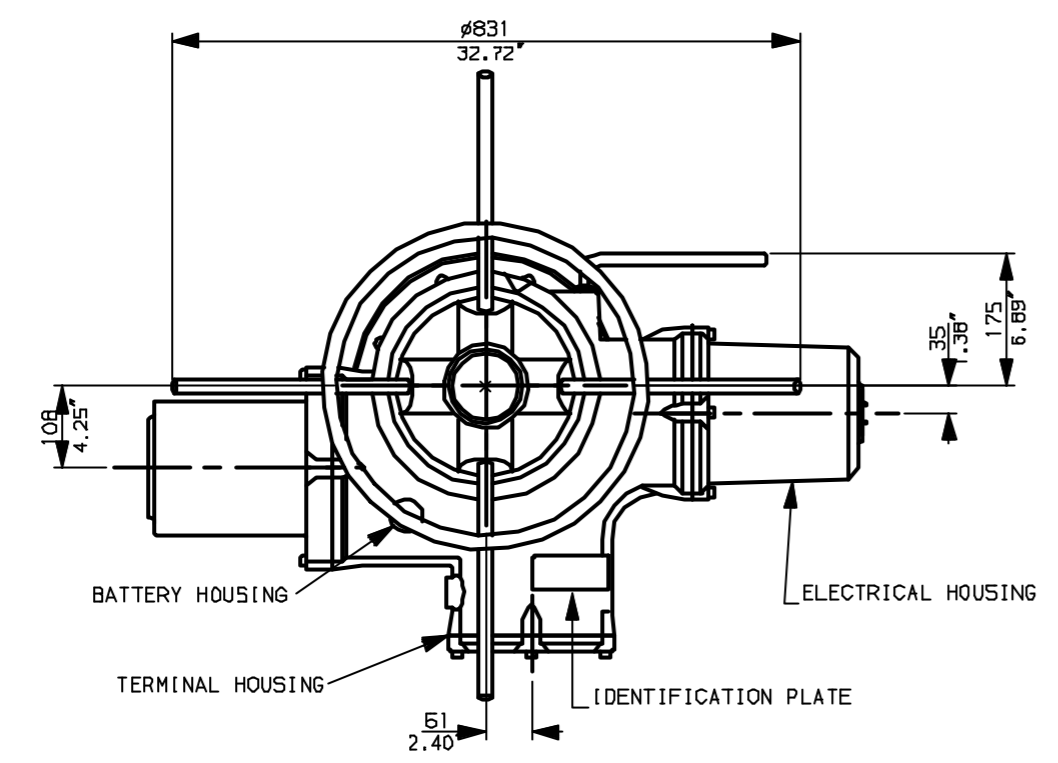

"F" version
 8 HOLES TAPPED M36x45 DP
 EQUI-SPACED AS SHOWN
 ON A 406 PCD.
 (ISO 5210-F40)
 "FA" version
 8 HOLES TAPPED 1.25"UNCx1.8" dp
 EQUI-SPACED AS SHOWN
 ON A 16" PCD.
 (MSS SP102-FA40)

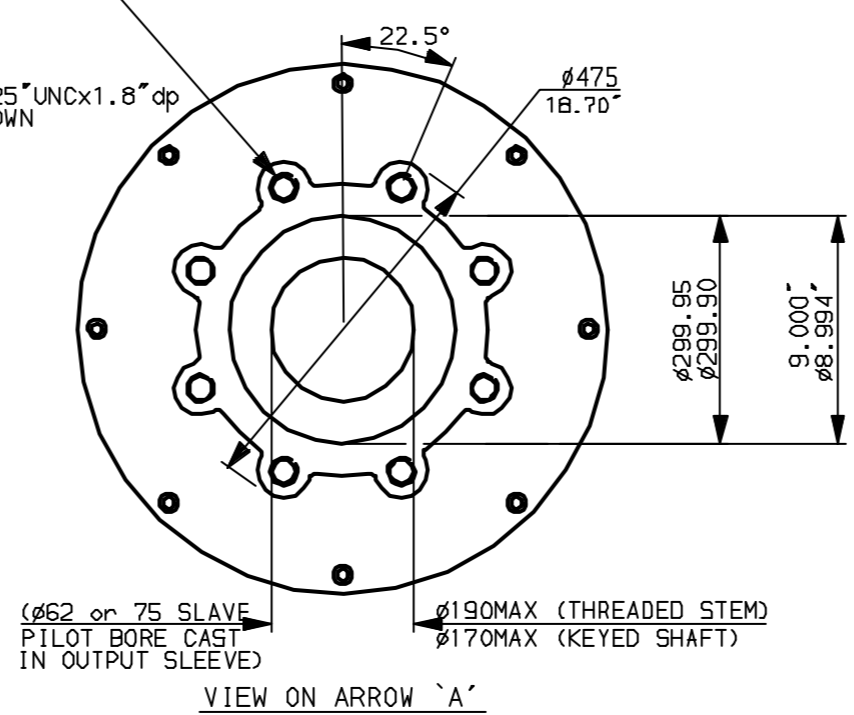

(#62 or 75 SLAVE PILOT BORE CAST IN OUTPUT SLEEVE)
 #190MAX (THREADED STEM)
 #170MAX (KEYED SHAFT)
 VIEW ON ARROW 'A'

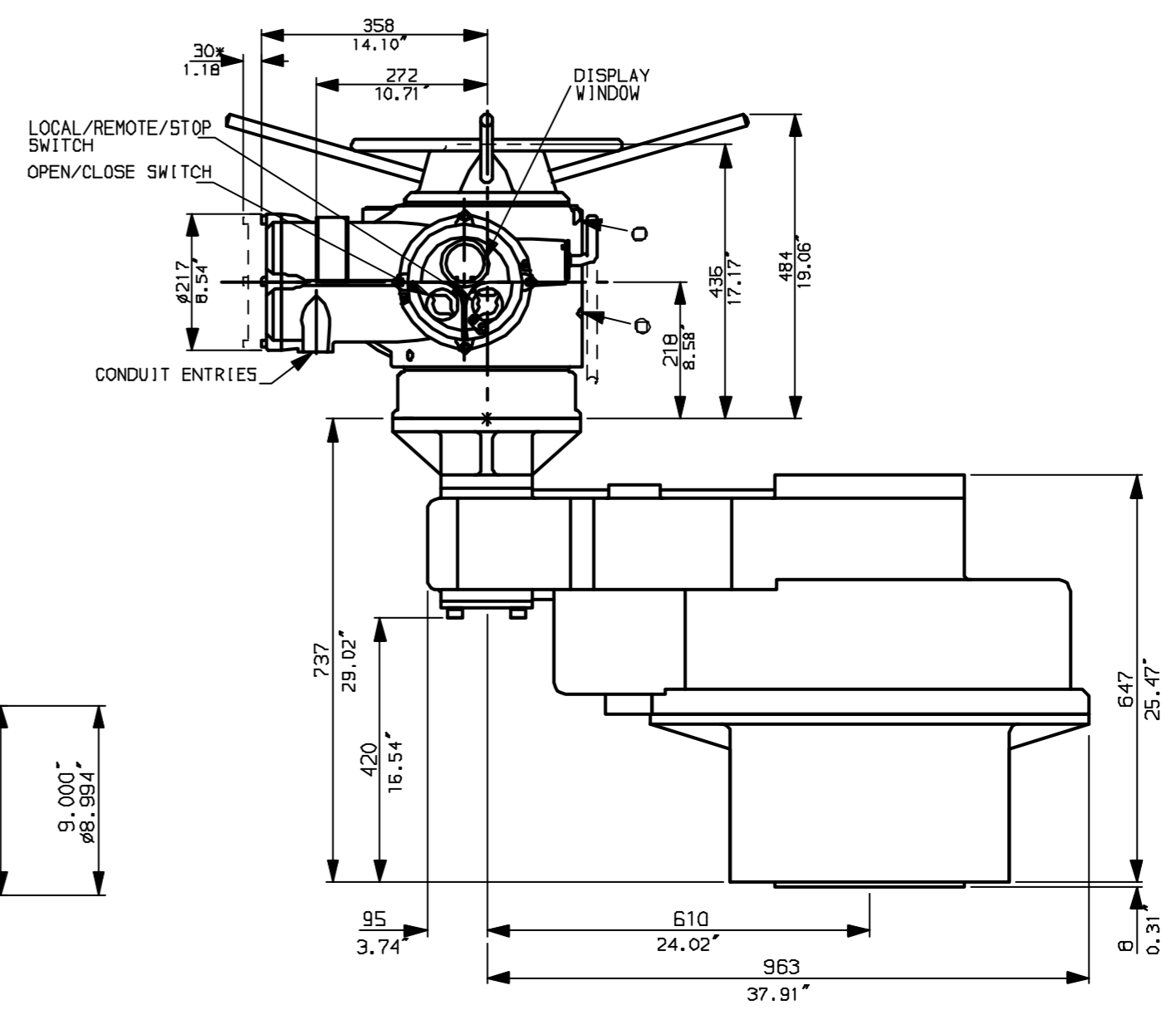

Rotork Controls Ltd.
 Bath England, BA1 3JQ.
 (Phone 01225-733200)
 Rotork Controls Inc.
 Rochester, NY 14624
 (Phone 585-328-1550)

Title IQ40, THW, IS19,		
STANDARD DIMENSIONAL DATA		
Drawn Cad	Checked PRE	Ref Data Sheet
Date April 04	Job No	IQ40THW_IS19

01	First Issue.
Scale	1:10 THIRD ANGLE PROJECTION
Drawing Number	IQ40THW_IS19

1 | 2 | 3 | 4 | 5 | 6 | 7 | 8 | 9 | 10

G
F
E
D
C
B
A

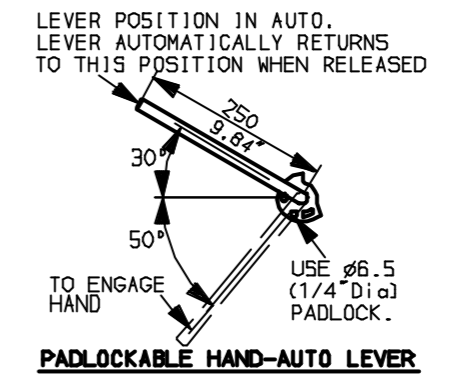
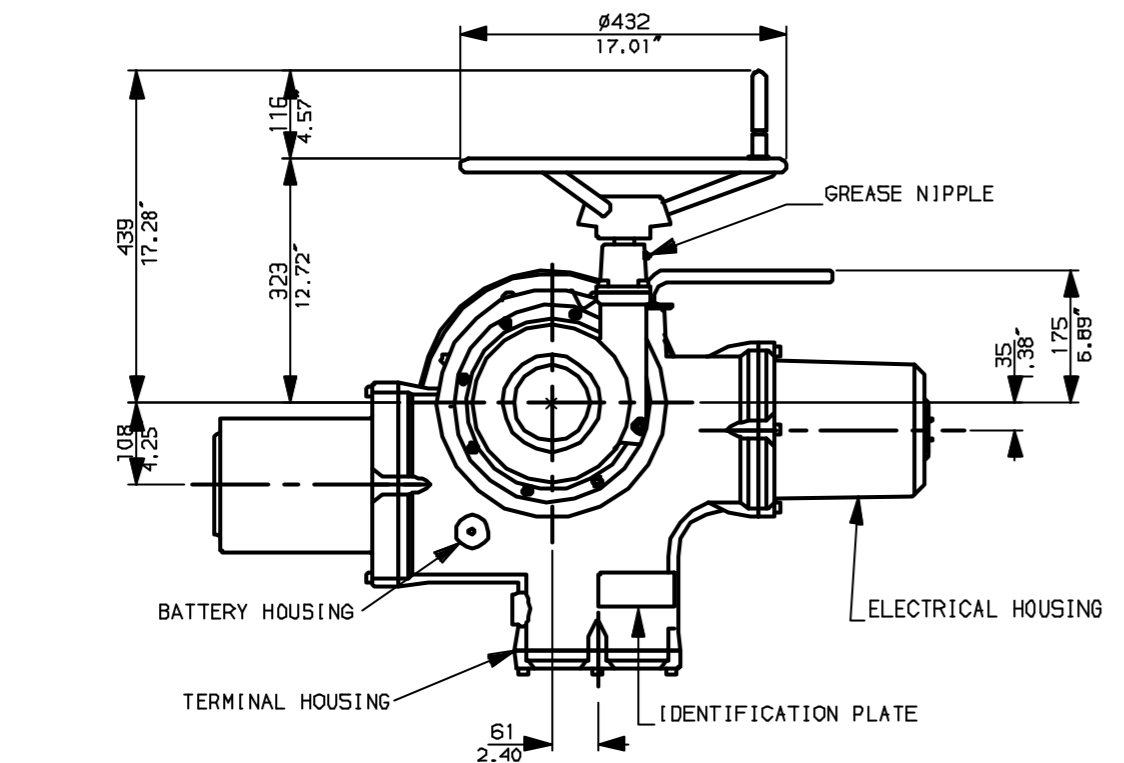

NOTES:

- DIMENSIONS WITH '*' INDICATE COVER REMOVAL ALLOWANCE
- NETT WEIGHT = 1010kg (2222lbs)
- \odot = OIL FILLER/DRAIN PLUG
- THE INTERFACE PROVIDED FOR MOUNTING THE ACTUATOR OR SECOND STAGE GEARBOX ONTO THE VALVE SHOULD CONFORM TO GOOD ENGINEERING PRACTICES, ENSURING ADEQUATELY TOLERANCED LIMITS FOR PARALLELISM, PERPENDICULARITY AND CONCENTRICITY.

CONDUIT ENTRIES (N.T.S)

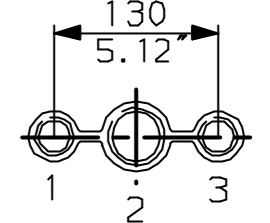

Nos.1 & 3 TAPPED 1" NPT
 No.2 TAPPED 1 1/2" NPT
 STD ALTERNATIVES IF SPECIFIED
 2 X M25, 1 X M40
 2 X PG16, 1 X PG29

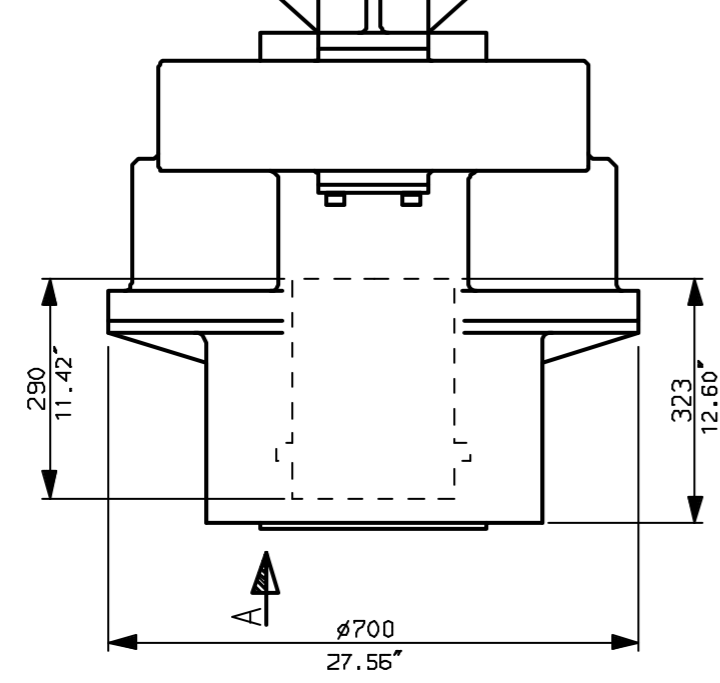
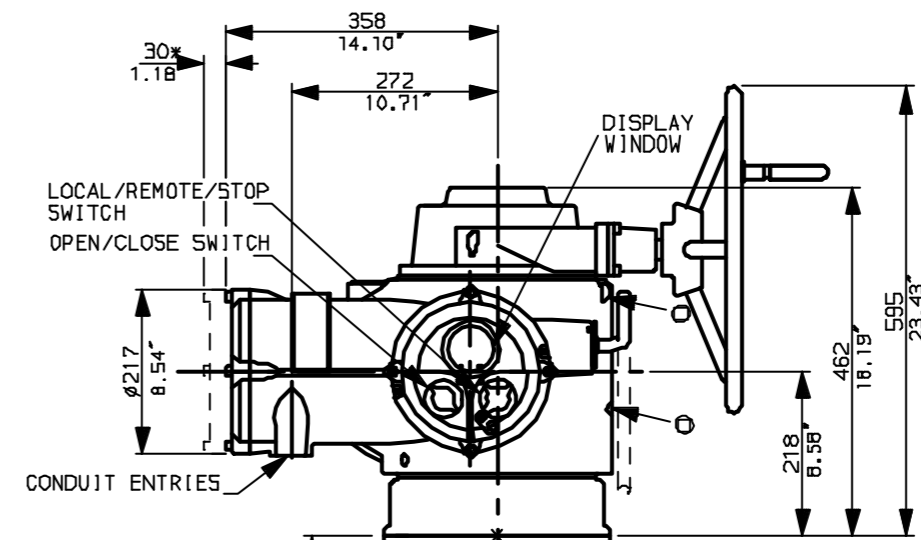
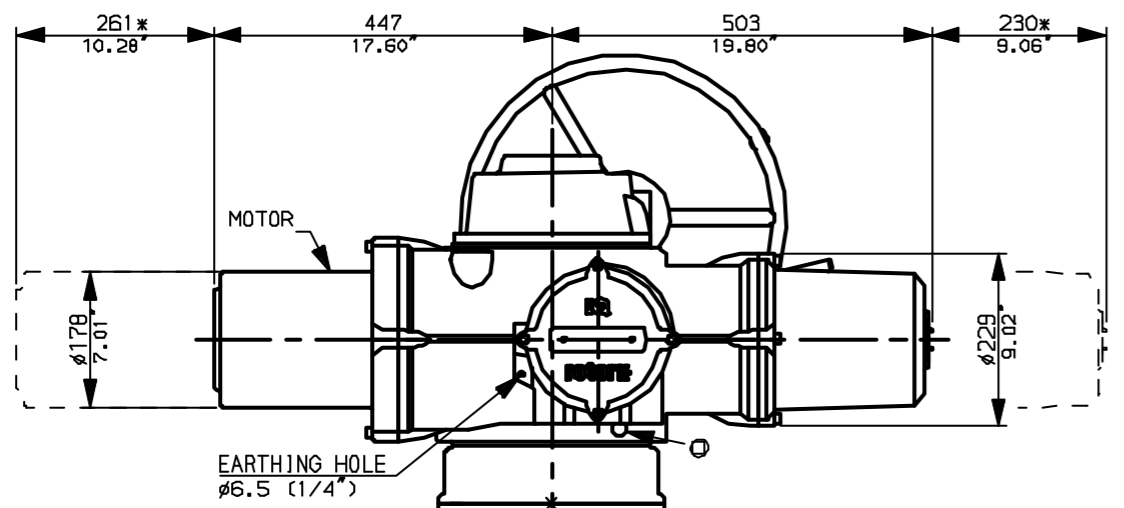

"F" version
 8 HOLES TAPPED M36x45 DP
 EQUI-SPACED AS SHOWN
 ON A 406 PCD.
 (ISO 5210-F40)

"FA" version
 8 HOLES TAPPED 1.25"UNCx1.8"dp
 EQUI-SPACED AS SHOWN
 ON A 16" PCD.
 (MS SP102-FA40)

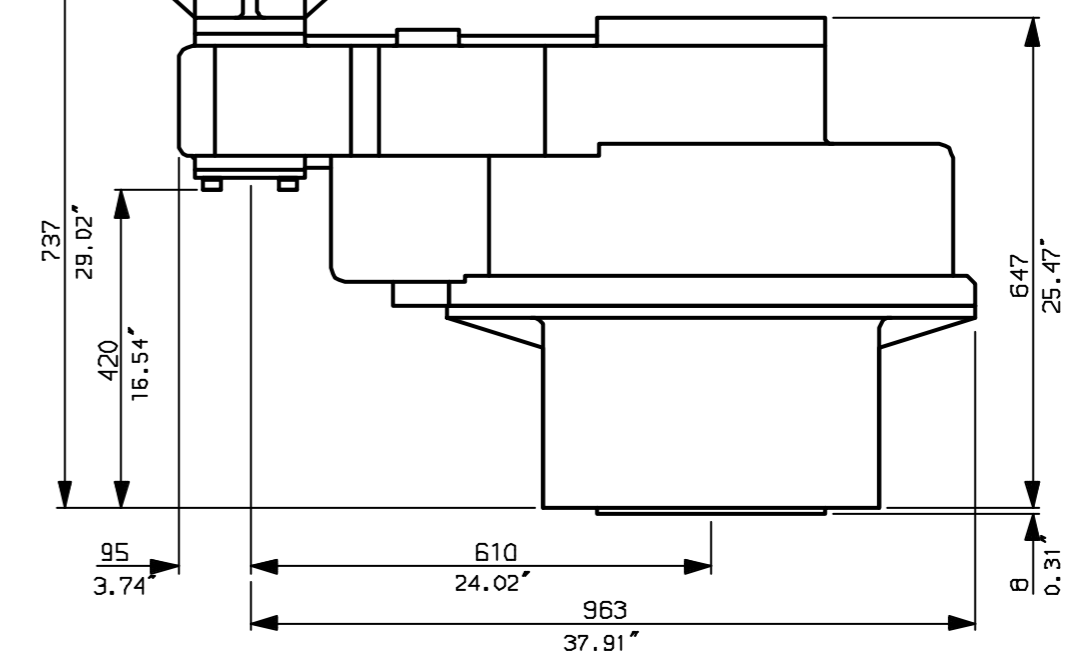
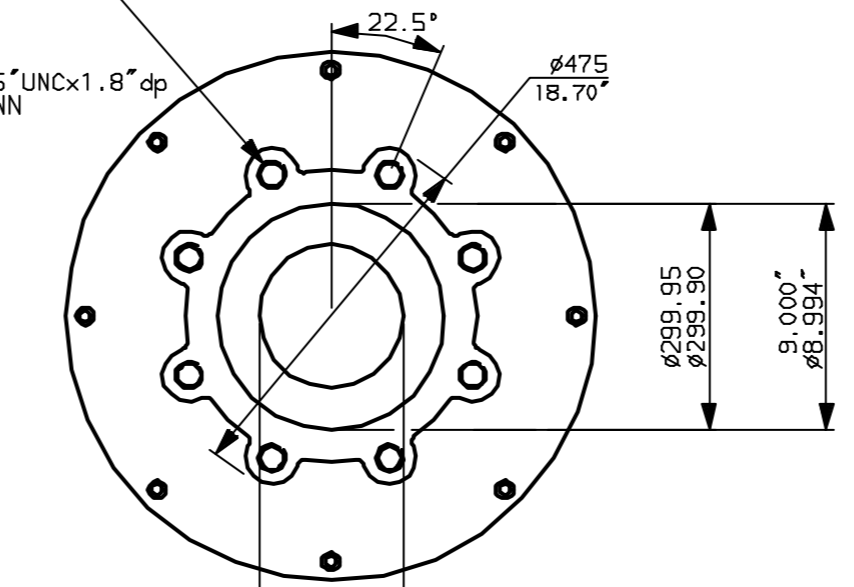

Rotork Controls Ltd.
 Bath England, BA1 3JQ.
 (Phone 01225-733200)

Rotork Controls Inc.
 Rochester, NY 14624
 (Phone 585-328-1550)

Title IQ40, SHW, IS19,		
STANDARD DIMENSIONAL DATA		
Drawn Cad	Checked PRE	Ref Data Sheet
Date April 04	Job No	IQ40SHW_IS19

01	First Issue.
Scale	1:10 THIRD ANGLE PROJECTION
Drawing Number	IQ40SHW_IS19

1 | 2 | 3 | 4 | 5 | 6 | 7 | 8 | 9 | 10

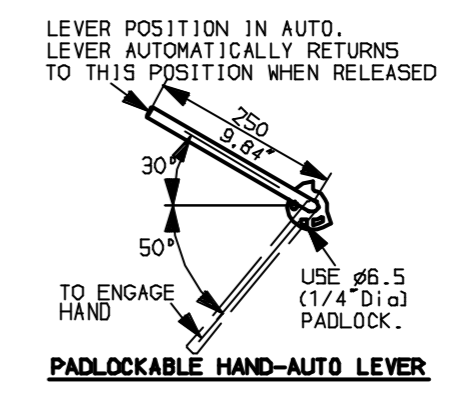
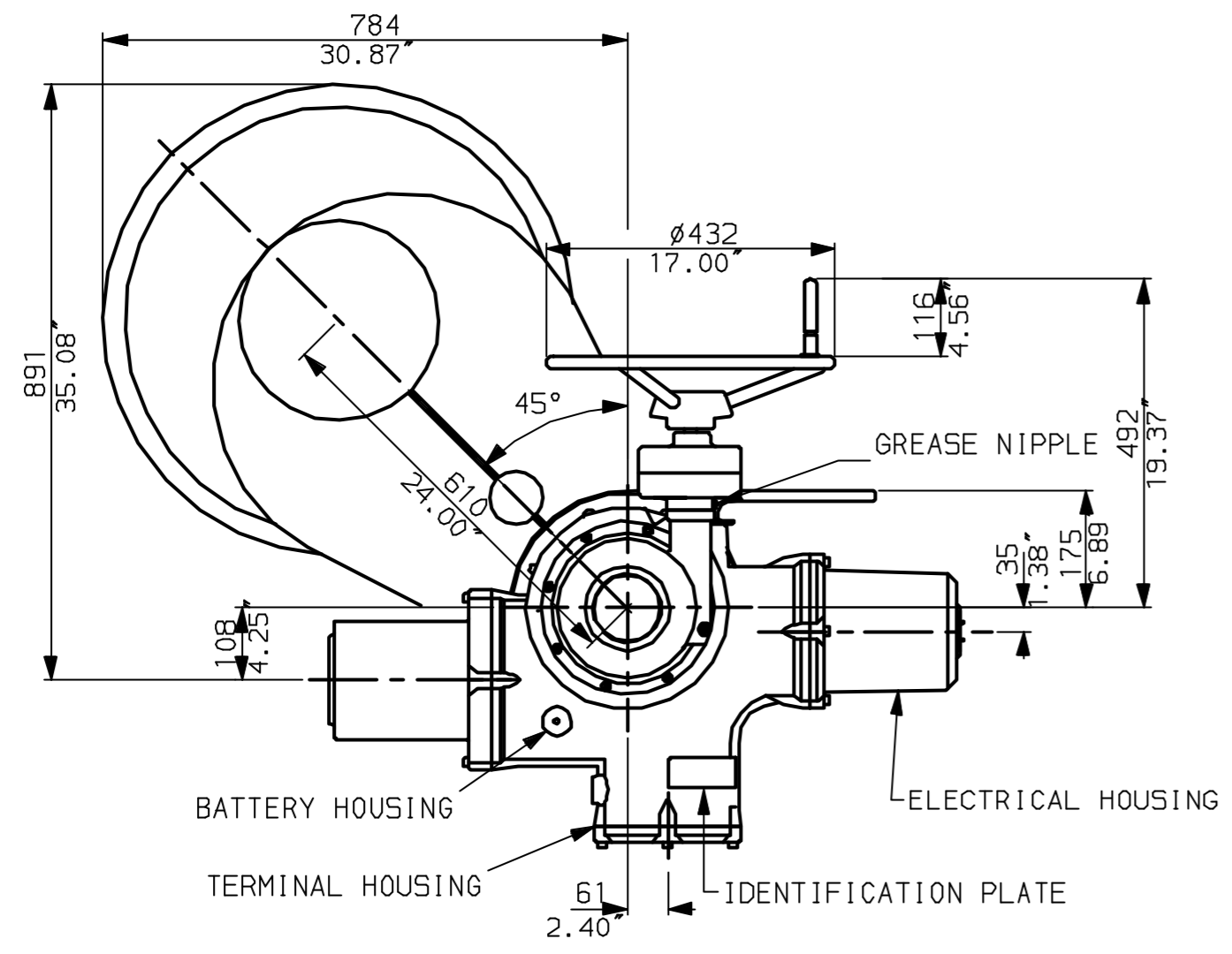

NOTES:
 * DIMENSIONS WITH '*' INDICATE COVER REMOVAL ALLOWANCE
 : NETT WEIGHT = 1010kg (2222lbs)
 : = OIL FILLER/DRAIN PLUG
 : THE INTERFACE PROVIDED FOR MOUNTING THE ACTUATOR OR SECOND STAGE GEARBOX ONTO THE VALVE SHOULD CONFORM TO GOOD ENGINEERING PRACTICES, ENSURING ADEQUATELY TOLERANCED LIMITS FOR PARALLELISM, PERPENDICULARITY AND CONCENTRICITY.

CONDUIT ENTRIES (N.T.S)

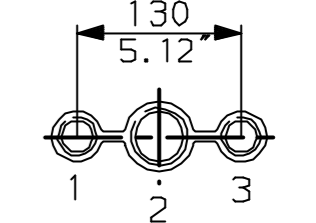

Nos.1 & 3 TAPPED 1" NPT
 No.2 TAPPED 1 1/2" NPT
 STD ALTERNATIVES IF SPECIFIED
 2 X M25, 1 X M40
 2 X PG16, 1 X PG29

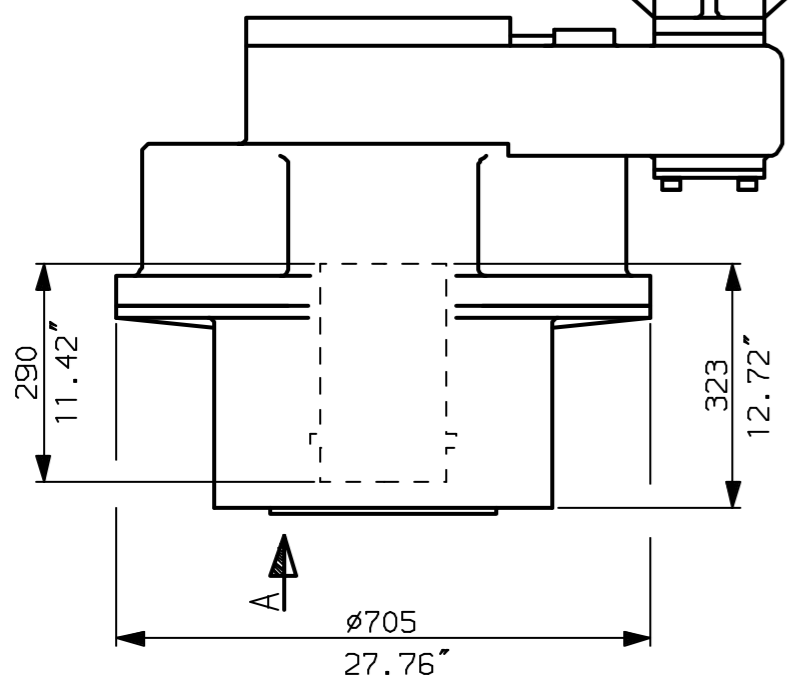
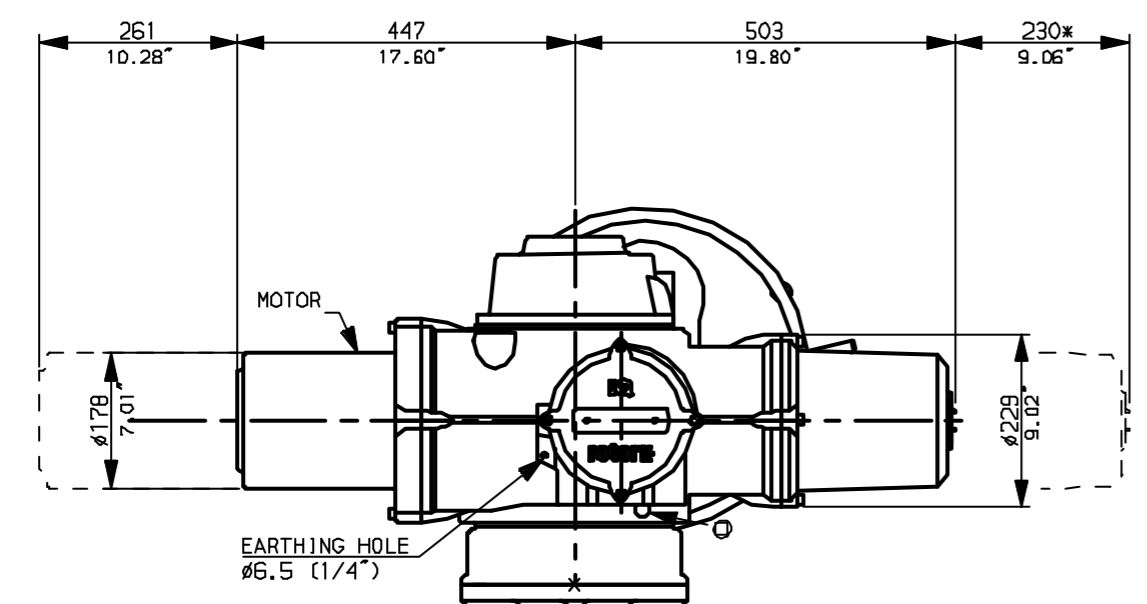

"F" version

8 HOLES TAPPED M36x45 DP
 EQUI-SPACED AS SHOWN
 ON A 406 PCD.
 (ISO 5210-F40)

"FA" version

8 HOLES TAPPED 1.25"UNCx1.8"dp
 EQUI-SPACED AS SHOWN
 ON A 16" PCD.
 (MSS SP102-FA40)

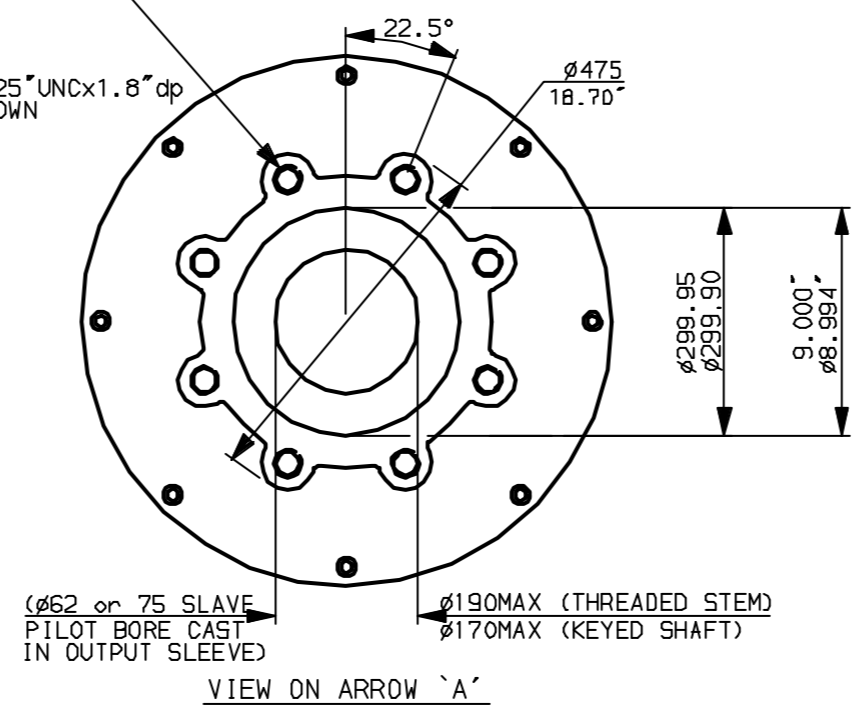

Ø62 or 75 SLAVE PILOT BORE CAST IN OUTPUT SLEEVE
 Ø190MAX (THREADED STEM)
 Ø170MAX (KEYED SHAFT)

VIEW ON ARROW 'A'

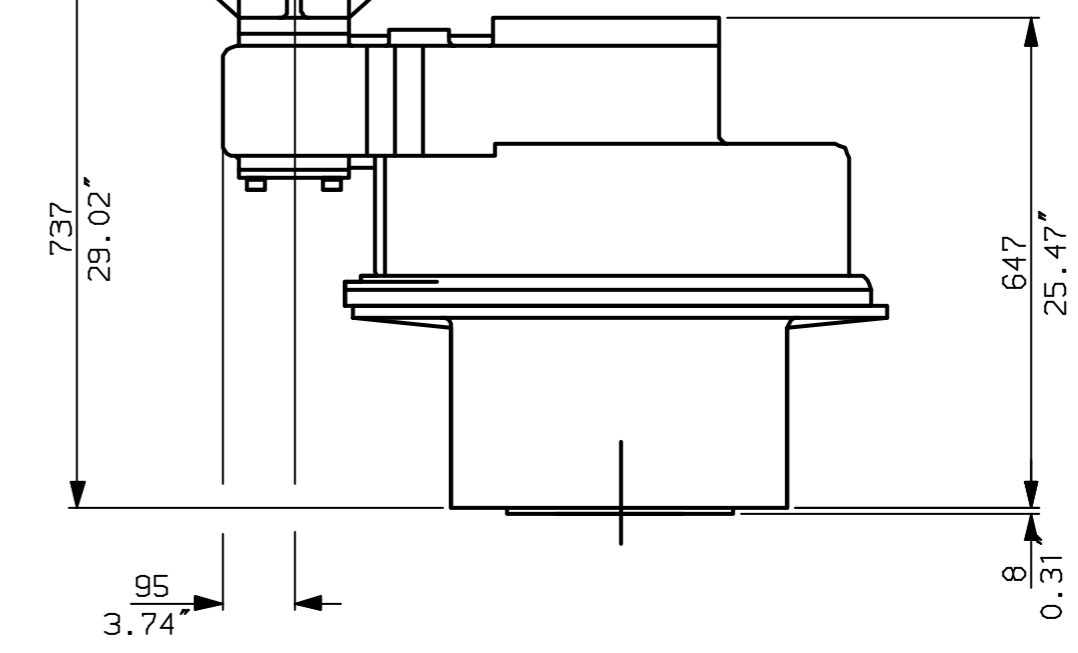
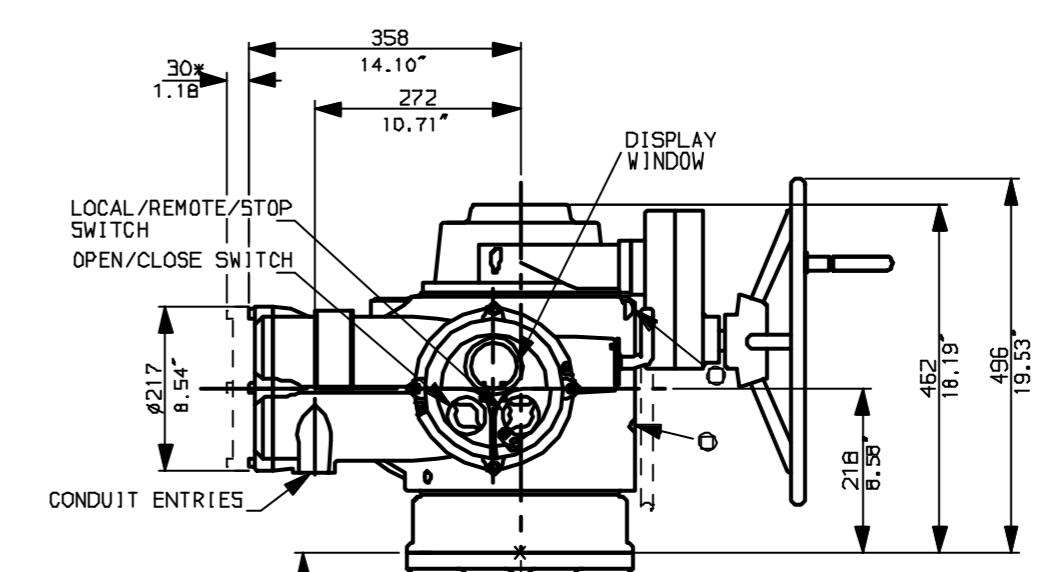

Rotork Controls Ltd.
 Bath England, BA1 3JQ.
 (Phone 01225-733200)
 Rotork Controls Inc.
 Rochester, NY 14624
 (Phone 585-328-1550)

Title IQ40, SSHW, IS19,		
STANDARD DIMENSIONAL DATA		
Drawn Cad	Checked PRE	Ref Data Sheet
Date April 04	Job No	IQ40SSHW_IS19

01	First Issue.
Scale	1:10 THIRD ANGLE PROJECTION
Drawing Number	IQ40SSHW_IS19