

CIRCUIT DRAWN WITH POWER SUPPLY OFF

FOR TYPICAL REMOTE CONTROL  
DETAILS, SEE DOCUMENT  
**RWS100**

TRANSFORMER TAPPING OPTIONS	
Tap	Nominal 50/60Hz
TYPE 1	
W	220/230
X	380/400
Y	400,415/420
Z	440/460
FUSE FS 1=250mA ANTI-SURGE	
TYPE 2	
W	346/380
X	480/500
Y	240/240
Z	550/575
FUSE FS 1=250mA ANTI-SURGE	

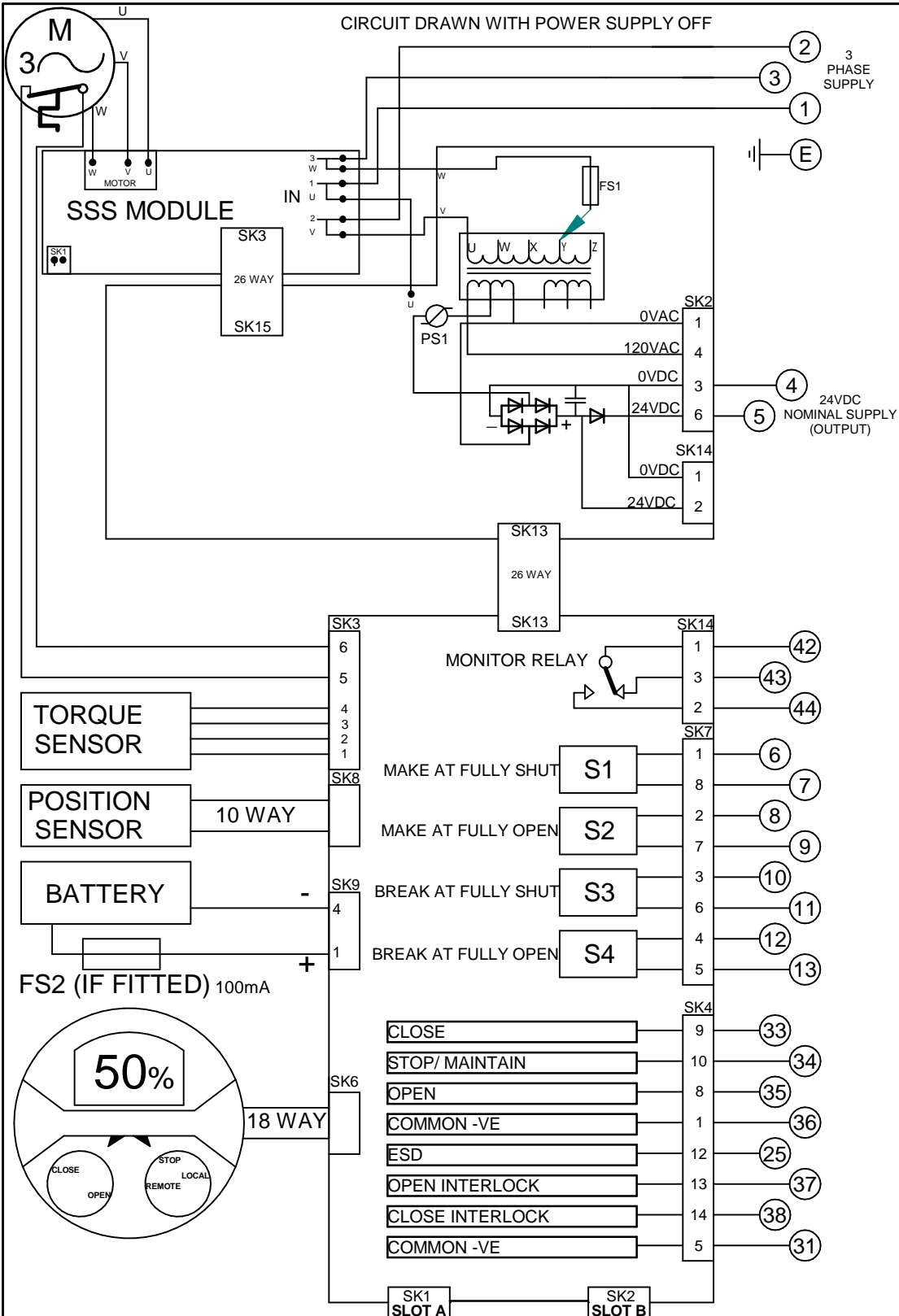

REFER TO SHEET 2 FOR NOTES  
& OPTION PCB'S IF FITTED

THE ACTUATOR MUST BE  
PROTECTED USING SUITABLY  
RATED HIGH SPEED  
SEMI-CONDUCTOR FUSES ON THE  
INCOMING SUPPLY.

SUGGESTED FUSES :-  
IQ10-20:10 Amp FERRAZ G330010  
IQ25-35:20 Amp FERRAZ K330013  
ALTERNATIVES =  
IQ10-20:10 Amp SIBA 50-179-06/10A  
IQ25-35:20 Amp SIBA 50-179-06/20A  
OR EQUIVALENT PROTECTIVE  
DEVICE.

Iss	Date	Chkd	Revision Details
1	111013	PJW	First Issue.
2	230614	MR	400v added to type 1 tapping Y. Note added to sheet 2 note 1.
3	130616	PW	Updated notes on page 2.

**www.rotork.com**

ROTORK CONTROLS LTD BATH, BA1 3JQ ENGLAND Tel:01225-733200	ROTORK CONTROLS INC ROCHESTER NY 14624, USA Tel:585-247-2304
---	---

IQM + EXT PWR CPT

Drawn by: JC1 Date : 111013 Base WD: 205B0000 Job No : -- MI No : --	Circuit Diagram Number <b>205B0000</b>	Issue No <b>3</b>	Sheet <b>1</b> of 2
--	---	----------------------	---------------------------

# SLOT A

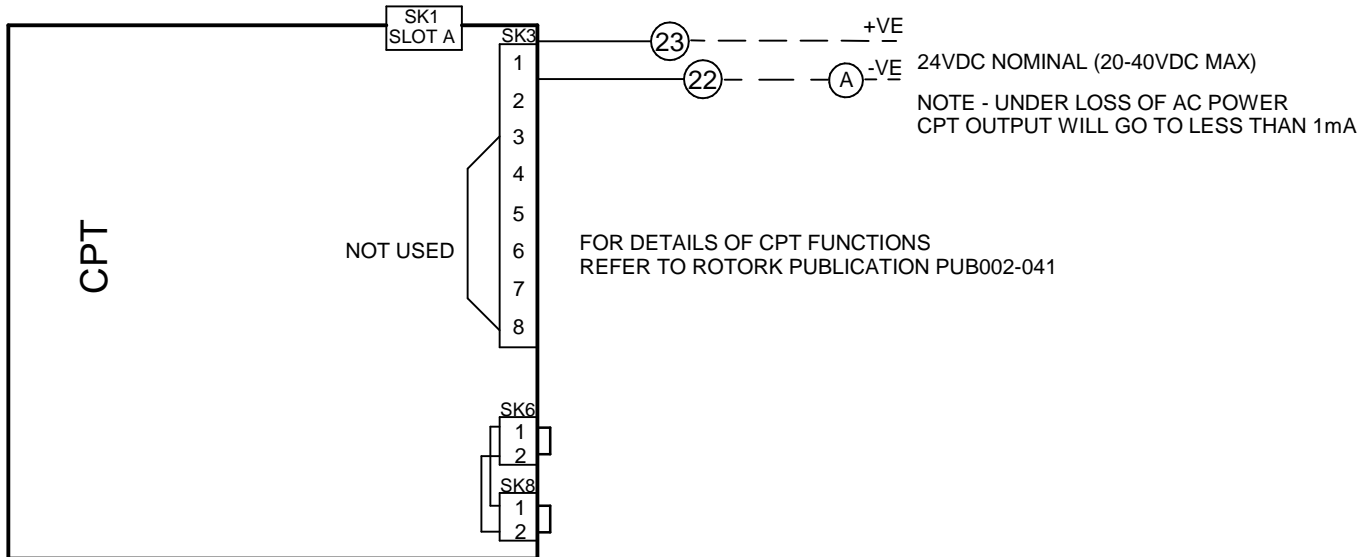

## NOTES

### 1.FUSES:

- PS1 is a self-resetting fuse.
- Refer to publication PUB002-039 for approved fuses FS1 and FS2.
- Actuator rated voltage specified on nameplate. Voltage tolerance +/-10%, applies for rated torque performance; duty cycle is not guaranteed.

### 2.REMOTE CONTROL:

- For typical remote control circuits refer to:
  - RWS indicated or PUB002-041.
- For DC and AC control, connect -ve/0V to terminal 36.
- (For negative switch / positive common, refer to RWS indicated).
- Control signal threshold voltages:
  - DC: "on"  $\geq 16Vdc$  / "off"  $\leq 8Vdc$ , max 60Vdc.
- Control signal duration to be 100ms minimum.
- Maximum current drawn from remote control signals is:
  - 8mA at 24Vdc .
- Supply provided on terminals 4 & 5:
  - Intended for remote control.
  - Max external load 5W at 24Vdc

### 3.INDICATION:

- For typical position, status and alarm indication see PUB002-041.
- “S” contacts are user configurable and are shown in their default setting.
- Refer to PUB002-040 for functions and configuration instructions.
- Monitor Relay indicates actuator availability for remote control (shown “unavailable”). It can be configured to exclude local/remote selection.
- Refer to PUB002-040 for monitored functions and configuration instructions.
- Voltage applied to indication contacts must not exceed 150Vac
- Individual Switch current must not exceed 3.5A inductive, 5A resistive and no more than 8A in total for all 4 contacts.

### 4.BATTERY:

- Battery maintains local and remote “S” contact indication only.
- Refer to installation manual for approved replacement battery types.

See Sheet 1 for all Revision details/information

Circuit Diagram Number	Issue No	Sheet
205B0000	3	2 of 2