

FOR TYPICAL REMOTE CONTROL DETAILS, SEE DOCUMENT **RWS100**

REFER TO SHEET 2 FOR NOTES & OPTION PCB'S IF FITTED

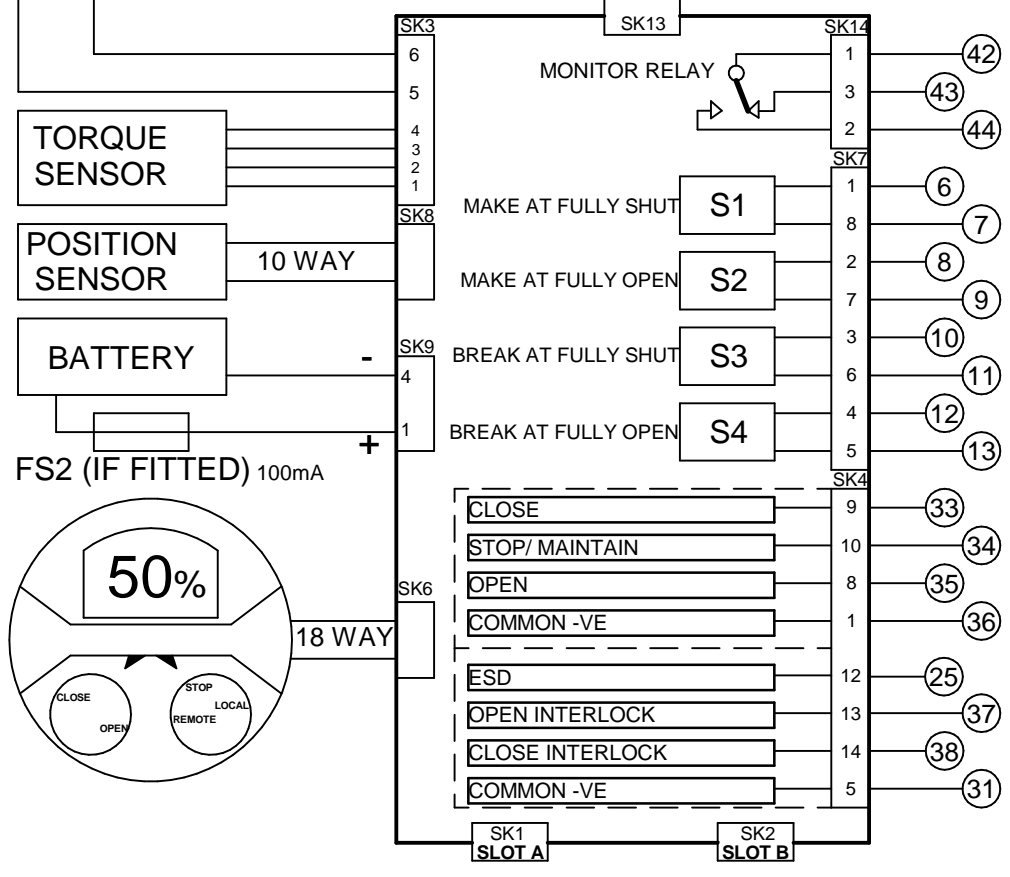

Iss	Date	Chkd	Revision Details
1	061113	JC1	First Issue.
2	160614	MR	Sheet 2, Note 1 updated.
3	270116	TH	Updated modbus note

www.rotork.com

ROTORK CONTROLS LTD
BATH, BA1 3JQ
ENGLAND
Tel:01225-733200

ROTORK CONTROLS INC
ROCHESTER
NY 14624, USA
Tel:585-247-2304

IQ SINGLE PHASE + SINGLE CHANNEL MODBUS MODULE AUX POWERED.

Drawn by: PJW
Date : 061113
Base WD: 120M5000
Job No : --
MI No : --

Circuit Diagram Number		Issue No	Sheet
120M5000		3	1
B1	C1	B2	C2

of 2

SLOT A

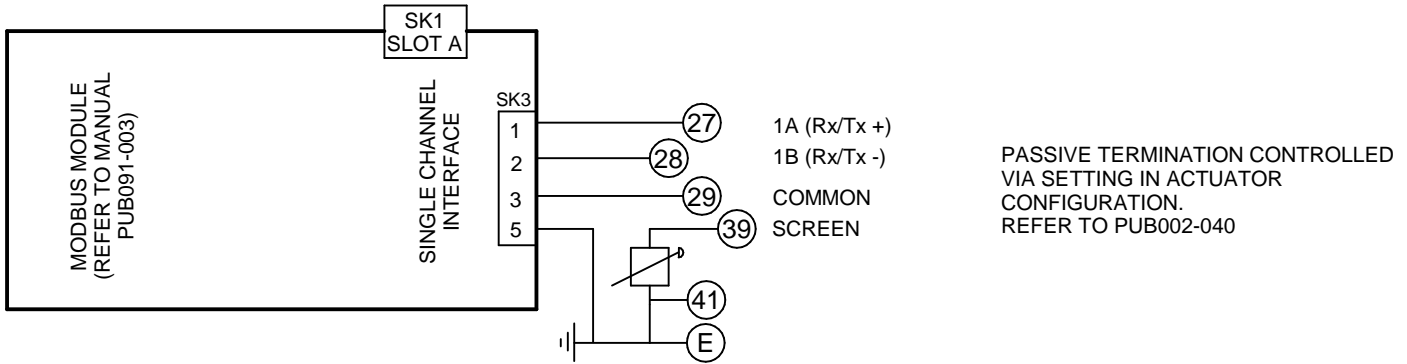

MODBUS RS485 SIGNAL LINES REQUIRE EXTERNAL ACTIVE BIASING TO BE PROVIDED AT ONE LOCATION FOR THE WHOLE BUS SEGMENT. REFER TO PUB091-004.

SLOT B

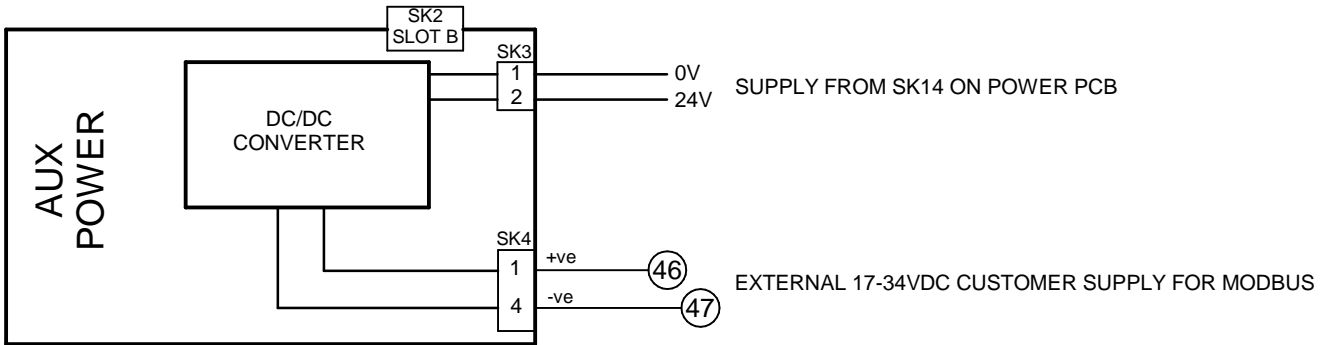

NOTES

1.FUSES:

- PS1 is a self-resetting fuse.
- Refer to publication PUB002-039 for approved fuses FS1 and FS2.
- Actuator rated voltage specified on nameplate. Voltage tolerance +/-10%, applies for rated torque performance; duty cycle is not guaranteed.

2.REMOTE CONTROL:

- For typical remote control circuits refer to:
 - RWS indicated or PUB002-041.
- For DC and AC control, connect -ve/0V to terminal 36.
- (For negative switch / positive common, refer to RWS indicated).
- Control signal threshold voltages:
 - DC: "on" $\geq 16Vdc$ / "off" $\leq 8Vdc$, max 60Vdc.
 - AC: "on" $\geq 60Vac$ / "off" $\leq 40Vac$, max 120Vac.
- Control signal duration to be 300ms minimum.
- Maximum current drawn from remote control signals is:
 - 8mA at 24Vdc or 12mA at 120Vac.
- Supply provided on terminals 4 & 5:
 - Intended for remote control.
 - Max external load 5W at 24Vdc / 5VA at 120Vac

3.INDICATION:

- For typical position, status and alarm indication see PUB002-041.
- “S” contacts are user configurable and are shown in their default setting.
- Refer to PUB002-040 for functions and configuration instructions.
- Monitor Relay indicates actuator availability for remote control (shown “unavailable”). It can be configured to exclude local/remote selection.
- Refer to PUB002-040 for monitored functions and configuration instructions.
- Voltage applied to indication contacts must not exceed 150Vac
- Individual Switch current must not exceed 3.5A inductive, 5A resistive and no more than 8A in total for all 4 contacts.

4.BATTERY:

- Battery maintains local and remote “S” contact indication only.
- Refer to installation manual for approved replacement battery types.