

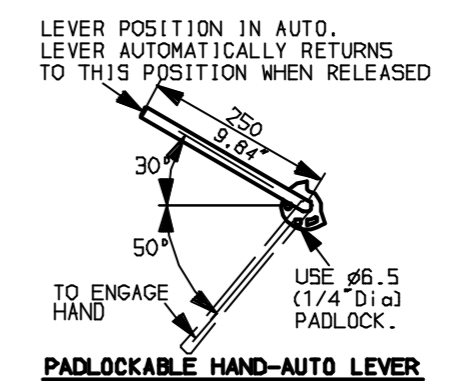

G
F
E
D
C
B
A



NOTES:
 * DIMENSIONS WITH '*' INDICATE COVER REMOVAL ALLOWANCE
 : NETT WEIGHT = 970kg (2134lbs)
 :  = OIL FILLER/DRAIN PLUG
 : THE INTERFACE PROVIDED FOR MOUNTING THE ACTUATOR OR SECOND STAGE GEARBOX ONTO THE VALVE SHOULD CONFORM TO GOOD ENGINEERING PRACTICES, ENSURING ADEQUATELY TOLERANCED LIMITS FOR PARALLELISM, PERPENDICULARITY AND CONCENTRICITY.

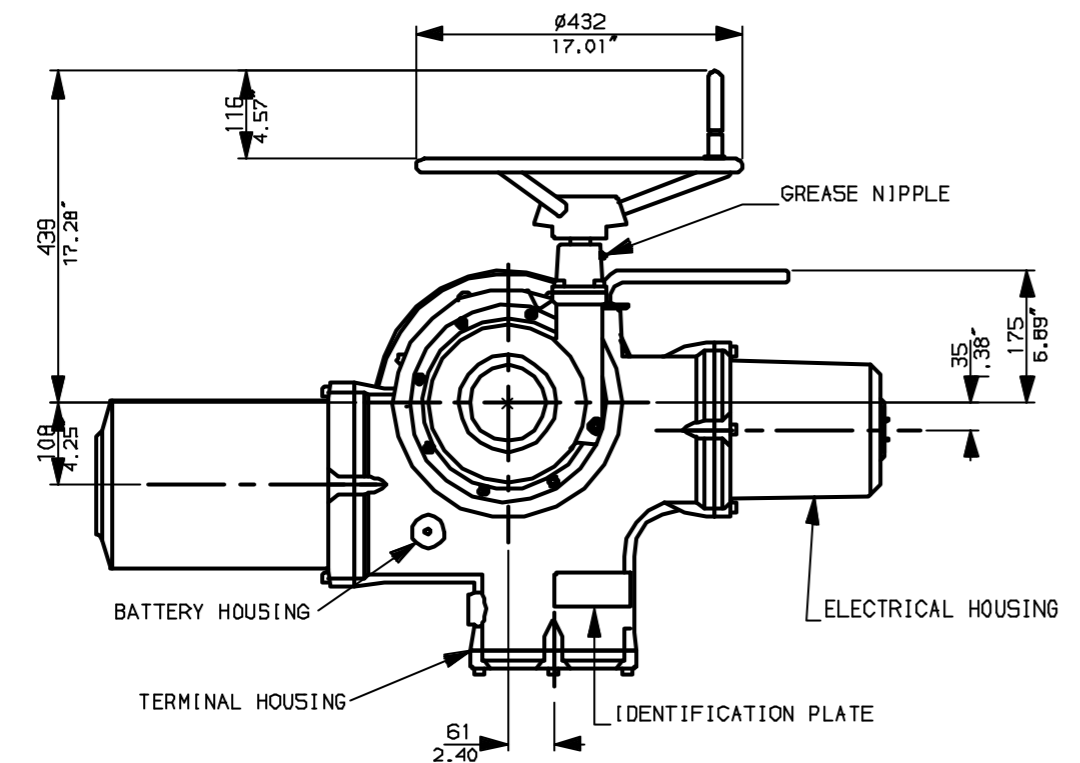

CONDUIT ENTRIES (N.T.S)

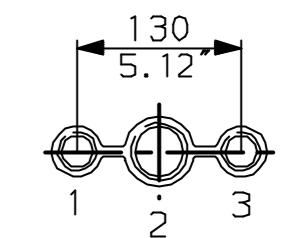

Nos.1 & 3 TAPPED 1" NPT
 No.2 TAPPED 1 1/2" NPT
 STD ALTERNATIVES IF SPECIFIED
 2 X M25, 1 X M40
 2 X PG16, 1 X PG29

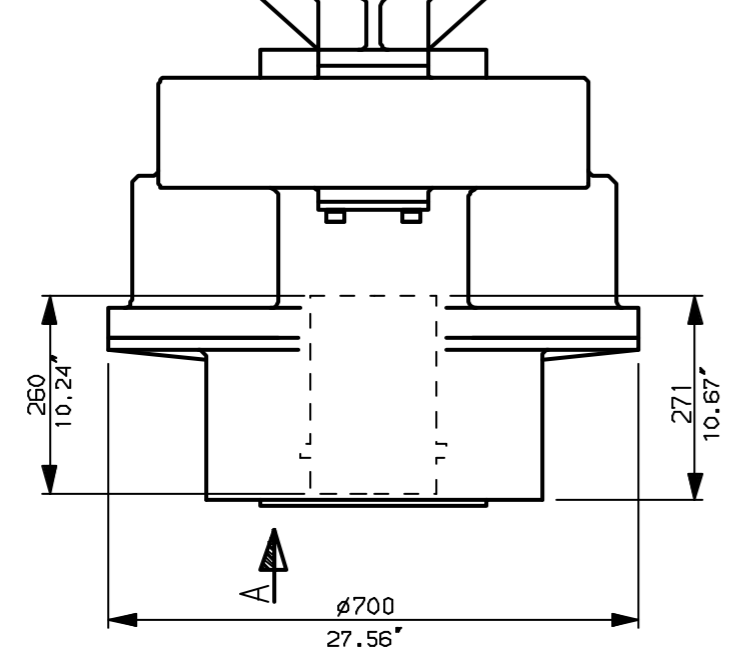
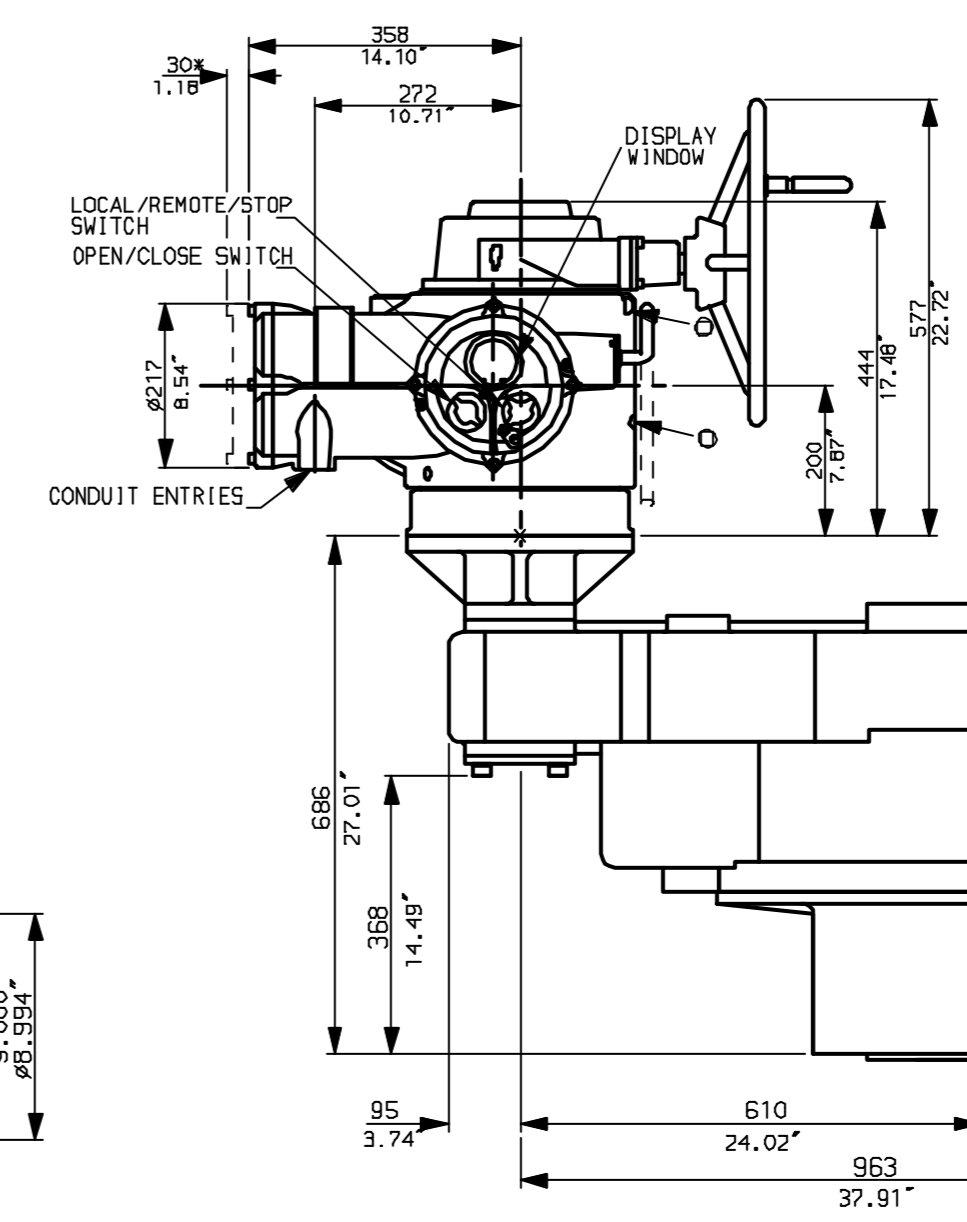
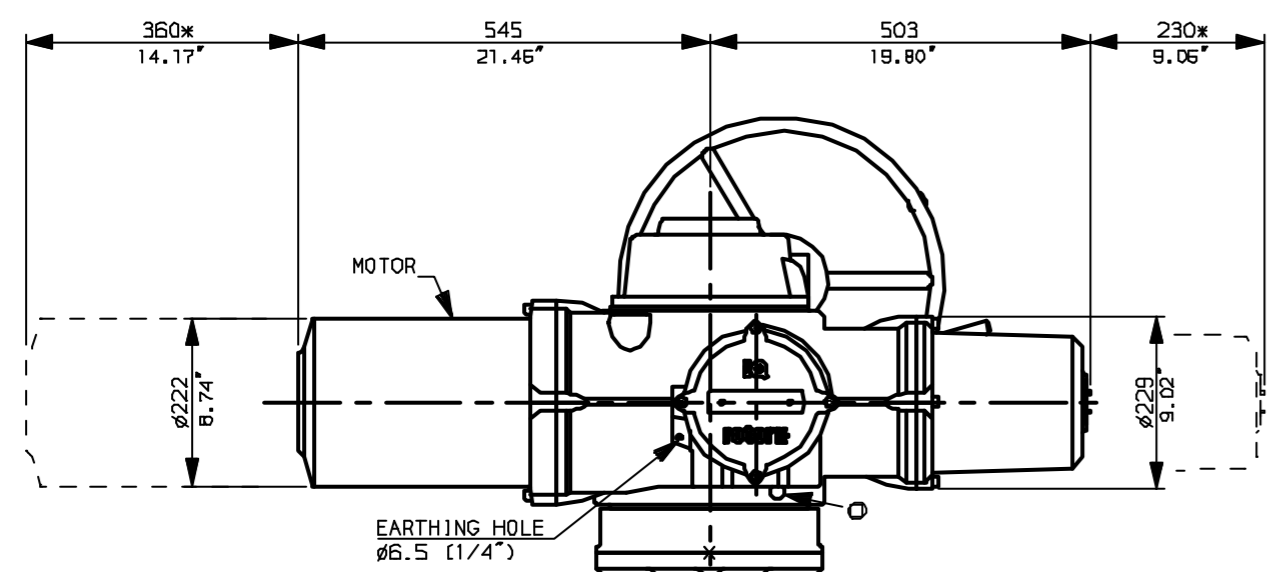

"F" version
 8 HOLES TAPPED M36x45 DP
 EQUI-SPACED AS SHOWN
 ON A 406 PCD.
 (ISO 5210-F40)
 "FA" version
 8 HOLES TAPPED 1.25"UNCx1.8"dp
 EQUI-SPACED AS SHOWN
 ON A 16" PCD.
 (MSS 5P102-FA40)

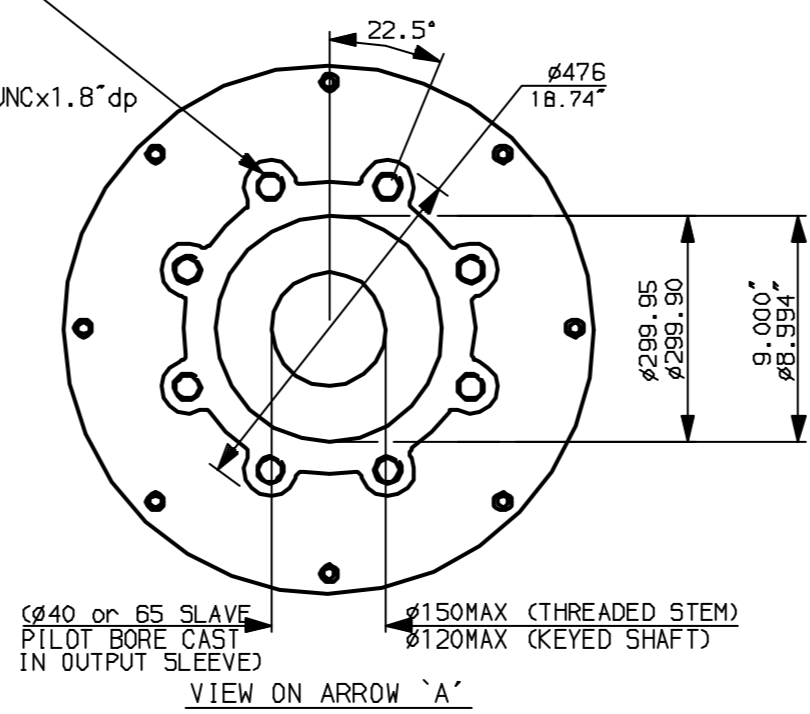

Rotork Controls Ltd.
 Bath England, BA1 3JQ.
 (Phone 01225-733200)
 Rotork Controls Inc.
 Rochester, NY 14624
 (Phone 585-328-1550)

Title IQ91, SHW, IS18,		
STANDARD DIMENSIONAL DATA		
Drawn Cad	Checked PRE	Ref Data Sheet
Date April 04	Job No	IQ91SHW_IS18

01	First Issue.
Scale	1:10 THIRD ANGLE PROJECTION
Drawing Number	IQ91SHW_IS18

1 | 2 | 3 | 4 | 5 | 6 | 7 | 8 | 9 | 10

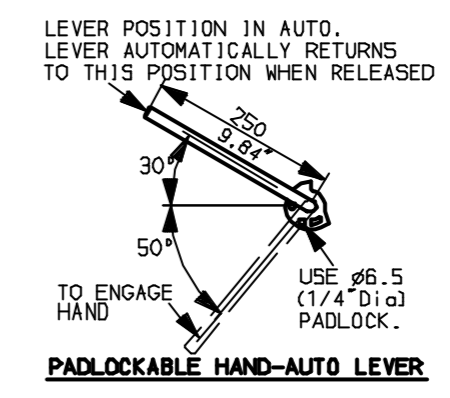
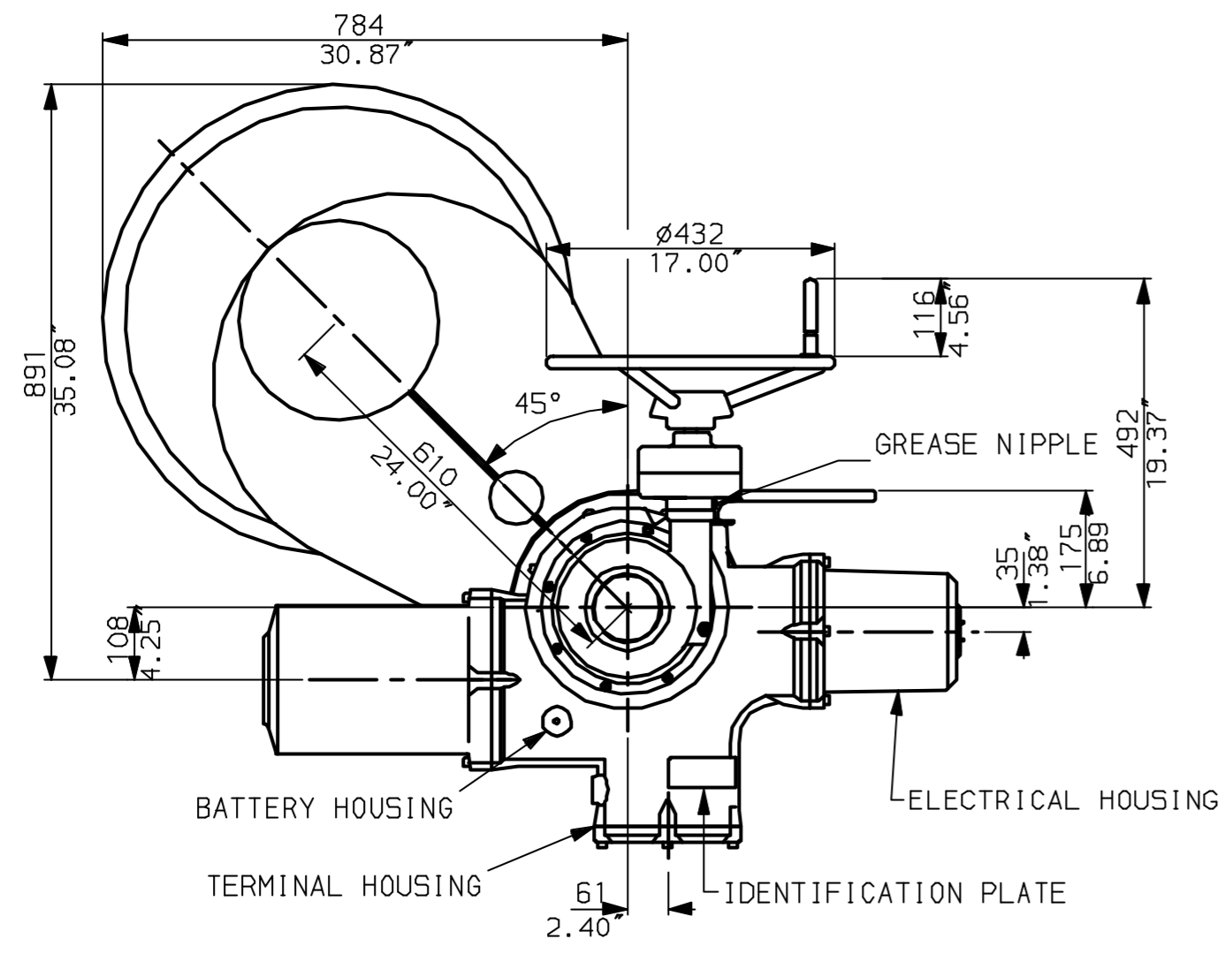

NOTES:

- DIMENSIONS WITH '*' INDICATE COVER REMOVAL ALLOWANCE
- NETT WEIGHT = 970kg (2134lbs)
- ϕ = OIL FILLER/DRAIN PLUG
- THE INTERFACE PROVIDED FOR MOUNTING THE ACTUATOR OR SECOND STAGE GEARBOX ONTO THE VALVE SHOULD CONFORM TO GOOD ENGINEERING PRACTICES, ENSURING ADEQUATELY TOLERANCED LIMITS FOR PARALLELISM, PERPENDICULARITY AND CONCENTRICITY.

CONDUIT ENTRIES (N.T.S)

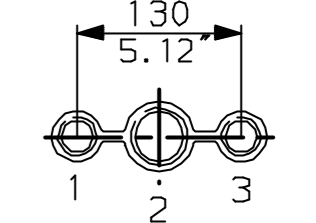

Nos.1 & 3 TAPPED 1" NPT
 No.2 TAPPED 1 1/2" NPT
 STD ALTERNATIVES IF SPECIFIED
 2 X M25, 1 X M40
 2 X PG16, 1 X PG29

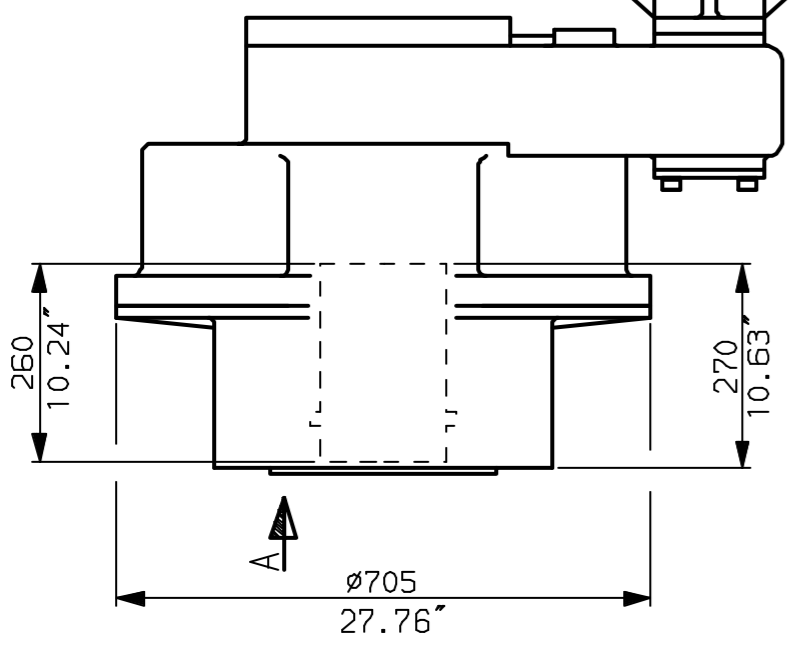
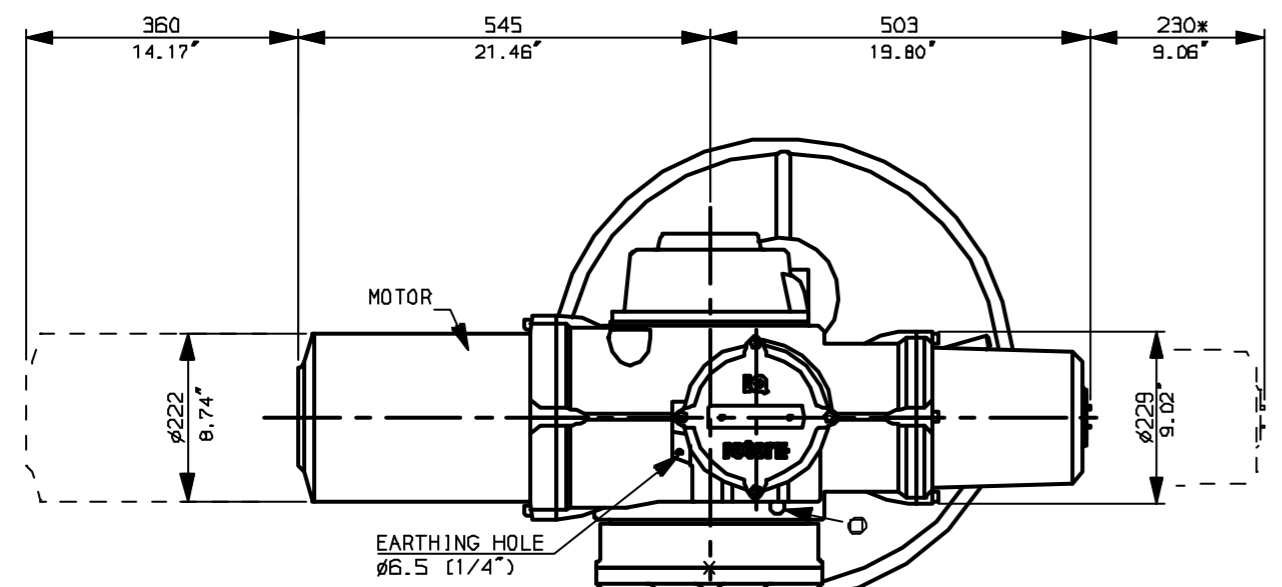

"F" version

8 HOLES TAPPED M36x45 DP
 EQUI-SPACED AS SHOWN
 ON A 406 PCD.
 (ISO 5210-F40)

"FA" version

8 HOLES TAPPED 1.25"UNCx1.8"dp
 EQUI-SPACED AS SHOWN
 ON A 15" PCD.
 (MSS 5P102-FA40)

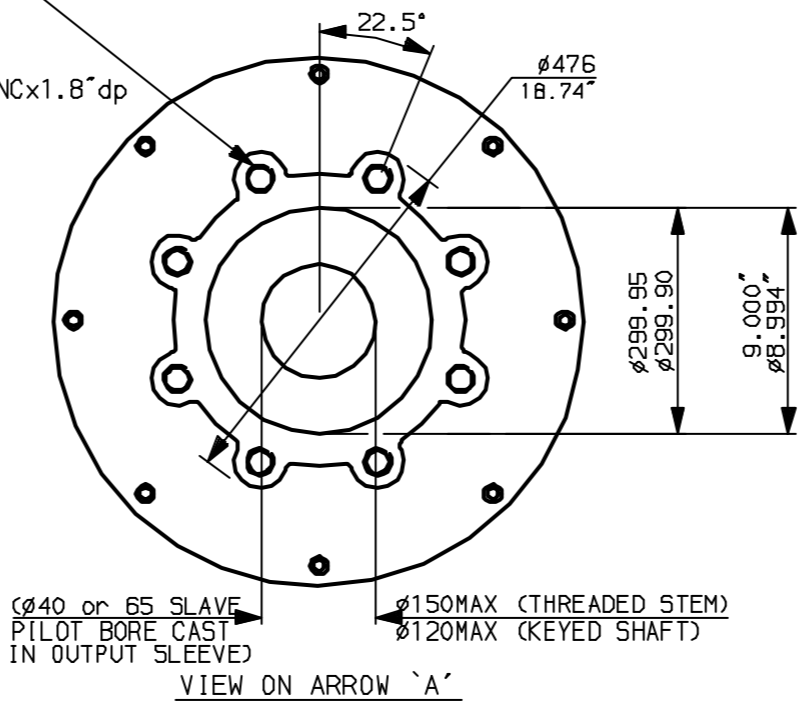

$\phi 40$ or $\phi 65$ SLAVE PILOT BORE CAST IN OUTPUT SLEEVE
 $\phi 150$ MAX (THREADED STEM)
 $\phi 120$ MAX (KEYED SHAFT)

VIEW ON ARROW 'A'

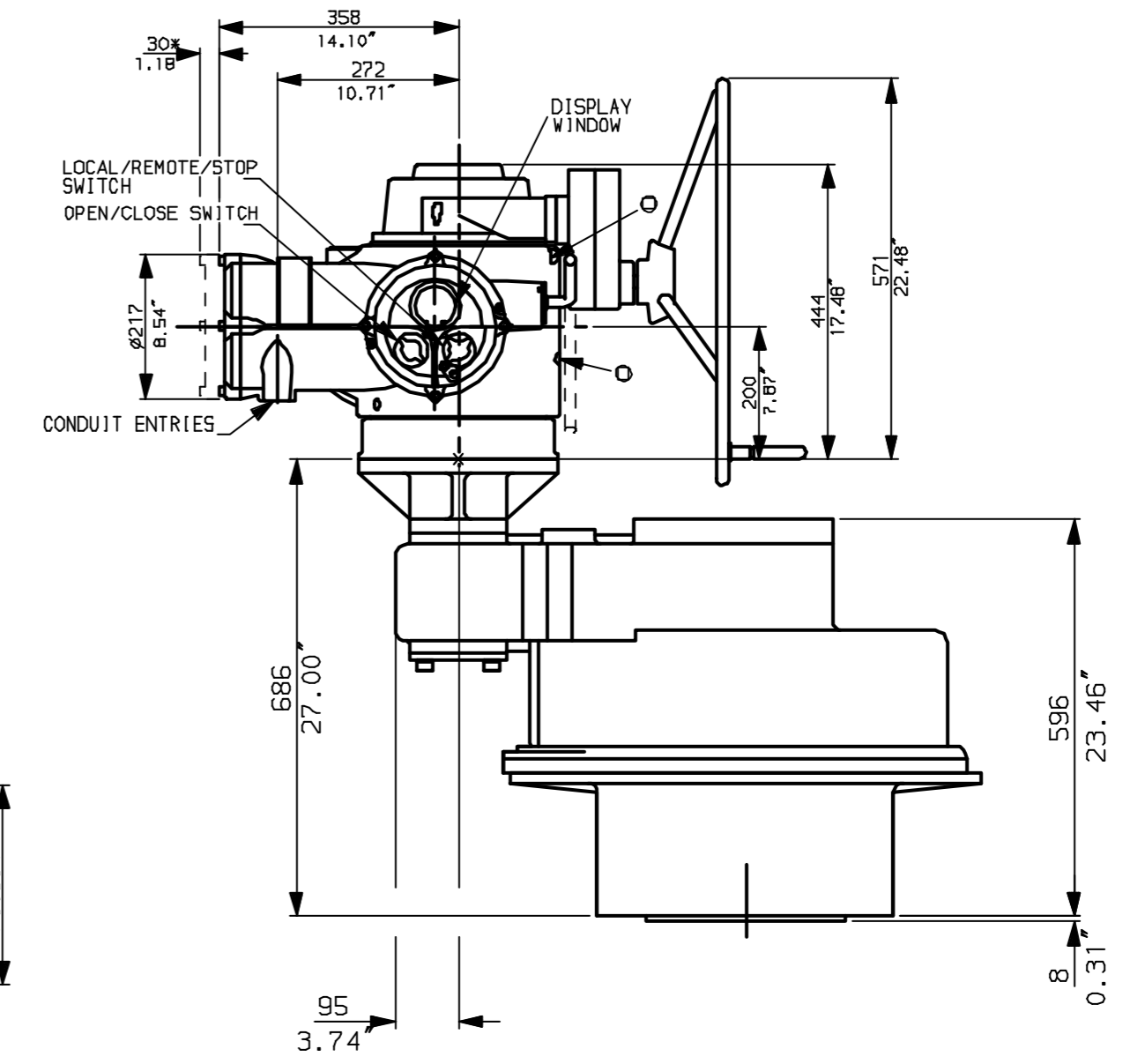

Rotork Controls Ltd.
 Bath England, BA1 3JQ.
 (Phone 01225-733200)

Rotork Controls Inc.
 Rochester, NY 14624
 (Phone 585-328-1550)

Title IQ91, SSHW, IS18,		
STANDARD DIMENSIONAL DATA		
Drawn Cad	Checked PRE	Ref Data Sheet
Date April 04	Job No	IQ91SSHW_IS18

01	First Issue.
Scale	1:10 THIRD ANGLE PROJECTION
Drawing Number	IQ91SSHW_IS18