

LEVER POSITION IN AUTO.
LEVER AUTOMATICALLY RETURNS
TO THIS POSITION WHEN RELEASED

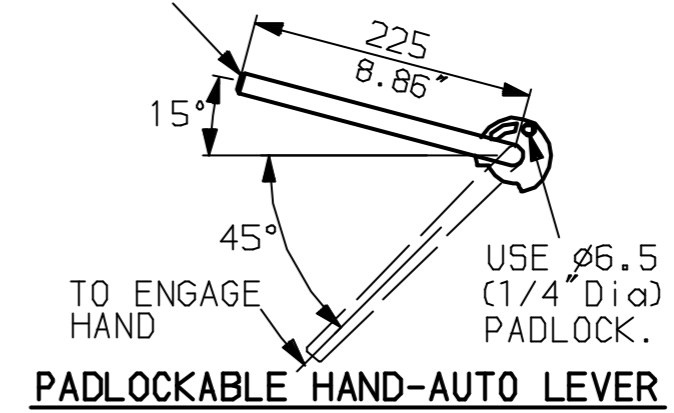

NOTES:
DIMENSIONS WITH '*' INDICATE
COVER REMOVAL ALLOWANCE
NETT WEIGHT = 63kg (139lbs)
○ = OIL FILLER/DRAIN PLUG
THE INTERFACE PROVIDED FOR MOUNTING THE
ACTUATOR OR SECOND STAGE GEARBOX ONTO THE
VALVE SHOULD CONFORM TO GOOD ENGINEERING
PRACTICES, ENSURING ADEQUATELY TOLERANCED
LIMITS FOR PARALLELISM, PERPENDICULARITY
AND CONCENTRICITY.

CONDUIT ENTRIES (N.T.S)

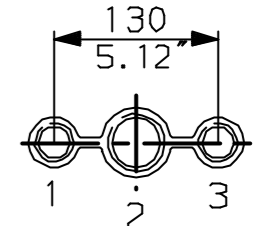

Nos.1 & 3 TAPPED 1" NPT
No.2 TAPPED 1 1/2" NPT
STD ALTERNATIVES IF SPECIFIED
2 X M25, 1 X M40
2 X PG16, 1 X PG29

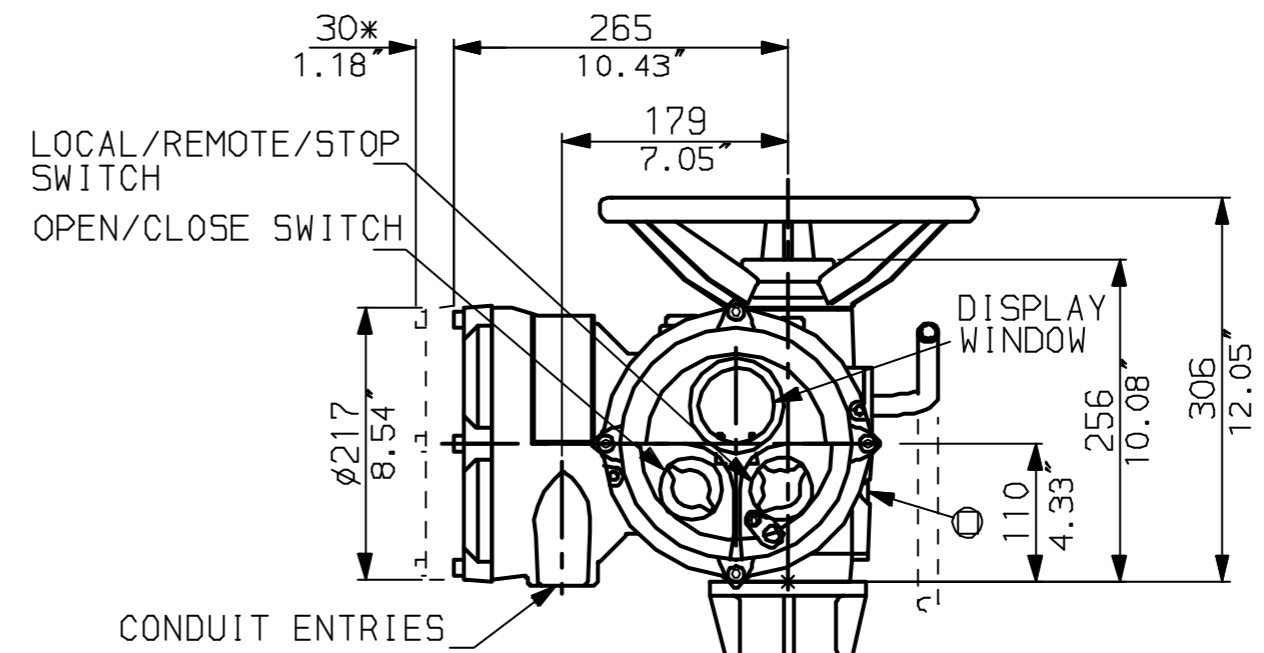
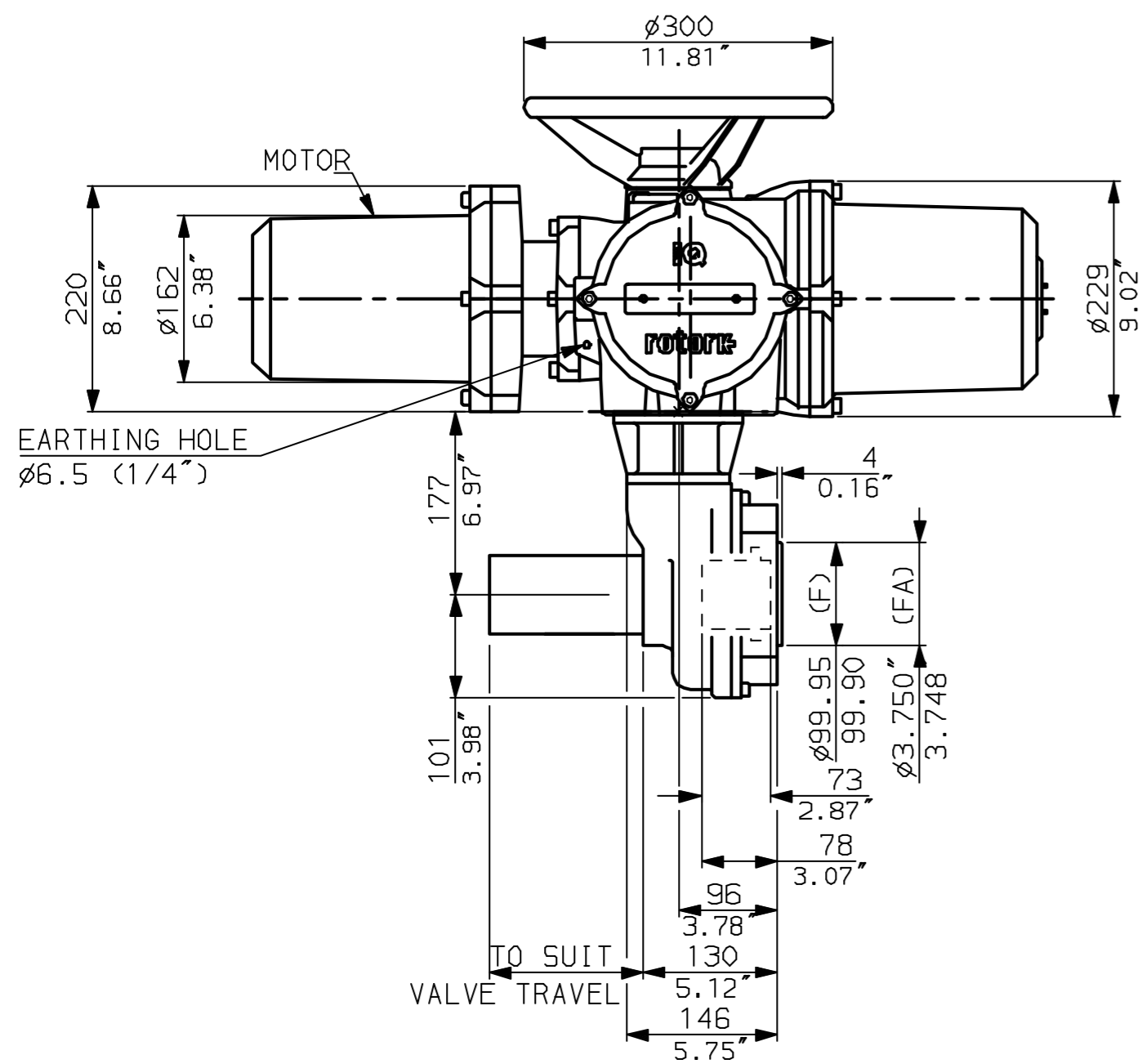

"F" version

4 HOLES TAPPED M16x20 DP
EQUI-SPACED ON A 140 PCD
(1S05210 F14).

"FA" version

4 HOLES TAPPED 5/8" UNC
x0.80" dp EQUI-SPACED ON
5.5" PCD (MSS SP102-FA14).

rotork
www.rotork.com

Rotork Controls Ltd.
Bath England, BA1 3JQ.
(Phone 01225-733200)
Rotork Controls Inc.
Rochester, NY 14624
(Phone 585-328-1550)

Title IQD10, 12, 18, THW, IB5,		
STANDARD DIMENSIONAL DATA		
Drawn CAD	Checked PRE	Ref Data Sheet
Date April 04	Job No IQD1THW_IB5	

01	First Issue.
Scale 1:6	THIRD ANGLE PROJECTION
Drawing Number	IQD1THW_IB5

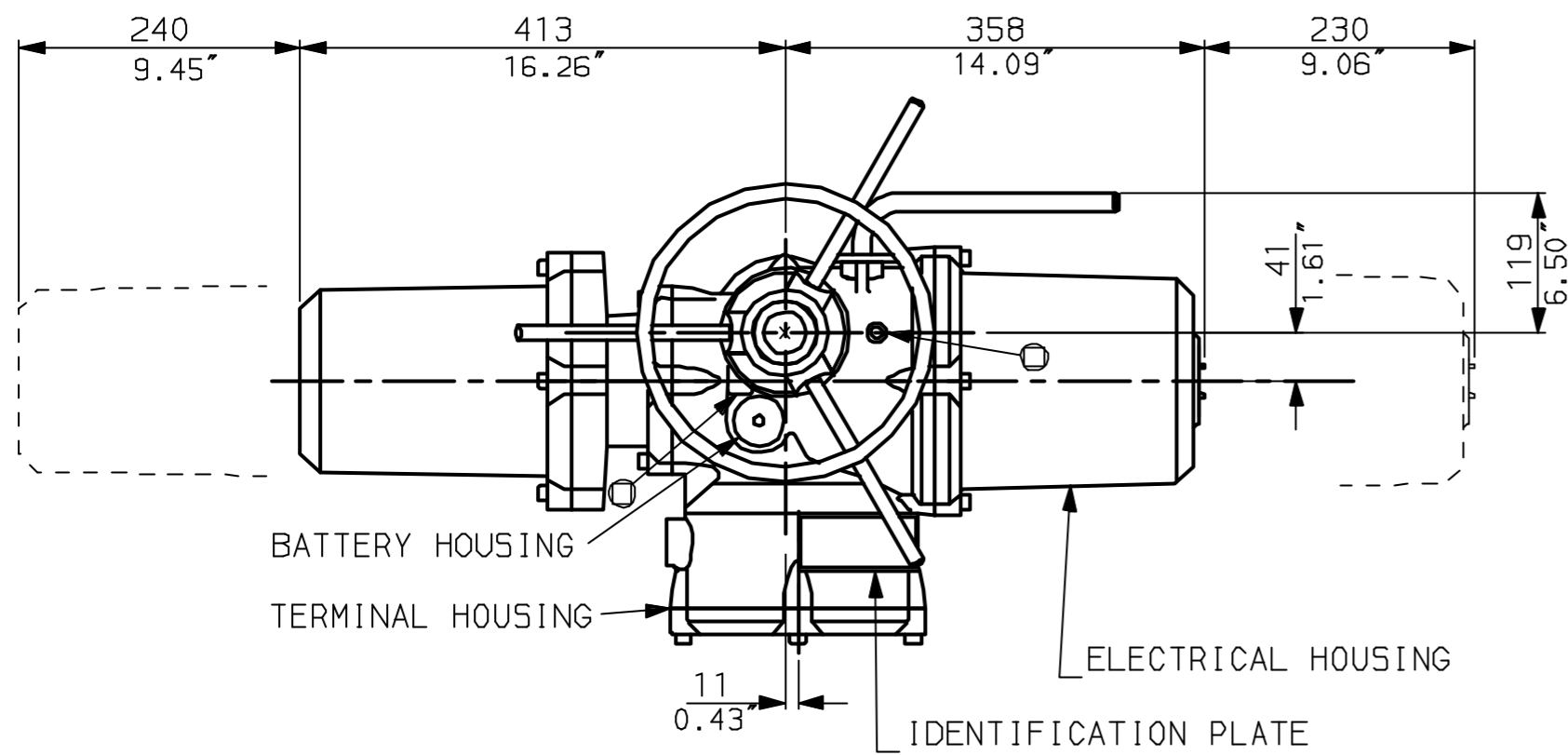

LEVER POSITION IN AUTO.
LEVER AUTOMATICALLY RETURNS
TO THIS POSITION WHEN RELEASED

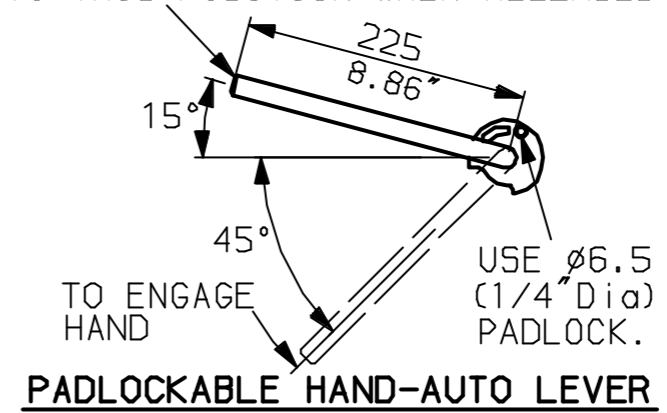

NOTES:
DIMENSIONS WITH '*' INDICATE
COVER REMOVAL ALLOWANCE
NETT WEIGHT = 63kg (139lbs)
☉ = OIL FILLER/DRAIN PLUG
THE INTERFACE PROVIDED FOR MOUNTING THE
ACTUATOR OR SECOND STAGE GEARBOX ONTO THE
VALVE SHOULD CONFORM TO GOOD ENGINEERING
PRACTICES, ENSURING ADEQUATELY TOLERANCED
LIMITS FOR PARALLELISM, PERPENDICULARITY
AND CONCENTRICITY.

CONDUIT ENTRIES (N.T.S)

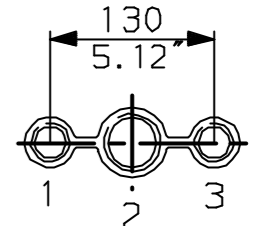

Nos.1 & 3 TAPPED 1" NPT
No.2 TAPPED 1 1/2" NPT
STD ALTERNATIVES IF SPECIFIED
2 X M25, 1 X M40
2 X PG16, 1 X PG29

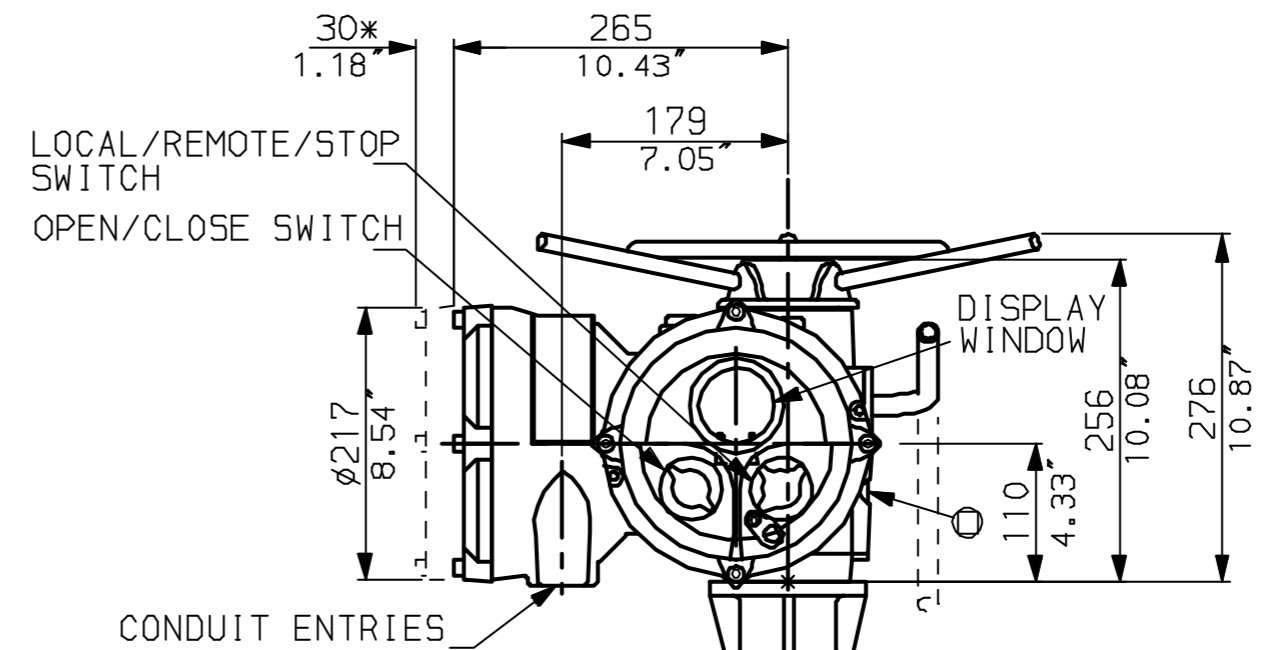
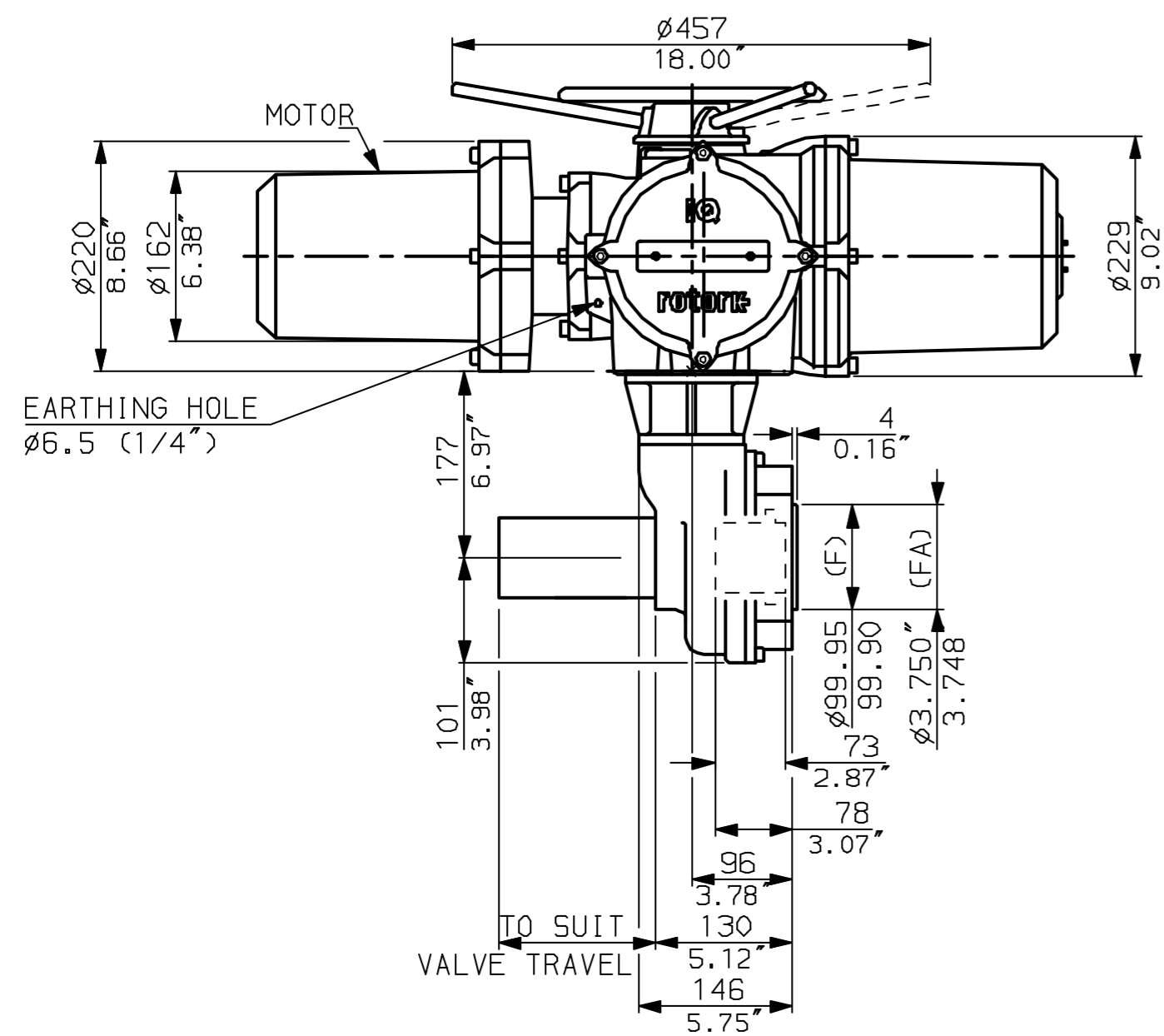

"F" version
4 HOLES TAPPED M16x20 DP
EQUI-SPACED ON A 140 PCD
(ISO5210 F14).

"FA" version
4 HOLES TAPPED 5/8"UNC
x0.80" dp EQUI-SPACED ON
5.5"PCD (MSS SP102-FA14).

rotork
www.rotork.com

Rotork Controls Ltd.
Bath England, BA1 3JQ.
(Phone 01225-733200)
Rotork Controls Inc.
Rochester, NY 14624
(Phone 585-328-1550)

Title IQD10, 12, 18, LTHW, IB5,		
STANDARD DIMENSIONAL DATA		
Drawn CAD	Checked PRE	Ref Data Sheet
Date April 04	Job No IQD1LTHW_IB5	

01	First Issue.
Scale 1:6	THIRD ANGLE PROJECTION
Drawing Number	IQD1LTHW_IB5

