

Suitable for 150 series insert

DESCRIPTION:

TRAVEL : -5° TO 95° adjustable
 RATIO : 226 : 1
 TURNS TO CLOSE : 57.5
 WEIGHT : 28.5 kg. (63 lb.) Excl. handwheel

MOUNTING HOLES :

BOLT CIRCLE : min. Ø 102 [4.02]
 (OFF CENTER) max. Ø 165 [6.40]
 acc. ISO 5211 : F10-F12-F14-F16
 MIN. bore insert : Ø 16 [0.63]
 MAX. bore insert : ∇ 36 [1.42] or Ø 44 [1.77]

TORQUE :

max. OUTPUT : 3250 Nm (28765 lbf.in.)
 max. INPUT : 53 Nm (469 lbf.in.)
 MA : 61.3 ± 15%

DIMENSIONS IN MM [INCH]

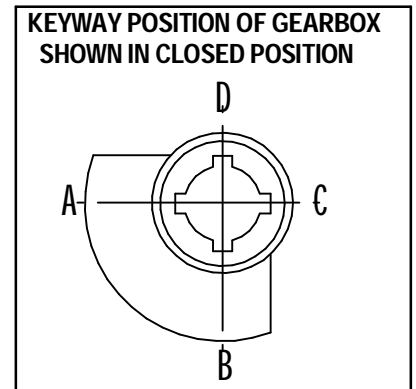

ROTORK GEARS

GEARBOX AB1250N-PR4

DRAWN:- Robbin Goosen CHECKED:- Henk Hoff

DWG:- AB1250N-PR4 insert

REV:01