

**DESCRIPTION:**

TRAVEL : -5° TO 95° adjustable  
 RATIO : 217 : 1  
 TURNS TO CLOSE : 54.34  
 WEIGHT : 39 kg. (85 lb.) Excl. handwheel

**MOUNTING HOLES :**

BOLT CIRCLE : min. Ø 125 [4.92]  
 (OFF CENTER) : max. Ø 254 [10.00]  
 acc. ISO 5211 : F12 - F14 - F16 - F25  
 Min. bore Quadrant : Ø 30 [1.18]  
 MAX. bore Quadrant :  $\nabla$  60 [2.36] or Ø 80 [3.15]

**TORQUE :**

max. OUTPUT : 7000 Nm (6195 lbf.in.)  
 max. INPUT : 106 Nm (939 lbf.in.)  
 MA : 66.0 ± 15%

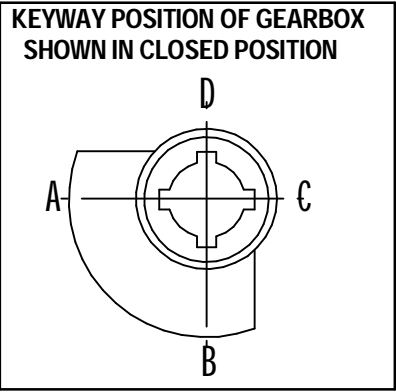

DIMENSIONS IN MM [INCH]