

Suitable for 240 series insert

DESCRIPTION:

TRAVEL : -5° TO 95° adjustable
 RATIO : 217 : 1
 TURNS TO CLOSE : 54.34
 WEIGHT : 52 kg. (114.4 lb.) Excl. handwheel

MOUNTING HOLES :

BOLT CIRCLE : min. Ø 125 [4.92]
 (OFF CENTER) : max. Ø 298 [11.73]
 acc. ISO 5211 : F12 - F14 - F16 - F25-F30
 Min. bore insert : Ø 16 [0.63]
 MAX. bore insert : ∇ 46 [1.81] or Ø 55 [2.05]

TORQUE :

max. OUTPUT : 7000 Nm (6195 lbf.in.)
 max. INPUT : 106 Nm (939 lbf.in.)
 MA : 66.0 ± 15%

DIMENSIONS IN MM [INCH]

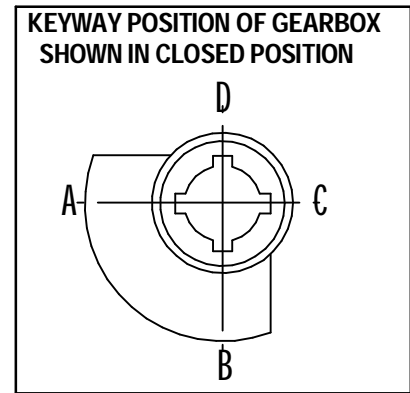

ROTORK GEARS

GEARBOX AB1950N-PR4 LB

DRAWN:- Robbin Goosen CHECKED:- Henk Hoff

DWG:- AB1950N-PR4 LB insert

REV: 02