

NOTES:
 * DIMENSIONS WITH '*' INDICATE COVER REMOVAL ALLOWANCE
 : NETT WEIGHT = 534kg (1175lbs)
 : \odot = OIL FILLER/DRAIN PLUG
 : THE INTERFACE PROVIDED FOR MOUNTING THE ACTUATOR OR SECOND STAGE GEARBOX ONTO THE VALVE SHOULD CONFORM TO GOOD ENGINEERING PRACTICES, ENSURING ADEQUATELY TOLERANCED LIMITS FOR PARALLELISM, PERPENDICULARITY AND CONCENTRICITY.

CONDUIT ENTRIES (N.T.S)

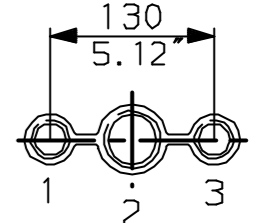

Nos.1 & 3 TAPPED 1" NPT
 No.2 TAPPED 1 1/2" NPT
 STD ALTERNATIVES IF SPECIFIED
 2 X M25, 1 X M40
 2 X PG16, 1 X PG29

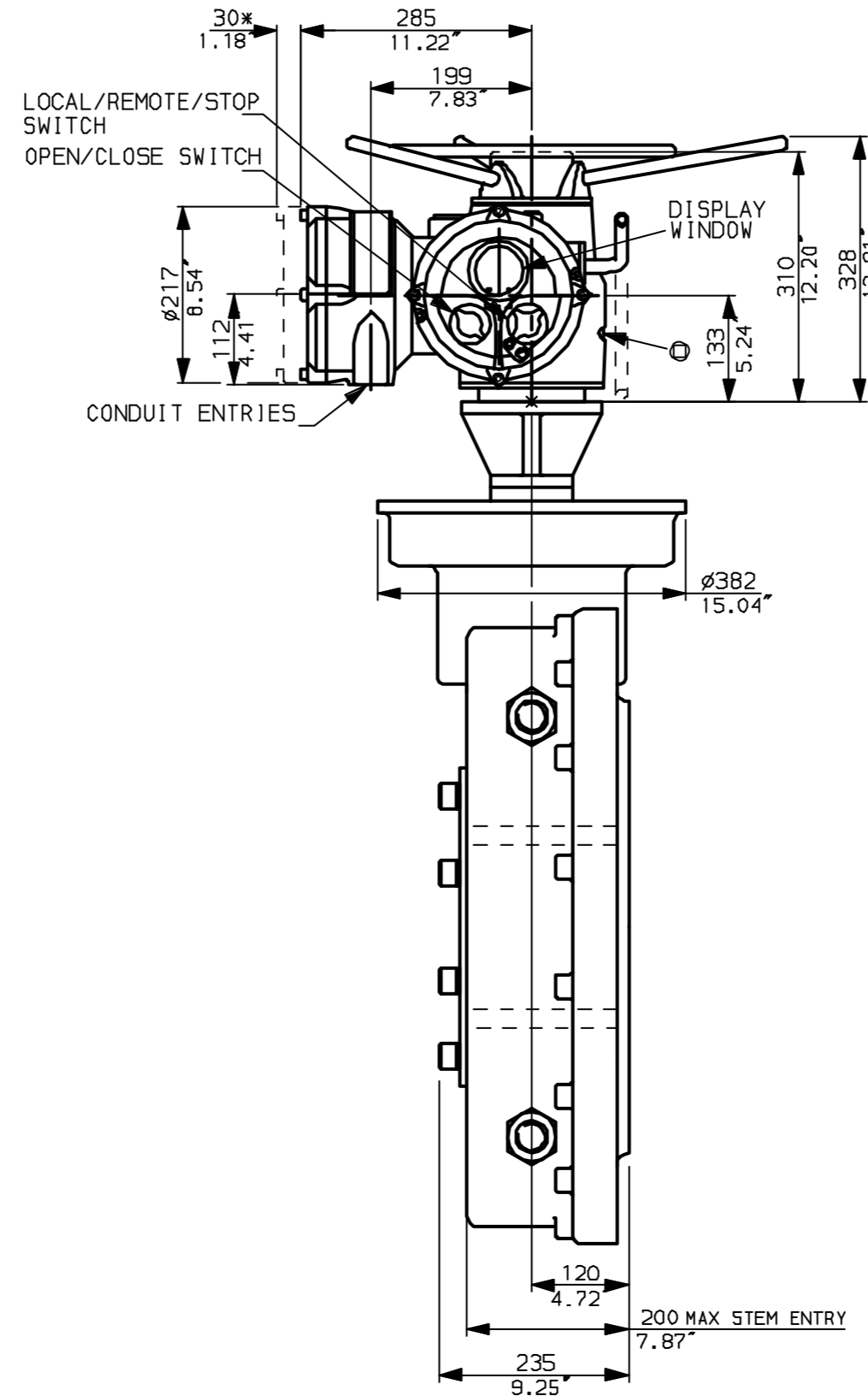
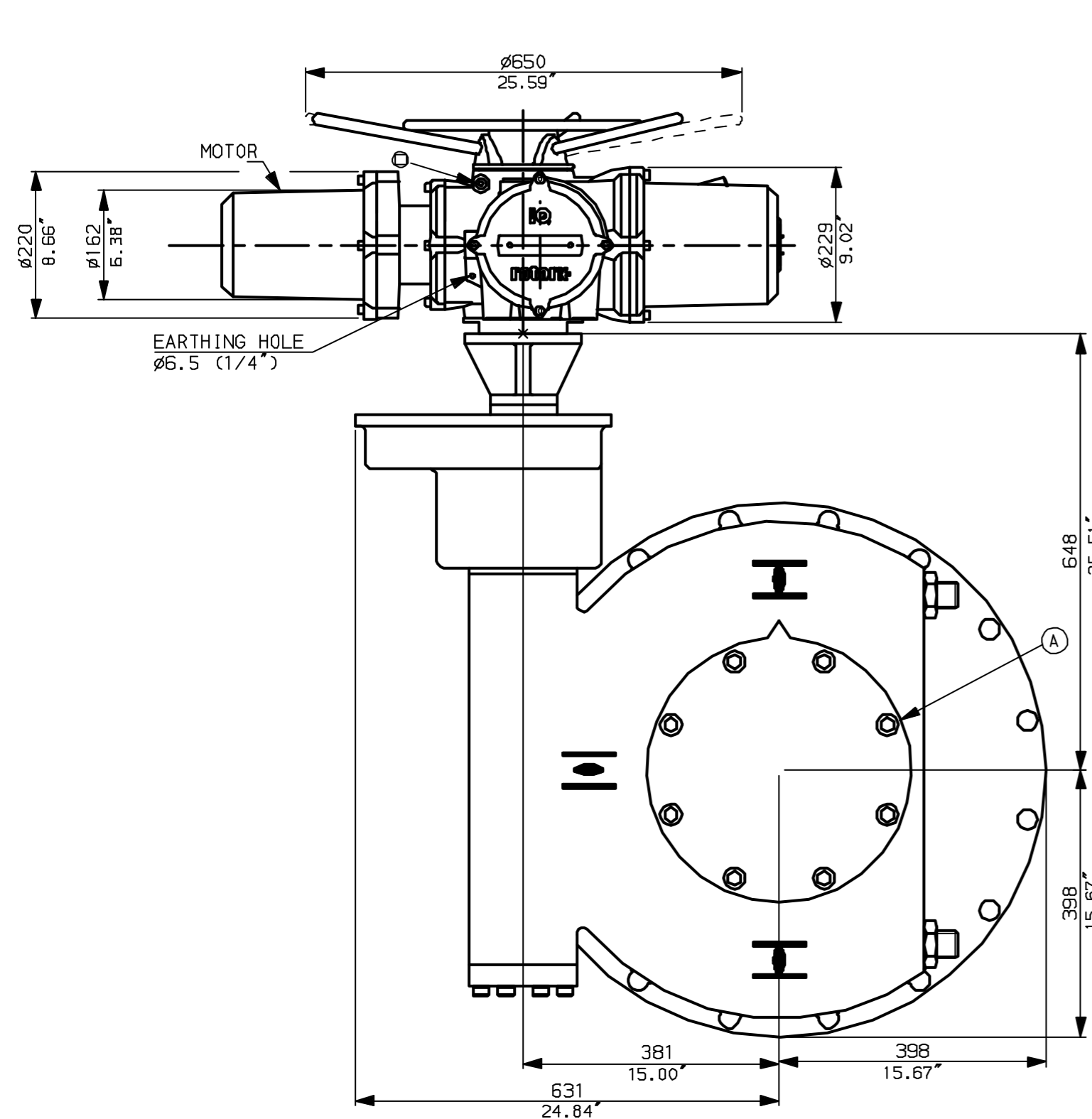

N.B. KEYWAY POS. CAN BE MOVED IN 45° STEPS BY REMOVING 8 SCREWS MARKED (A) AND ROTATING OUTPUT SLEEVE.

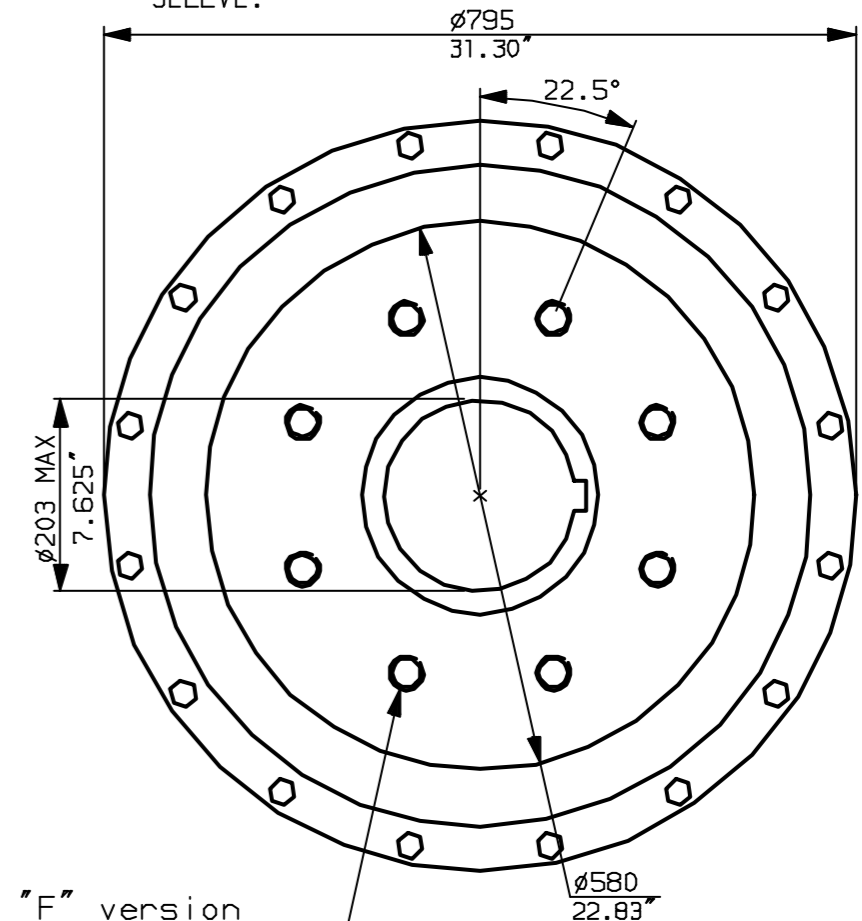

"F" version
 8 HOLES TAPPED M36 x 36 DP
 EQUI-SPACED AS SHOWN ON A
 406 PCD (ISO 5211-F40).
 "FA" version
 8 HOLES TAPPED 1.25"UNCx1.42"dp
 EQUI-SPACED AS SHOWN ON A
 16" PCD (MSS SP101-FA40).



Rotork Controls Ltd.
 Bath England, BA1 3JQ.
 (Phone 01225-733200)
 Rotork Controls Inc.
 Rochester, NY 14624
 (Phone 585-328-1550)

Title IQD20, THW, IW11 (+115)R,		
STANDARD DIMENSIONAL DATA		
Drawn CAD	Checked PRE	Ref Data Sheet
Date April 04	Job No IQD20THW_IW11R	

01	First Issue.
Scale	1:8 THIRD ANGLE PROJECTION
Drawing Number	IQD20THW_IW11R

