

DESCRIPTION				MOUNTING HOLES - BOLT CIRCLE OFF CENTRES				BORE; STEM ACCEPTANCE WITH KEYWAY IN ACCORDING WITH STANDARD			TORQUE		
RATIO	TURNS TO CLOSE	TRAVEL (1/4 TURN)	WEIGHT	NR of HOLES	MIN ENVELOP PCD - ØHOLE	MAX ENVELOP PCD + ØHOLE	ACCORDING TO ISO 5211 / MSS SP-101	MIN	MAX	STANDARD	OUTPUT	INPUT	MA
217:1	54.25	-5° TO 95°	52 kg	4	Ø 104 mm	Ø 340 mm	F12-F14-F16	Ø 16 mm	Ø 55 mm	DIN 6885-1	7000 Nm	106 Nm	66.0u 15%
				8	Ø 104 mm	Ø 340 mm	F25-F30						
			115 lbs	4	Ø 4.09 inch	Ø 13.39 inch	FA12-FA14-FA16	Ø 0.63 inch	Ø 2.05 inch	ANSI B17.1	61955 lbf.in.	1221 lbf.in.	
				8	Ø 4.09 inch	Ø 13.39 inch	FA25-FA30						

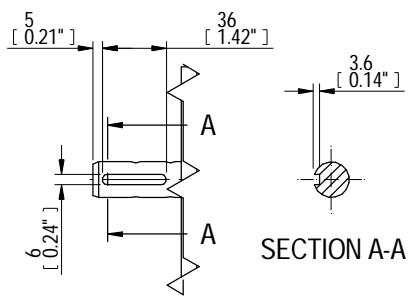

KEY DETAILS

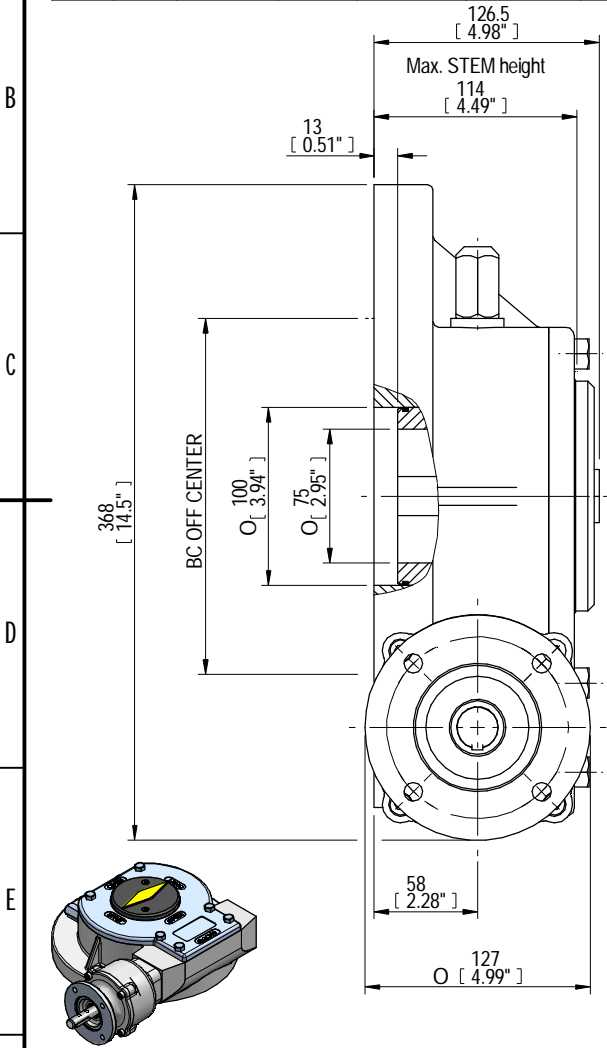
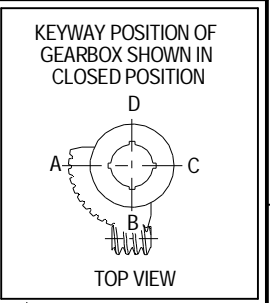
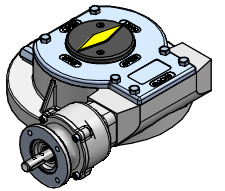
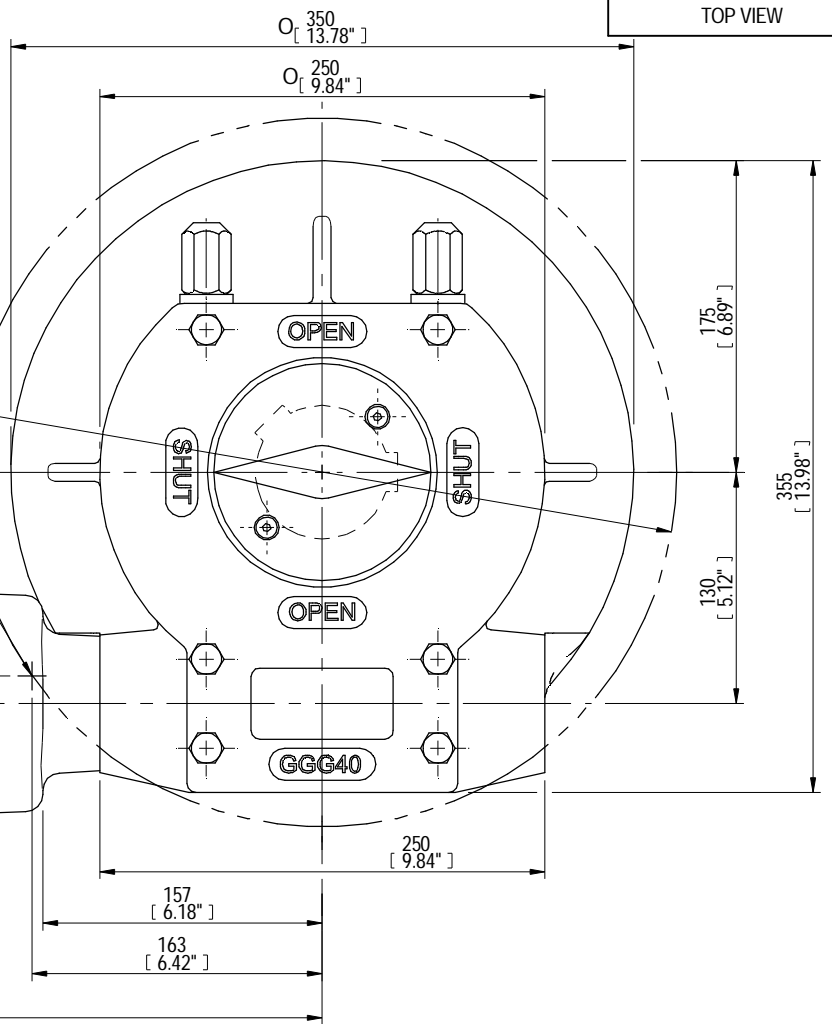
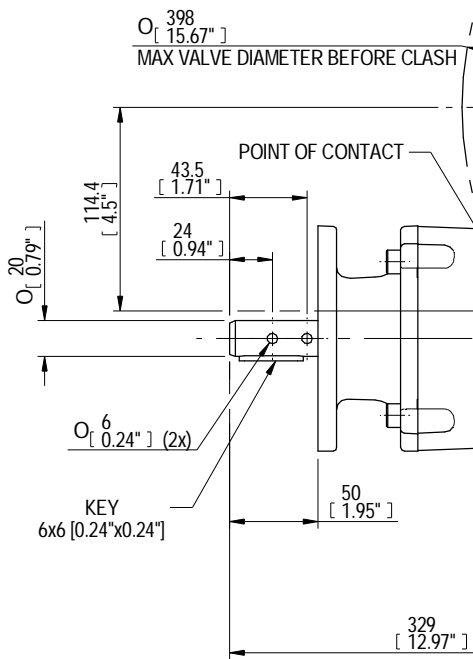

ISOMETRIC VIEW
1:10

AS PART OF CONTINUOUS PRODUCT DEVELOPMENT, ALL DETAILS SUBJECT TO CHANGE WITHOUT PRIOR NOTICE. FOR UP TO DATE DETAILS PLEASE VISIT www.rotork.com

 LOSSER - THE NETHERLANDS www.rotork.com	Document type DETAIL DRAWING		Title E1950W WITH PR4 RH PLANETARY GEARBOX-PR4	
	Dimensions in mm Scale 1:3		Drawing Number E1950W-PR4 LB insert RH	
Created	K. DANIEL	11/11/2013	Rev	A
Checked	PRABUD	15/11/2013	Sheet	1 of 1 Size A3
Approved				