

G
F
E
D
C
B
A

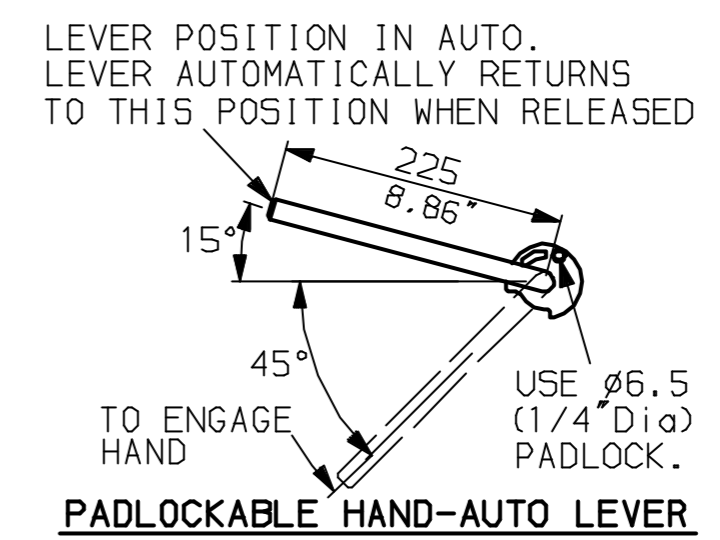

NOTES:
DIMENSIONS WITH '*' INDICATE COVER REMOVAL ALLOWANCE
NETT WEIGHT = 135kg (297lbs)
OIL FILLER/DRAIN PLUG
THE INTERFACE PROVIDED FOR MOUNTING THE ACTUATOR OR SECOND STAGE GEARBOX ONTO THE VALVE SHOULD CONFORM TO GOOD ENGINEERING PRACTICES, ENSURING ADEQUATELY TOLERANCED LIMITS FOR PARALLELISM, PERPENDICULARITY AND CONCENTRICITY.

CONDUIT ENTRIES (N.T.S)

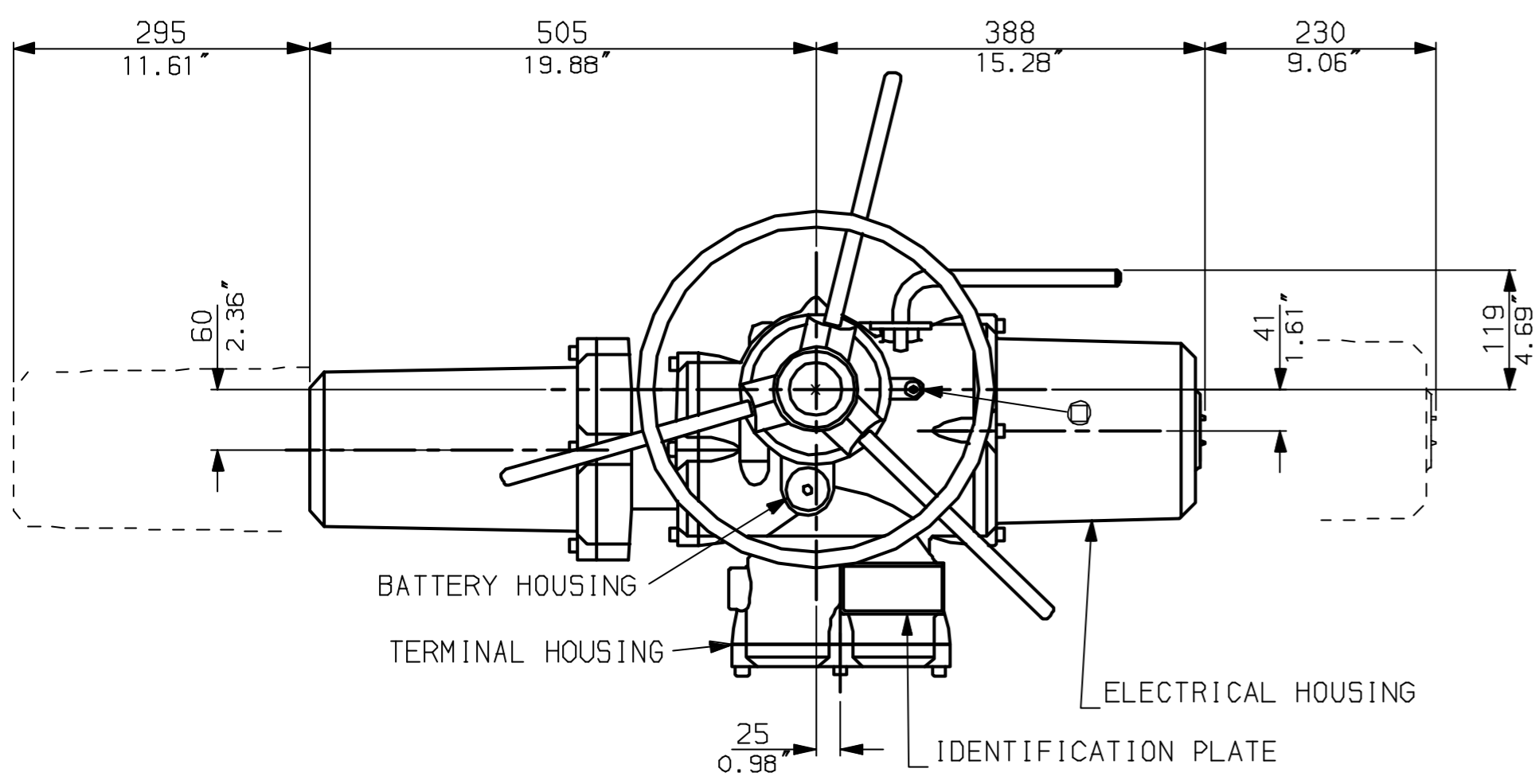
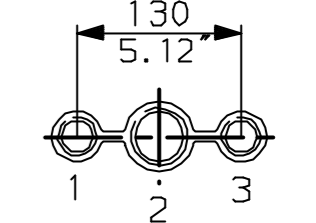

Nos.1 & 3 TAPPED 1" NPT
No.2 TAPPED 1 1/2" NPT
STD ALTERNATIVES IF SPECIFIED
2 X M25, 1 X M40
2 X PG16, 1 X PG29

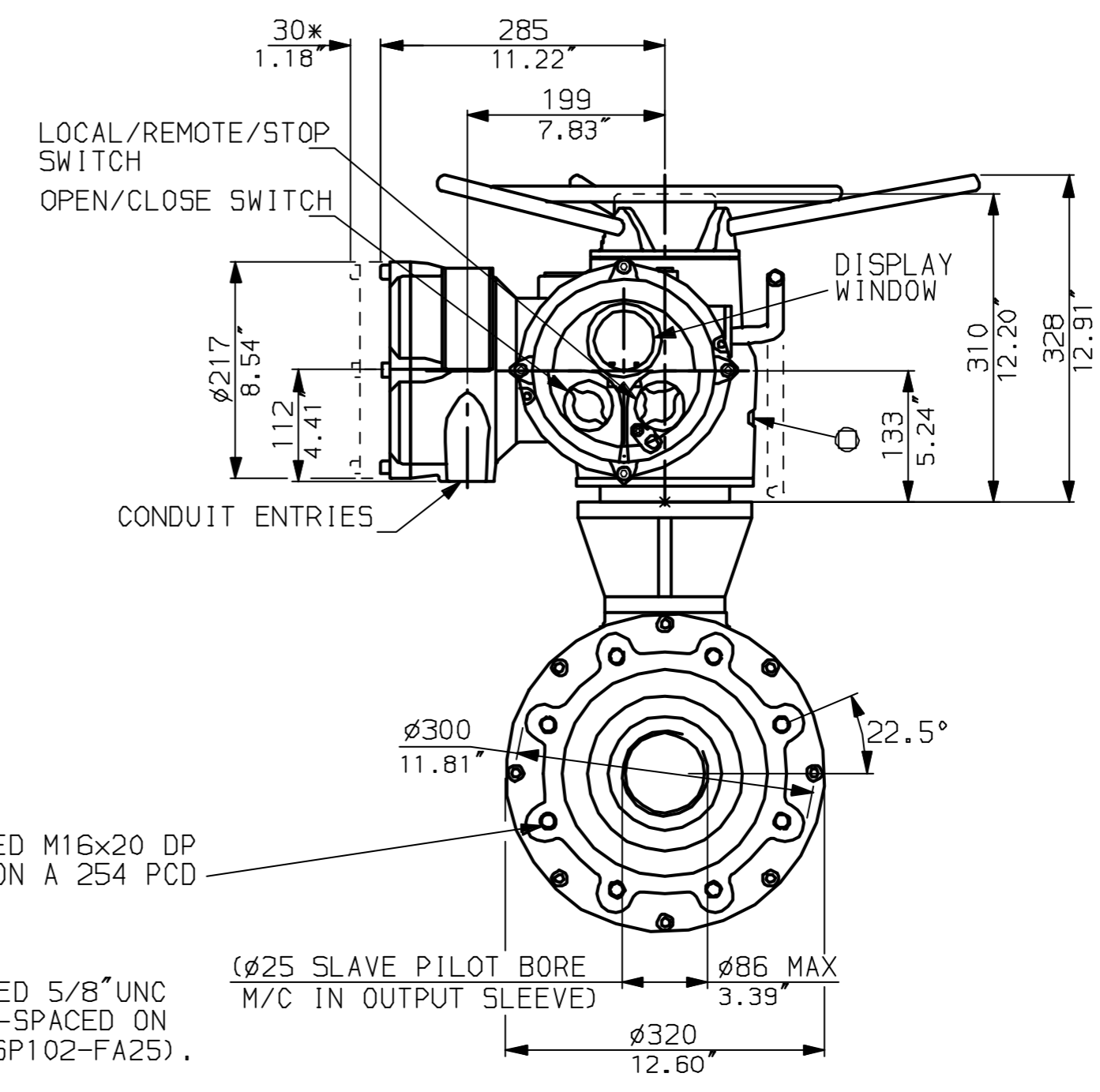
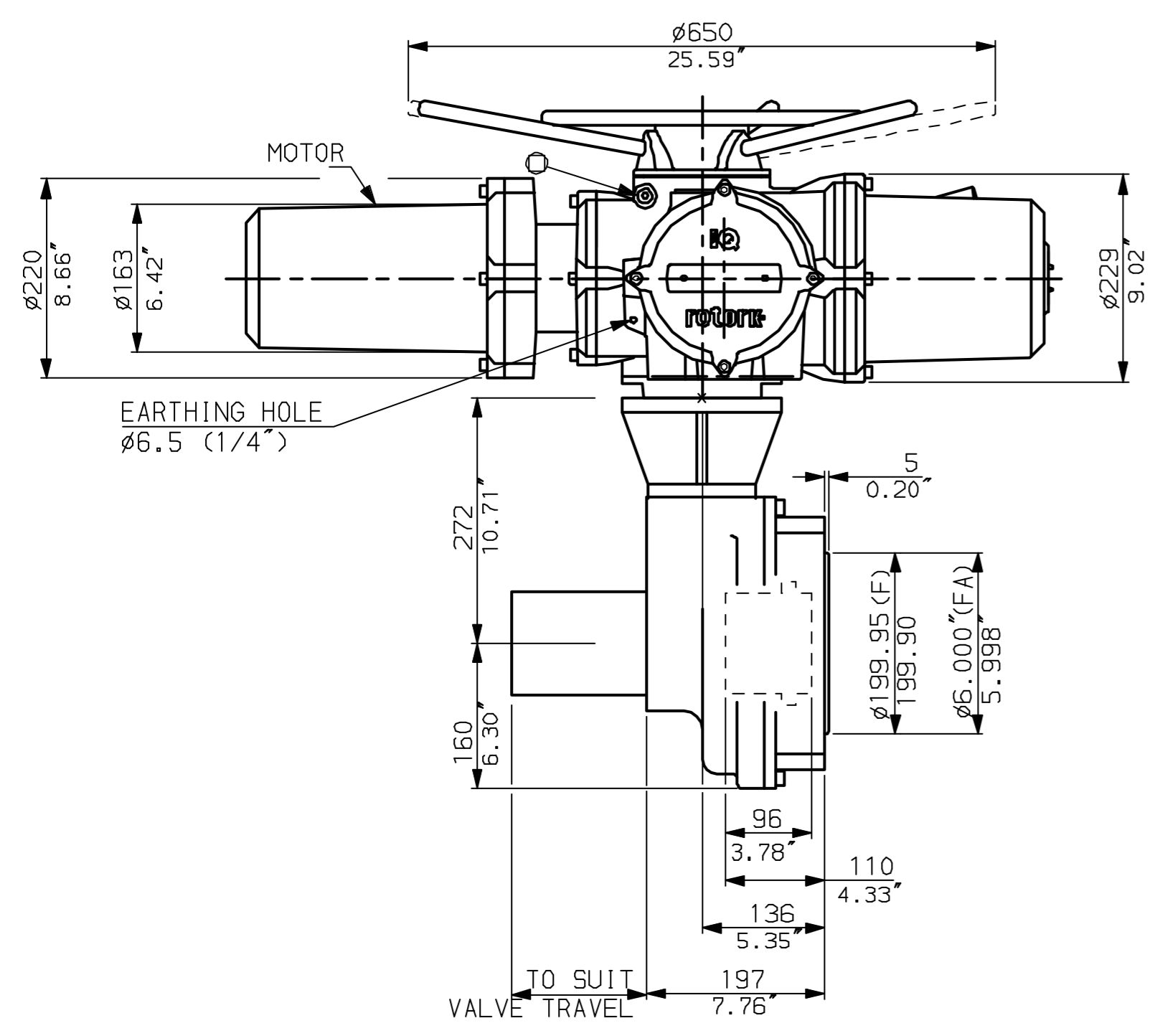

"F" version
8 HOLES TAPPED M16x20 DP
EQUI-SPACED ON A 254 PCD
(1505210 F25)

"FA" version
8 HOLES TAPPED 5/8" UNC
x0.8" dp EQUI-SPACED ON
10" PCD (M55 SP102-FA25).



Rotork Controls Ltd.
Bath England, BA1 3JQ.
(Phone 01225-733200)

Rotork Controls Inc.
Rochester, NY 14624
(Phone 585-328-1550)

Title IQD25, THW, IB9,		
STANDARD DIMENSIONAL DATA		
Drawn CAD	Checked PRE	Ref Data Sheet
Date April 04	Job No IQD25THW_IB9	

01	First Issue.
Scale	1:6 THIRD ANGLE PROJECTION
Drawing Number	IQD25THW_IB9

1 | 2 | 3 | 4 | 5 | 6 | 7 | 8 | 9 | 10

G
F
E
D
C
B
A

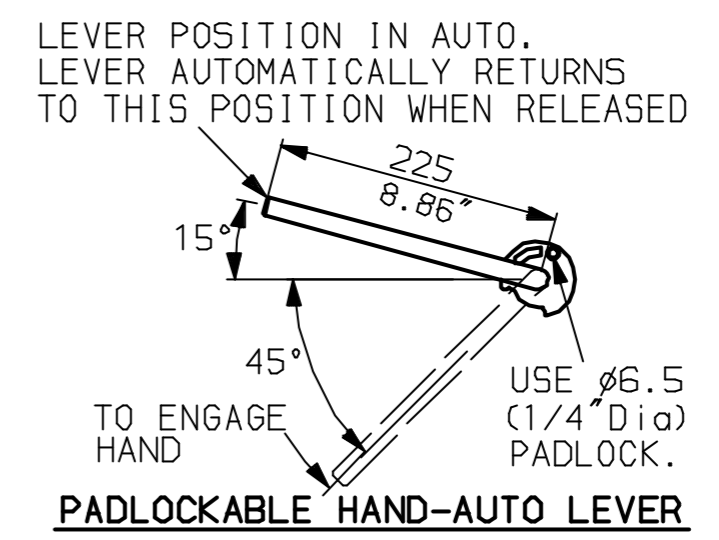
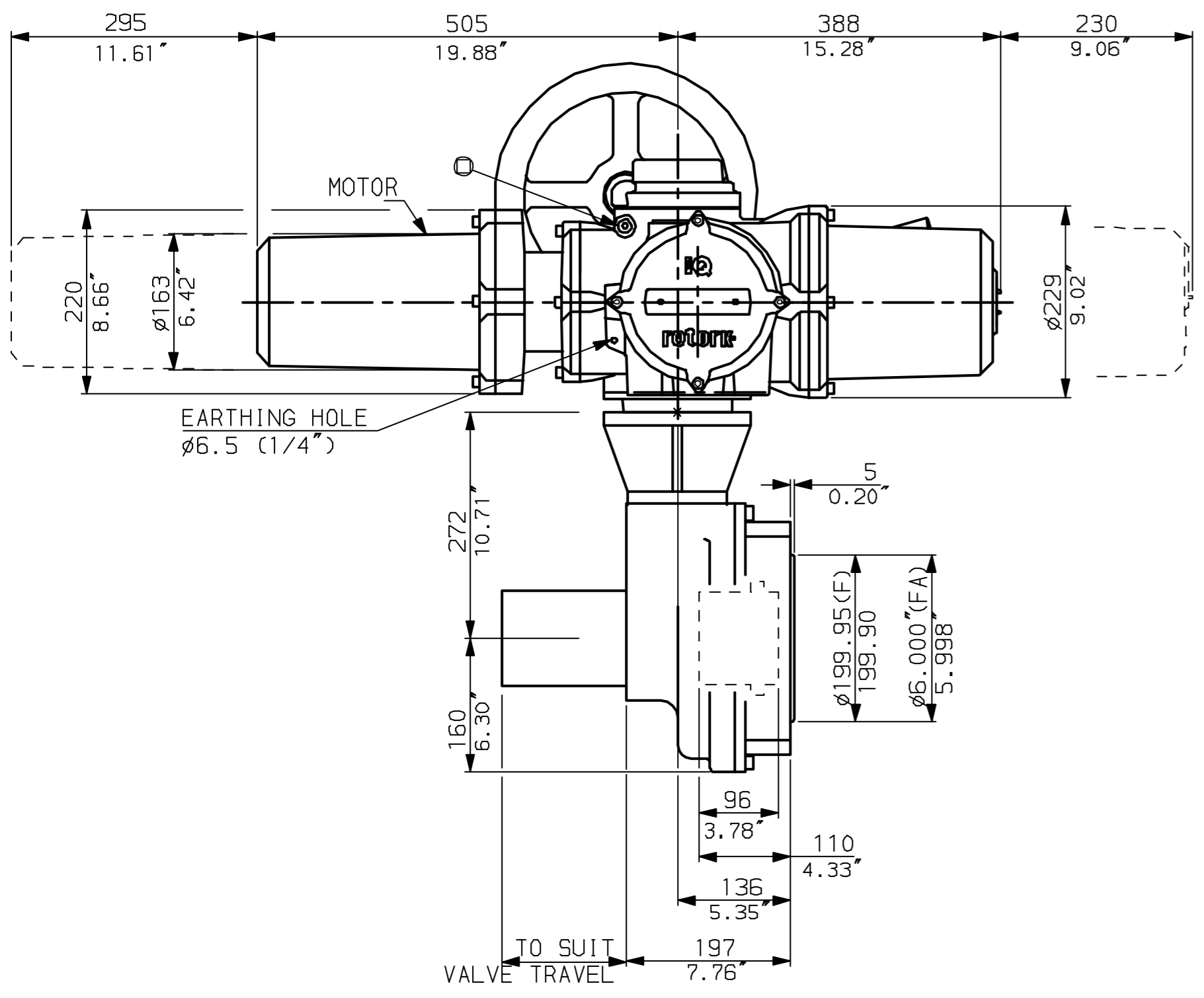
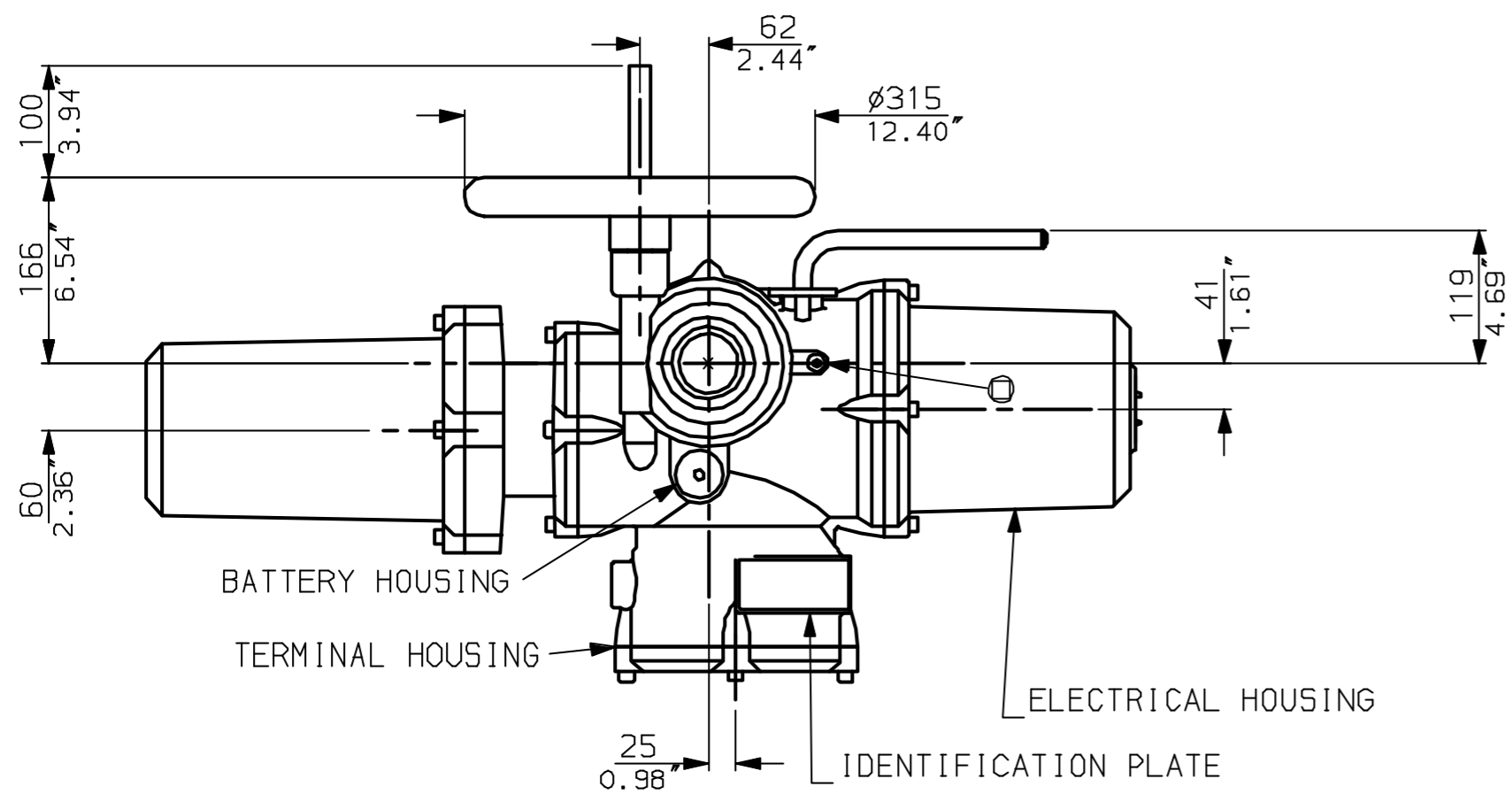

NOTES:
 * DIMENSIONS WITH '*' INDICATE COVER REMOVAL ALLOWANCE
 : NETT WEIGHT = 135kg (297lbs)
 : ϕ = OIL FILLER/DRAIN PLUG
 : THE INTERFACE PROVIDED FOR MOUNTING THE ACTUATOR OR SECOND STAGE GEARBOX ONTO THE VALVE SHOULD CONFORM TO GOOD ENGINEERING PRACTICES, ENSURING ADEQUATELY TOLERANCED LIMITS FOR PARALLELISM, PERPENDICULARITY AND CONCENTRICITY.

CONDUIT ENTRIES (N.T.S)

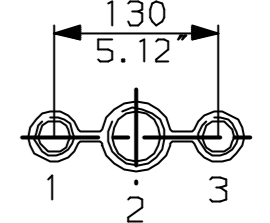

Nos.1 & 3 TAPPED 1" NPT
 No.2 TAPPED 1 1/2" NPT
 STD ALTERNATIVES IF SPECIFIED
 2 X M25, 1 X M40
 2 X PG16, 1 X PG29

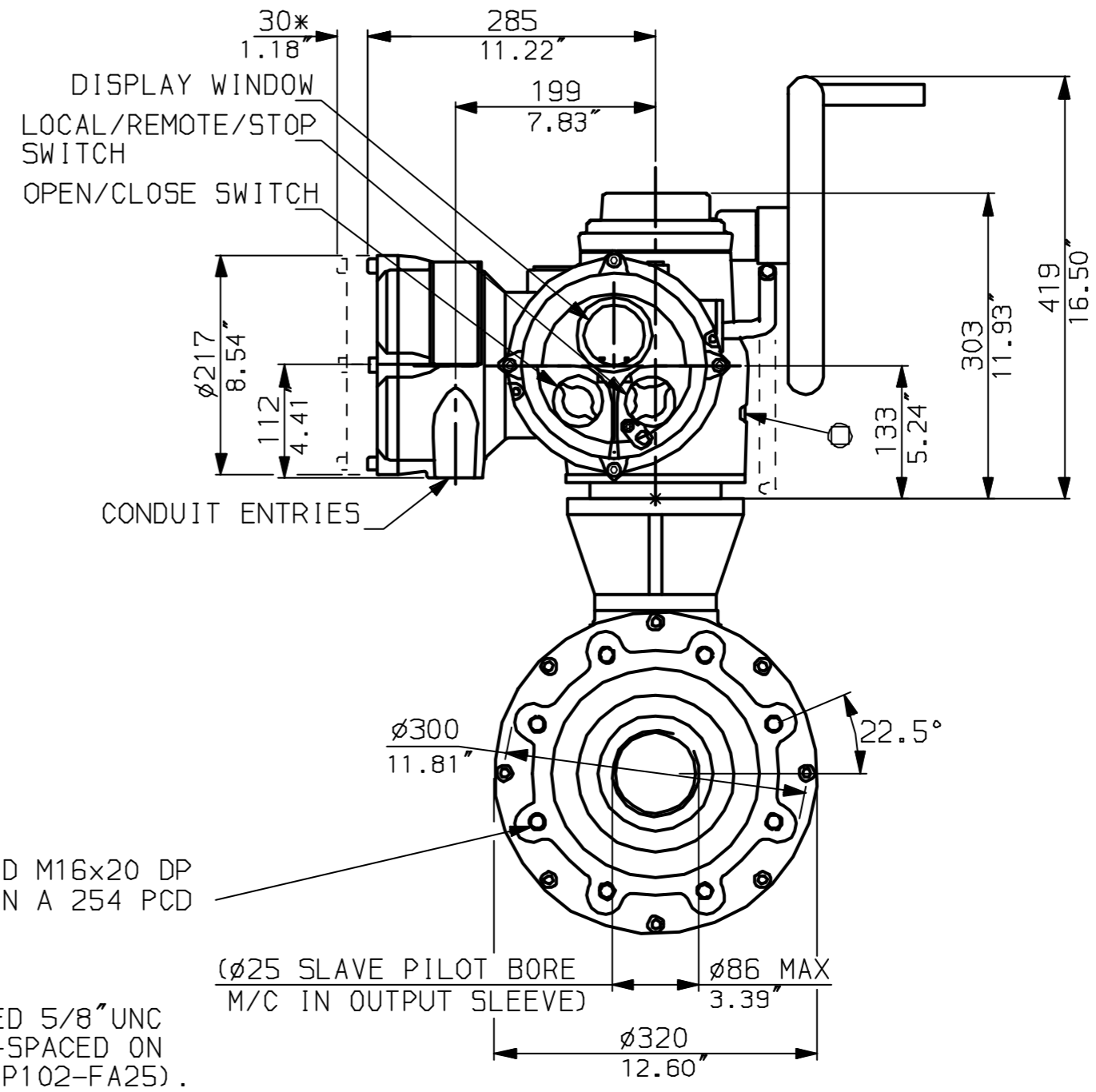

"F" version
 8 HOLES TAPPED M16x20 DP EQUI-SPACED ON A 254 PCD (I505210 F25)

"FA" version
 8 HOLES TAPPED 5/8" UNC x 0.8" dp EQUI-SPACED ON 10" PCD (MSS SP102-FA25).

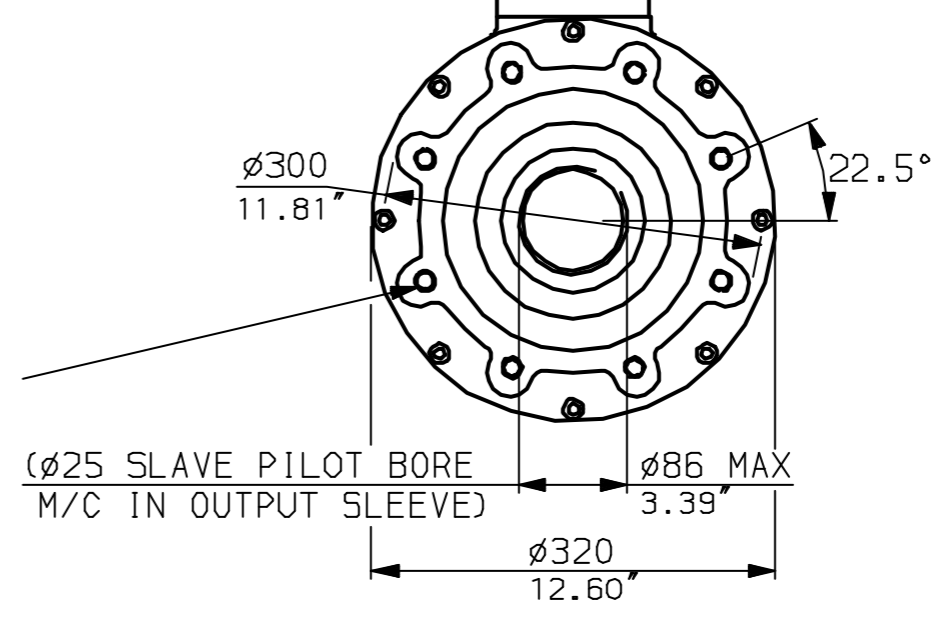

Rotork Controls Ltd.
 Bath England, BA1 3JQ.
 (Phone 01225-733200)

Rotork Controls Inc.
 Rochester, NY 14624
 (Phone 585-328-1550)

Title IQD25, SHW, IB9,		
STANDARD DIMENSIONAL DATA		
Drawn CAD	Checked PRE	Ref Data Sheet
Date April 04	Job No	IQD25SHW_IB9

01	First Issue.
Scale	1:6 THIRD ANGLE PROJECTION
Drawing Number	IQD25SHW_IB9

1 | 2 | 3 | 4 | 5 | 6 | 7 | 8 | 9 | 10