

FOR TYPICAL REMOTE CONTROL DETAILS, SEE DOCUMENT **RWS100**

TRANSFORMER TAPPING OPTIONS		
Tap	Nominal 50/60Hz	FUSE FS1
VOLTAGE	50HZ/60HZ	
LOW	115	500mA
HIGH	230	250mA
FUSE FS1 TO BE ANTI SURGE		
CAPACITOR START/RUN (CS/CS2 AND CR/CR2) COMBINATIONS & VALUES VARY WITH SUPPLY VOLTAGE & ACTUATOR SIZE.		

REFER TO SHEET 2 FOR NOTES & OPTION PCB'S IF FITTED

TORQUE SENSOR

POSITION SENSOR 10 WAY

BATTERY -

FS2 (IF FITTED) 100mA +

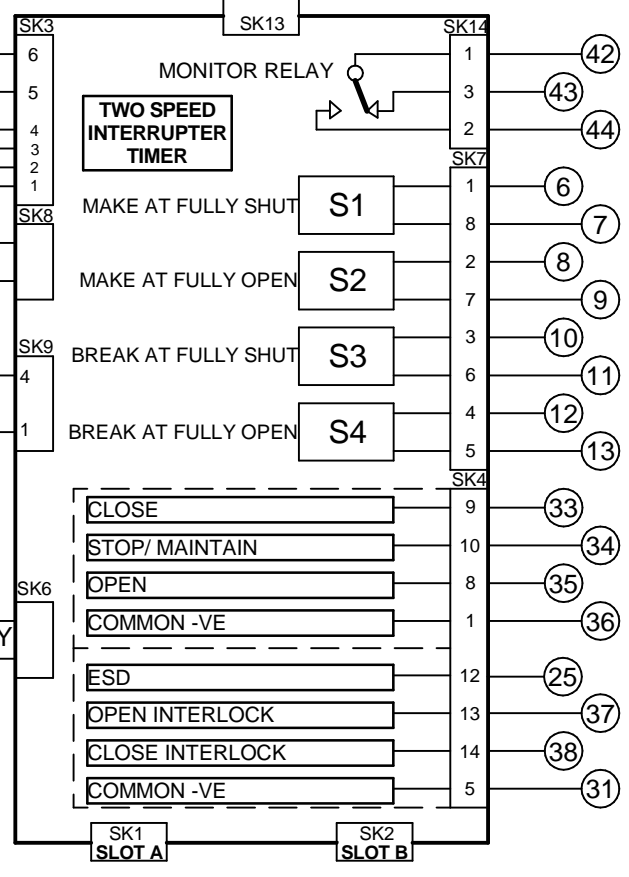
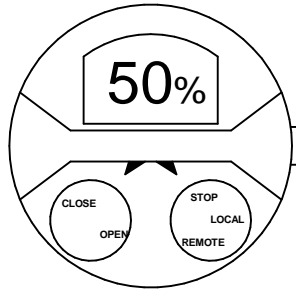

Iss	Date	Chkd	Revision Details
1	160514	PJW	FIRST ISSUE.
2	180614	MR	Note 1 added to sheet 2
3	160915	VGB	PUB091-004 was PUB091-003
4	270116	TH	Updated modbus note

[www.rotork.com](http://www.rotork.com)

ROTORK CONTROLS LTD BATH, BA1 3JQ ENGLAND Tel:01225-733200

ROTORK CONTROLS INC ROCHESTER NY 14624, USA Tel:585-247-2304

IQ SINGLE PHASE + CPT + MODBUS + TIMER

Drawn by: JC1  
Date : 160514  
Base WD: 121M2001  
Job No : --  
MI No : --

Circuit Diagram Number				Issue No	Sheet
<b>121M2001</b>				<b>4</b>	<b>1</b>
B1	C1	B2	C2		

## SLOT A

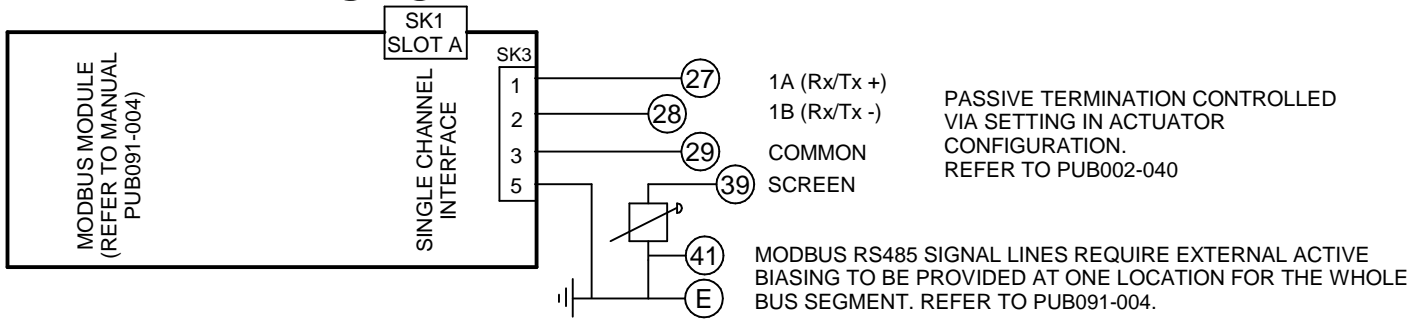

## SLOT B

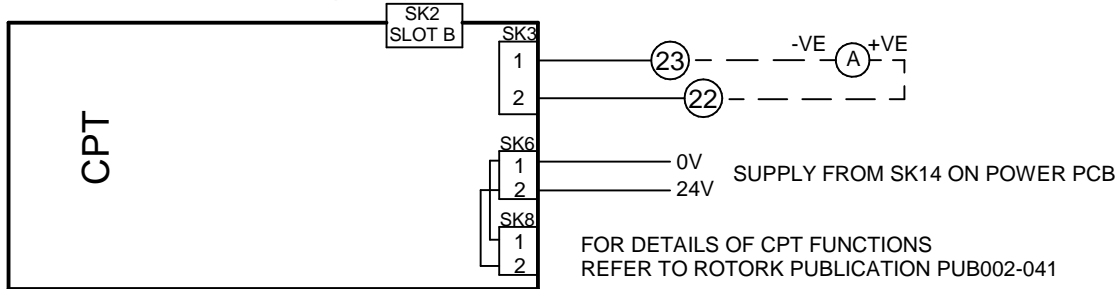

### NOTES

#### 1.FUSES:

- PS1 is a self-resetting fuse.
- Refer to publication PUB002-039 for approved fuses FS1 and FS2.
- Actuator rated voltage specified on nameplate. Voltage tolerance +/-10%, applies for rated torque performance; duty cycle is not guaranteed.

#### 2.REMOTE CONTROL:

- For typical remote control circuits refer to:
  - RWS indicated or PUB002-041.
- For DC and AC control, connect -ve/0V to terminal 36.
- (For negative switch / positive common, refer to RWS indicated).
- Control signal threshold voltages:
  - DC: "on" ≥16Vdc / "off" ≤8Vdc, max 60Vdc.
  - AC: "on" ≥60Vac / "off" ≤40Vac, max 120Vac.
- Control signal duration to be 300ms minimum.
- Maximum current drawn from remote control signals is:
  - 8mA at 24Vdc or 12mA at 120Vac.
- Supply provided on terminals 4 & 5:
  - Intended for remote control.
  - Max external load 5W at 24Vdc / 5VA at 120Vac

#### 3.INDICATION:

- For typical position, status and alarm indication see PUB002-041.
- “S” contacts are user configurable and are shown in their default setting.
- Refer to PUB002-040 for functions and configuration instructions.
- Monitor Relay indicates actuator availability for remote control (shown “unavailable”). It can be configured to exclude local/remote selection.
- Refer to PUB002-040 for monitored functions and configuration instructions.
- Voltage applied to indication contacts must not exceed 150Vac
- Individual Switch current must not exceed 3.5A inductive, 5A resistive and no more than 8A in total for all 4 contacts.

#### 4.BATTERY:

- Battery maintains local and remote “S” contact indication only.
- Refer to installation manual for approved replacement battery types.