

NOTES:
 :DIMENSIONS WITH '*' INDICATE COVER REMOVAL ALLOWANCE
 :NETT WEIGHT = 43kg (95lbs)
 : = OIL FILLER/DRAIN PLUG
 :THE INTERFACE PROVIDED FOR MOUNTING THE ACTUATOR OR SECOND STAGE GEARBOX ONTO THE VALVE SHOULD CONFORM TO GOOD ENGINEERING PRACTICES, ENSURING ADEQUATELY TOLERANCED LIMITS FOR PARALLELISM, PERPENDICULARITY AND CONCENTRICITY.

CONDUIT ENTRIES (N.T.S)

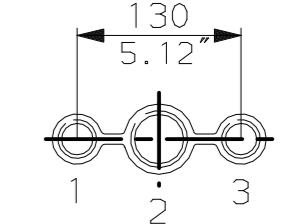

Nos.1 & 3 TAPPED 1" NPT
 No.2 TAPPED 1 1/2" NPT
 STD ALTERNATIVES IF SPECIFIED
 2 X M25, 1 X M40
 2 X PG16, 1 X PG29

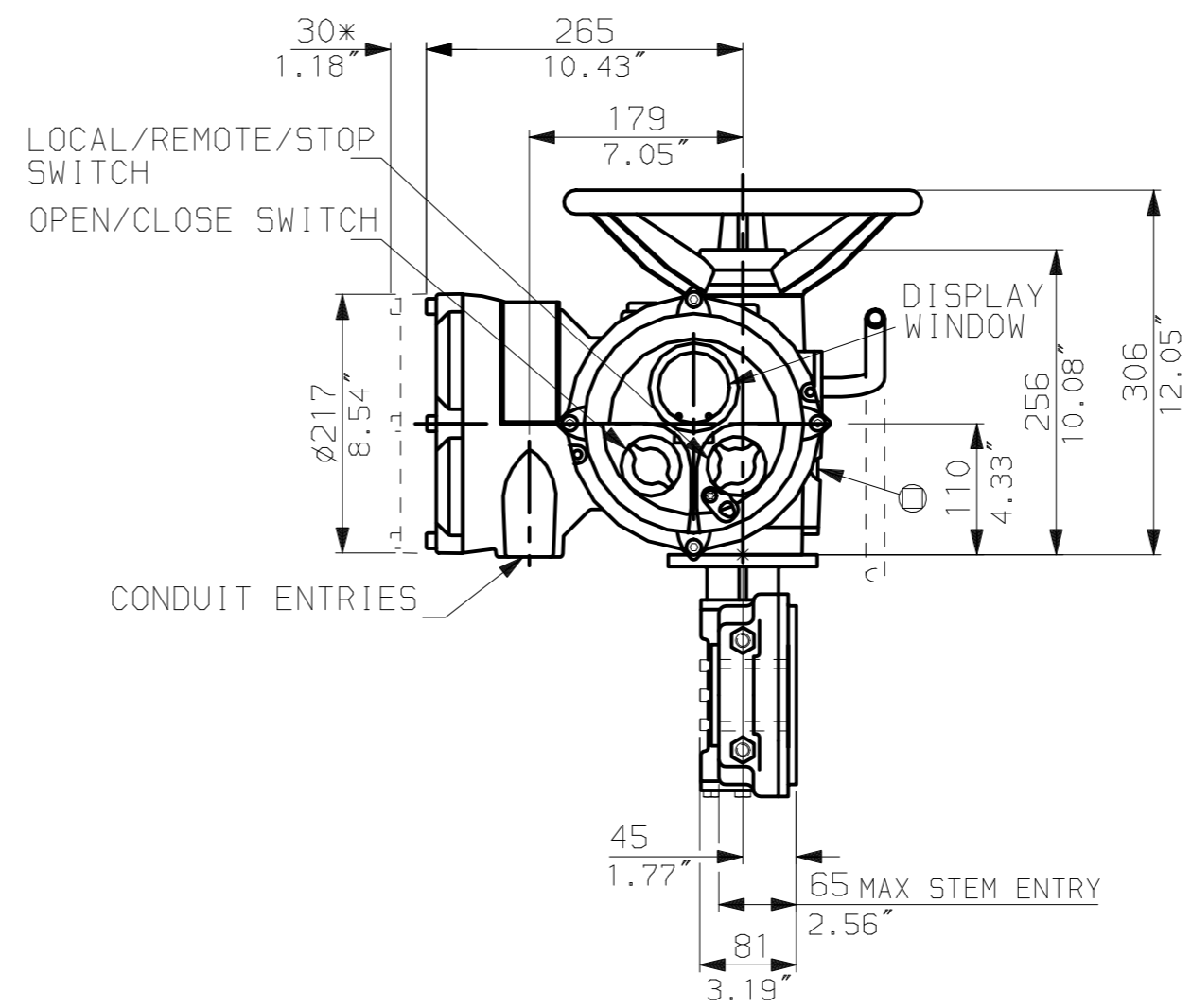
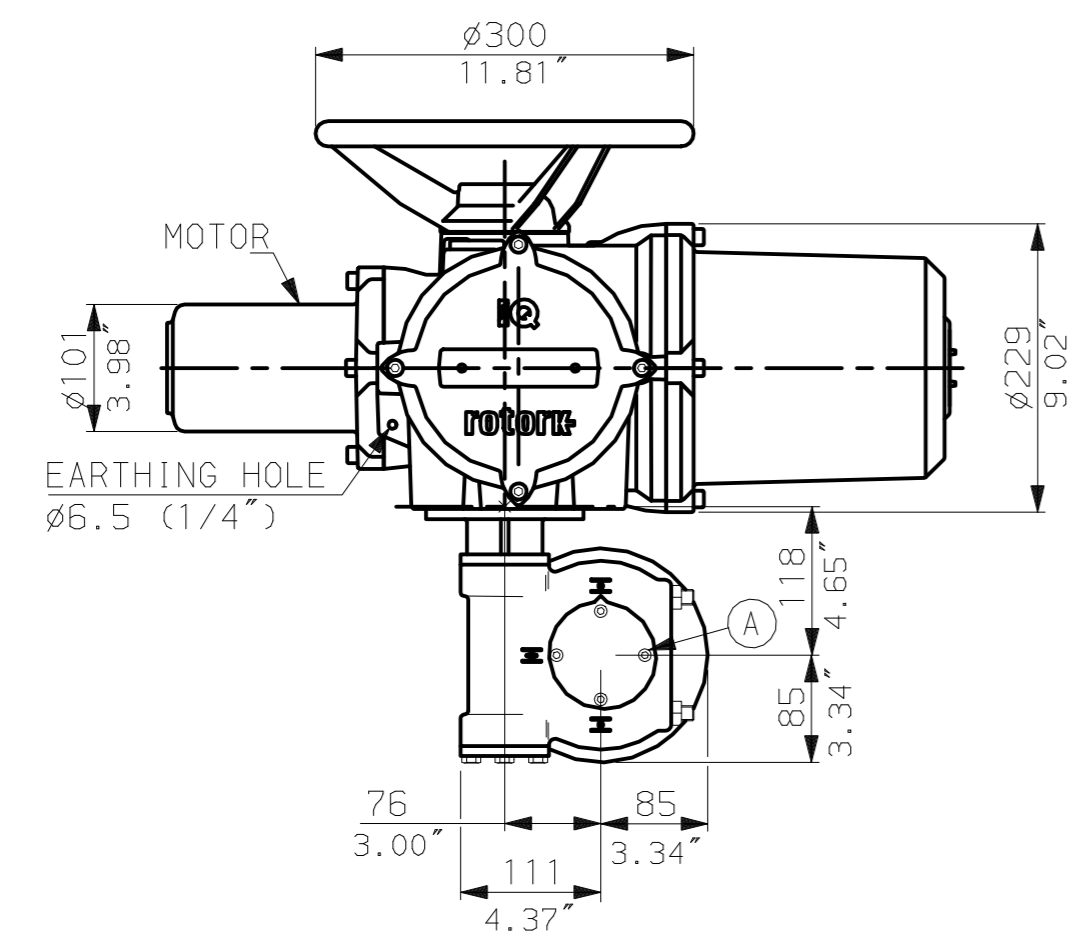

N.B. KEYWAY POS. CAN BE MOVED 90 OR 180° BY REMOVING 4 SCREWS MARKED (A) AND ROTATING OUTPUT SLEEVE.

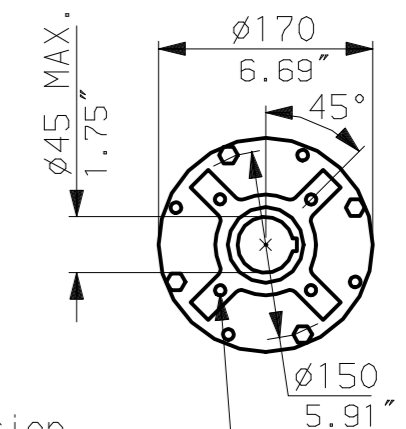

"F" version
 4 HOLES TAPPED M10 x 18 DP
 EQUI-SPACED AS SHOWN ON A
 102 PCD (150 5211-F10).

"FA" version
 4 HOLES TAPPED 3/8" UNC x 0.7" dp
 EQUI-SPACED AS SHOWN ON A
 4" PCD (M55 SP101-FA10).



Rotork Controls Ltd.
 Bath England, BA1 3JQ.
 (Phone 01225-733200)
 Rotork Controls Inc.
 Rochester, NY 14624
 (Phone 585-328-1550)

Title IQ10, 12, 18, (+IQS12), THW, IW3,		
STANDARD DIMENSIONAL DATA		
Drawn CAD	Checked PRE	Ref Data Sheet
Date 150605	Job No IQ1THW_IW3	

02	4.69" corrected from 6.50"
01 Issue	First Issue.
Scale	1:6 THIRD ANGLE PROJECTION
Drawing Number	IQ1THW_IW3

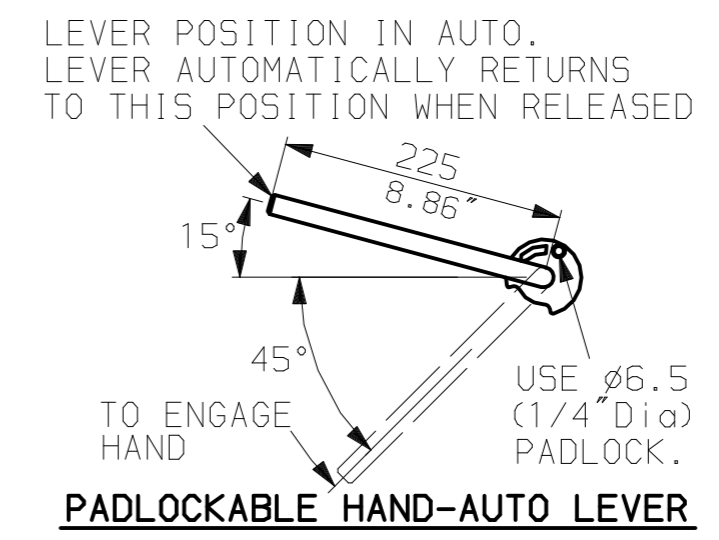
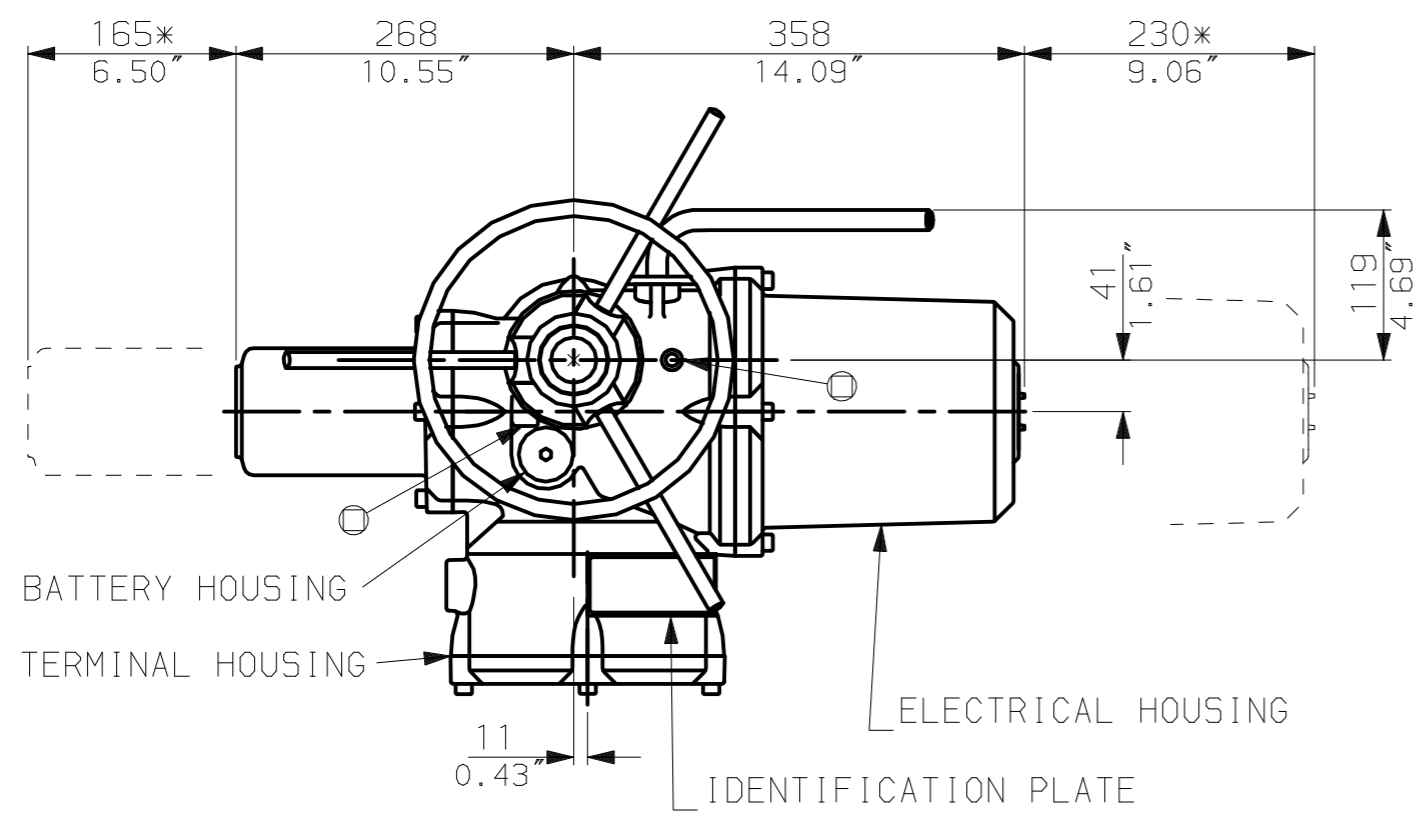

NOTES:
: DIMENSIONS WITH '*' INDICATE COVER REMOVAL ALLOWANCE
: NETT WEIGHT = 43kg (95lbs)
: \odot = OIL FILLER/DRAIN PLUG
: THE INTERFACE PROVIDED FOR MOUNTING THE ACTUATOR OR SECOND STAGE GEARBOX ONTO THE VALVE SHOULD CONFORM TO GOOD ENGINEERING PRACTICES, ENSURING ADEQUATELY TOLERANCED LIMITS FOR PARALLELISM, PERPENDICULARITY AND CONCENTRICITY.

CONDUIT ENTRIES (N.T.S)

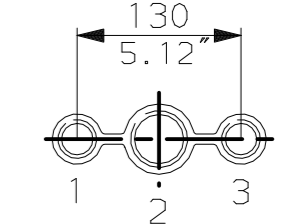

Nos.1 & 3 TAPPED 1" NPT
No.2 TAPPED 1 1/2" NPT
STD ALTERNATIVES IF SPECIFIED
2 X M25, 1 X M40
2 X PG16, 1 X PG29

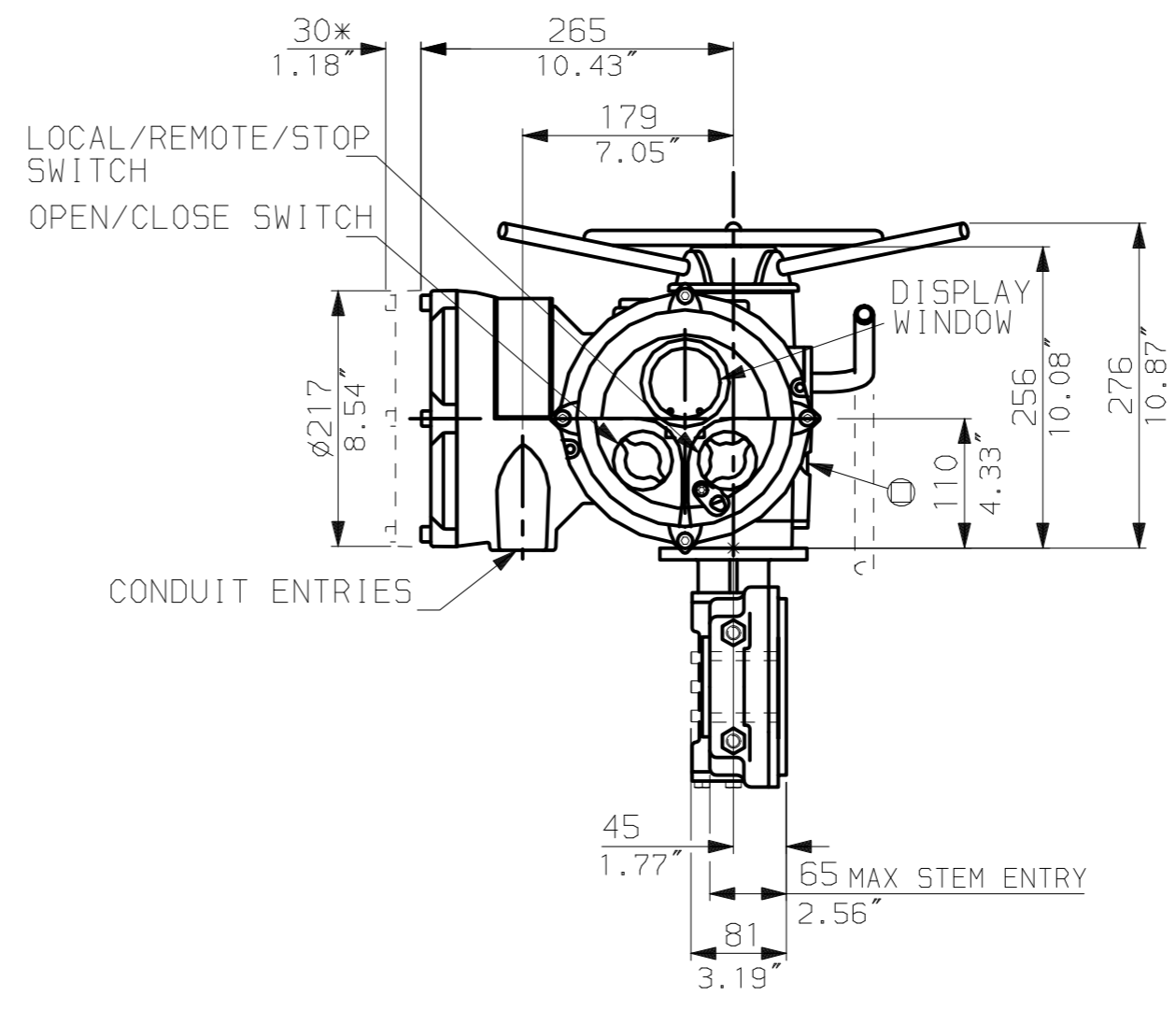
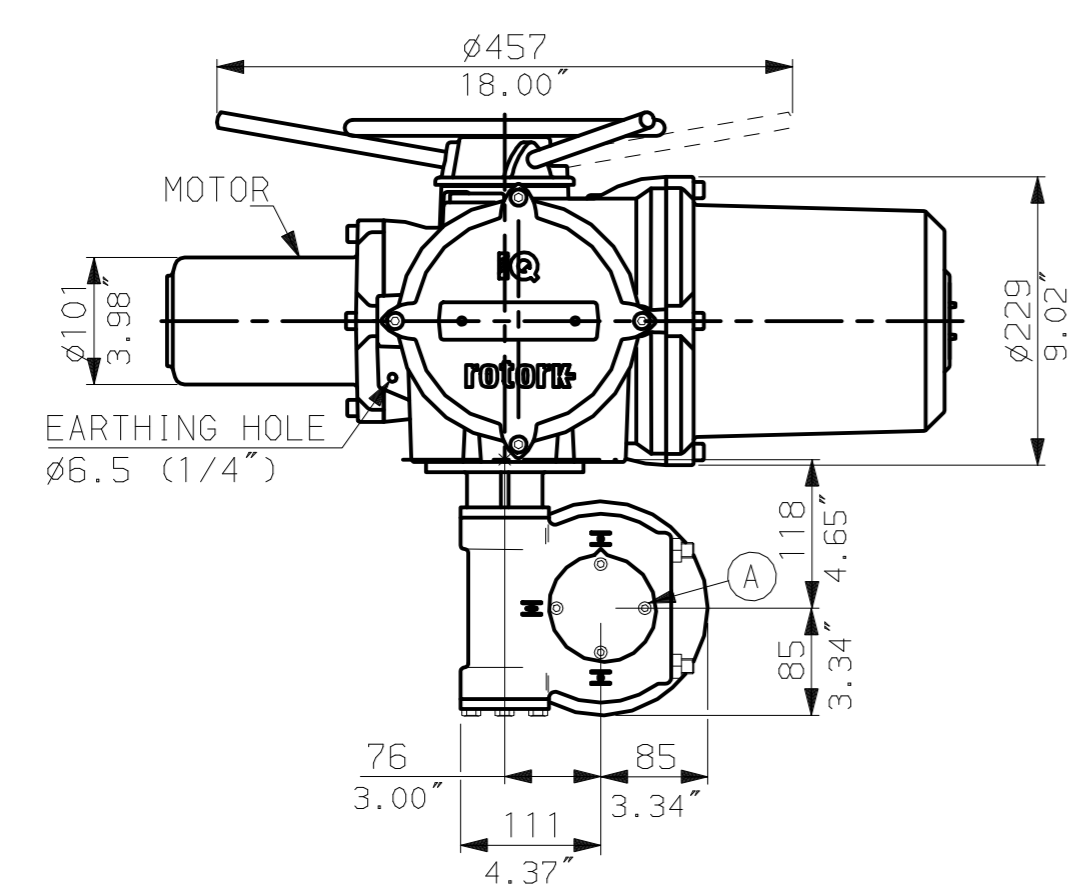

N.B. KEYWAY POS. CAN BE MOVED 90 OR 180° BY REMOVING 4 SCREWS MARKED (A) AND ROTATING OUTPUT SLEEVE.

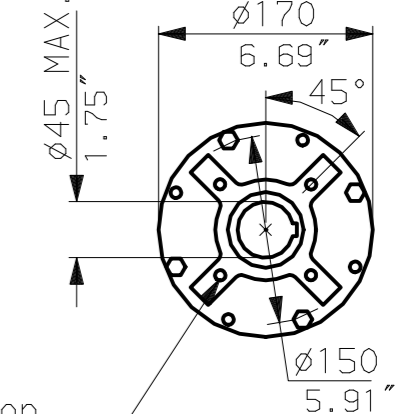

"F" version

4 HOLES TAPPED M10 x 18 DP
EQUI-SPACED AS SHOWN ON A
102 PCD (ISO 5211-F10).

"FA" version

4 HOLES TAPPED 3/8" UNC x 0.7" dp
EQUI-SPACED AS SHOWN ON A
4" PCD (M55 SP101-FA10).



Rotork Controls Ltd.
Bath England, BA1 3JQ.
(Phone 01225-733200)

Rotork Controls Inc.
Rochester, NY 14624
(Phone 585-328-1550)

Title IQ10, 12, 18, (+IQS12), LTHW, IW3,		
STANDARD DIMENSIONAL DATA		
Drawn CAD	Checked PRE	Ref Data Sheet
Date 150605	Job No IQ1LTHW_IW3	

02	4.69" corrected from 6.50"
01 Issue	First Issue.
Scale	1:6 THIRD ANGLE PROJECTION
Drawing Number	IQ1LTHW_IW3

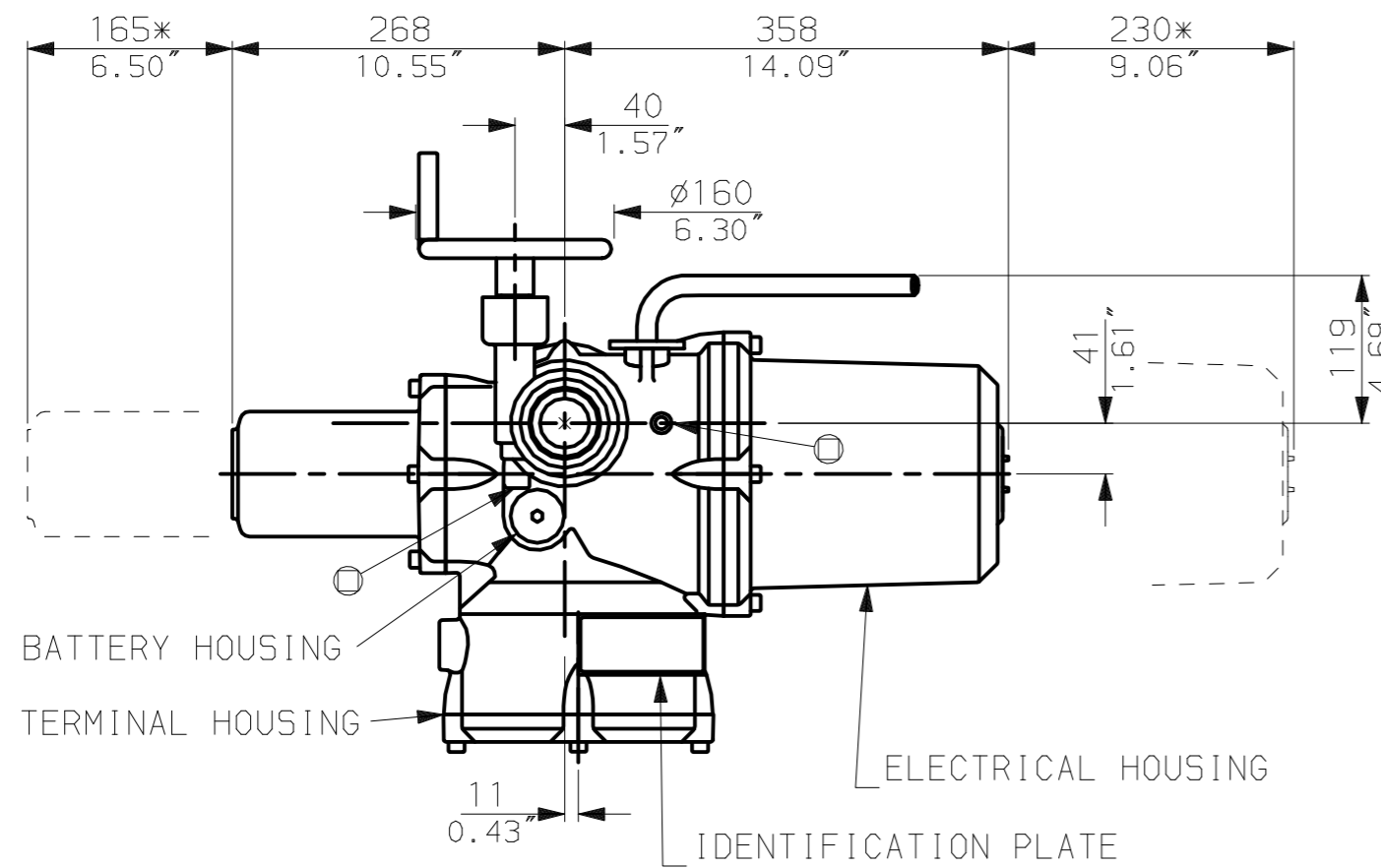

LEVER POSITION IN AUTO.
LEVER AUTOMATICALLY RETURNS
TO THIS POSITION WHEN RELEASED

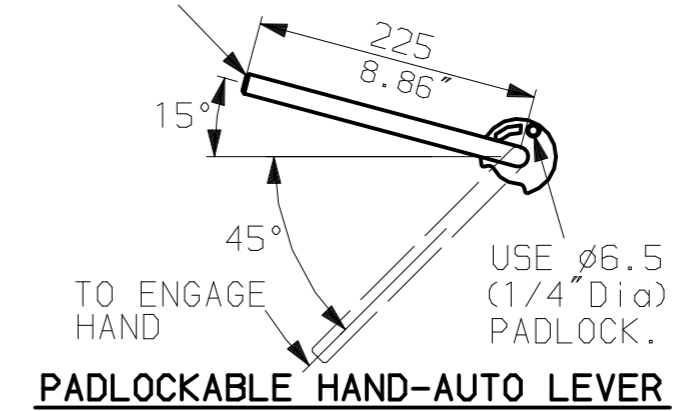

NOTES:
: DIMENSIONS WITH '*' INDICATE COVER REMOVAL ALLOWANCE
: NETT WEIGHT = 43kg (95lbs)
: \odot = OIL FILLER/DRAIN PLUG
: THE INTERFACE PROVIDED FOR MOUNTING THE ACTUATOR OR SECOND STAGE GEARBOX ONTO THE VALVE SHOULD CONFORM TO GOOD ENGINEERING PRACTICES, ENSURING ADEQUATELY TOLERANCED LIMITS FOR PARALLELISM, PERPENDICULARITY AND CONCENTRICITY.

CONDUIT ENTRIES (N.T.S)

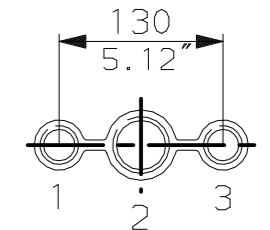

Nos.1 & 3 TAPPED 1" NPT
No.2 TAPPED 1 1/2" NPT
STD ALTERNATIVES IF SPECIFIED
2 X M25, 1 X M40
2 X PG16, 1 X PG29

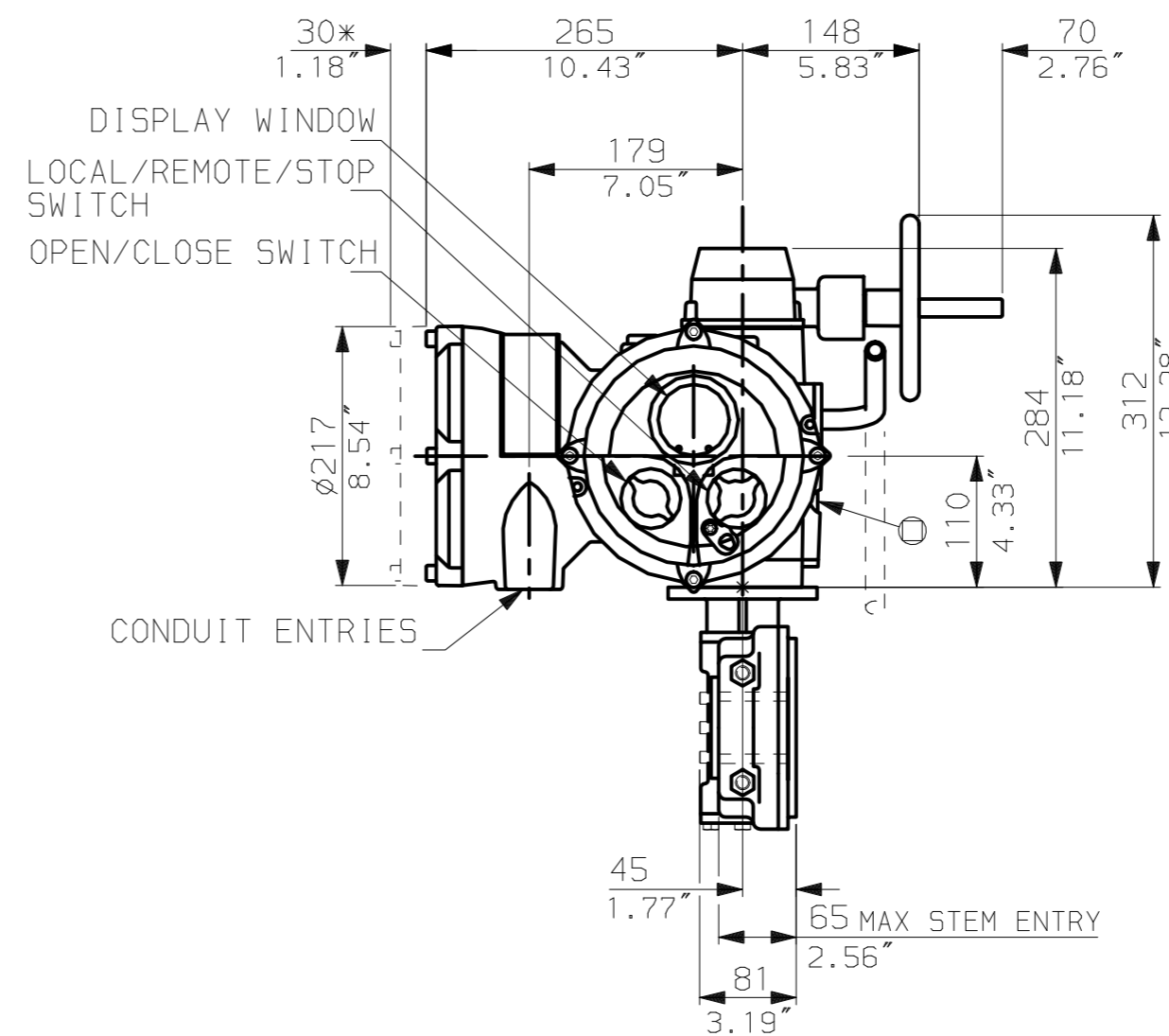
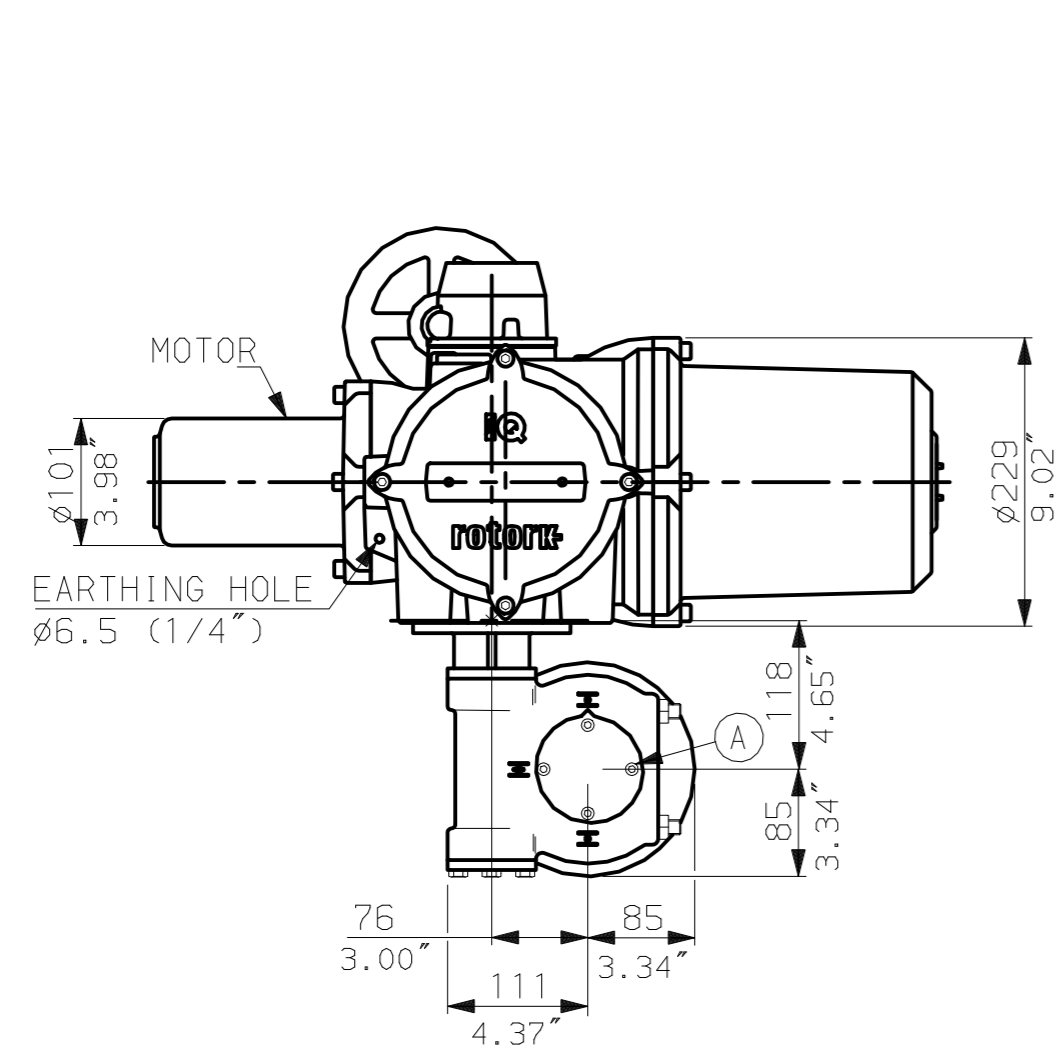

N.B. KEYWAY POS. CAN BE MOVED 90 OR 180° BY REMOVING 4 SCREWS MARKED (A) AND ROTATING OUTPUT SLEEVE.

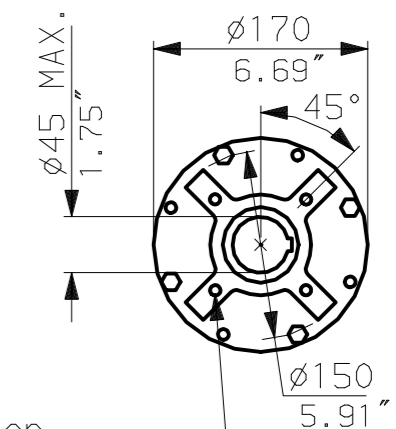

"F" version

4 HOLES TAPPED M10 x 18 DP
EQUI-SPACED AS SHOWN ON A
102 PCD (150 5211-F10).

"FA" version

4 HOLES TAPPED 3/8" UNC x 0.7" dp
EQUI-SPACED AS SHOWN ON A
4" PCD (MSS SP101-FA10).

rotork
www.rotork.com

Rotork Controls Ltd.
Bath England, BA1 3JQ.
(Phone 01225-733200)
Rotork Controls Inc.
Rochester, NY 14624
(Phone 585-328-1550)

Title IQ10, 12, 18, (+IQS12), SHW, IW3,		
STANDARD DIMENSIONAL DATA		
Drawn CAD	Checked PRE	Ref Data Sheet
Date 150605	Job No IQ1SHW_IW3	

02	4.69" corrected from 6.50"
01	First Issue.
Issue	
Scale	1:6 THIRD ANGLE PROJECTION
Drawing Number	IQ1SHW_IW3