

LEVER POSITION IN AUTO.
LEVER AUTOMATICALLY RETURNS
TO THIS POSITION WHEN RELEASED

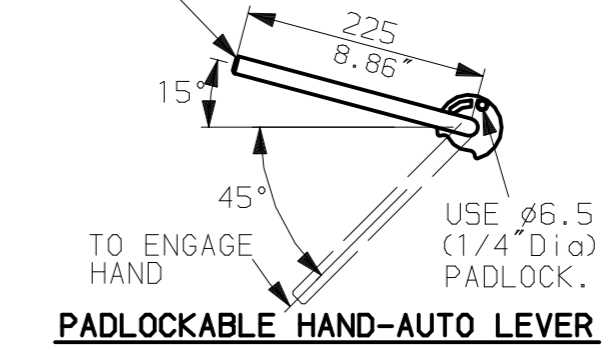

NOTES:
: DIMENSIONS WITH '*' INDICATE COVER REMOVAL ALLOWANCE
: NETT WEIGHT = 184kg (405lbs)
: \odot = OIL FILLER/DRAIN PLUG
: THE INTERFACE PROVIDED FOR MOUNTING THE ACTUATOR OR SECOND STAGE GEARBOX ONTO THE VALVE SHOULD CONFORM TO GOOD ENGINEERING PRACTICES, ENSURING ADEQUATELY TOLERANCED LIMITS FOR PARALLELISM, PERPENDICULARITY AND CONCENTRICITY.

CONDUIT ENTRIES (N.T.S)

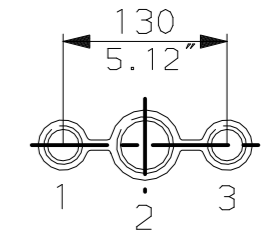

Nos. 1 & 3 TAPPED 1" NPT
No. 2 TAPPED 1 1/2" NPT
STD ALTERNATIVES IF SPECIFIED
2 X M25, 1 X M40
2 X PG16, 1 X PG29

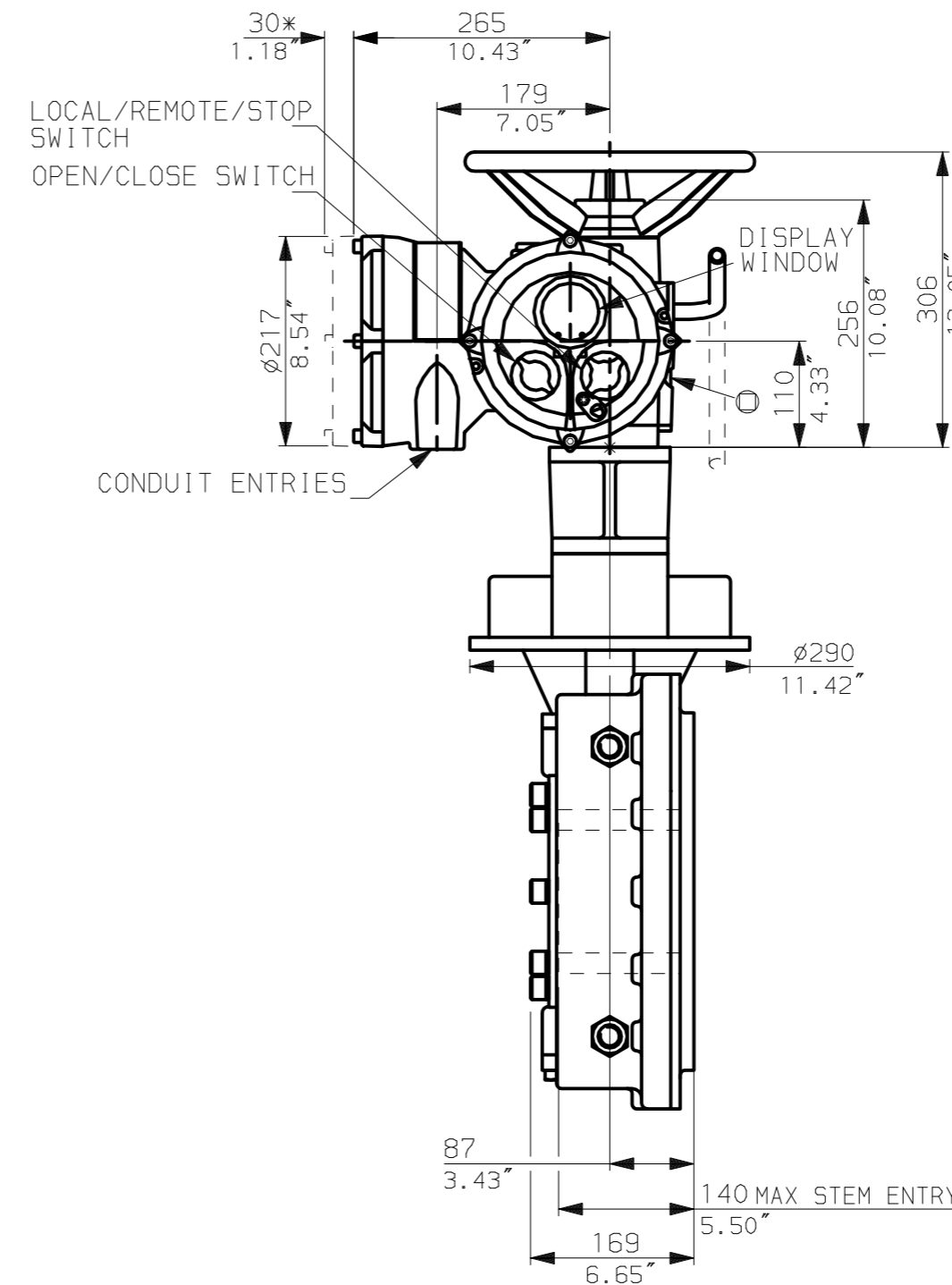
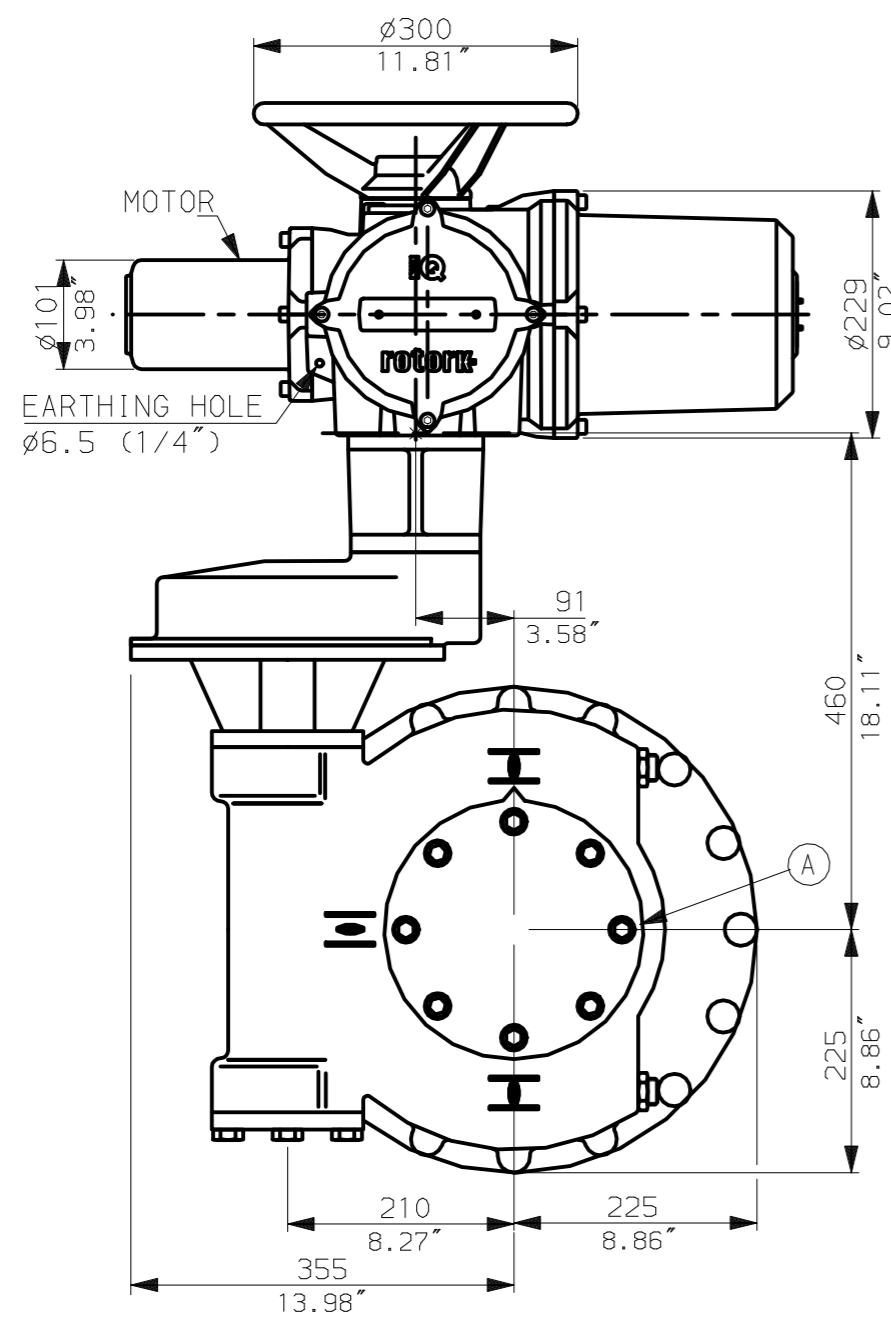

N.B. KEYWAY POS. CAN BE MOVED 90 OR 180° BY REMOVING 8 SCREWS MARKED (A) AND ROTATING OUTPUT SLEEVE.

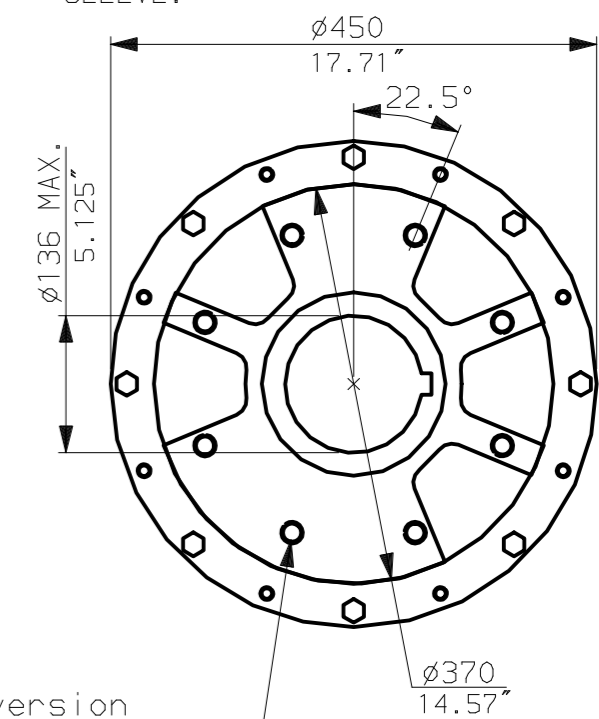

"F" version

8 HOLES TAPPED M20 x 24 DP
EQUI-SPACED AS SHOWN ON A
298 PCD (ISO 5211-F30).

"FA" version

8 HOLES TAPPED 3/4" UNC x 0.94" dp
EQUI-SPACED AS SHOWN ON A
11.75" PCD (MSS SP101-FA30).

NOTE:
Gearbox is shown with LOW Ratio Input Reducer.
(ie Ratios 120, 180, 240, 360)
See Data Sheet with IW7Rh for HIGH ratio option.

rotork
www.rotork.com

Rotork Controls Ltd.
Bath England, BA1 3JQ.
(Phone 01225-733200)
Rotork Controls Inc.
Rochester, NY 14624
(Phone 585-328-1550)

Title IQ10, 12, 18, (+IQS12), THW, IW (MOW) 7 (+72) RL,	
STANDARD DIMENSIONAL DATA	
Drawn CAD	Checked PRE Ref Data Sheet
Date 150605	Job No IQ1THW_IW7RL

02	4.69" corrected from 6.50"
01	First Issue.
Scale	1:7 THIRD ANGLE PROJECTION
Drawing Number	IQ1THW_IW7RL

G
F
E
D
C
B
A

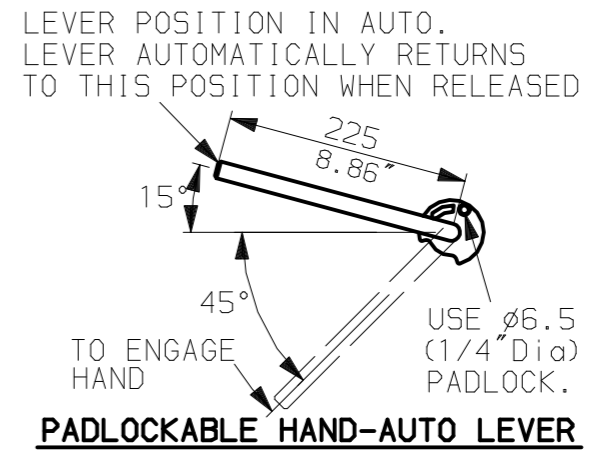
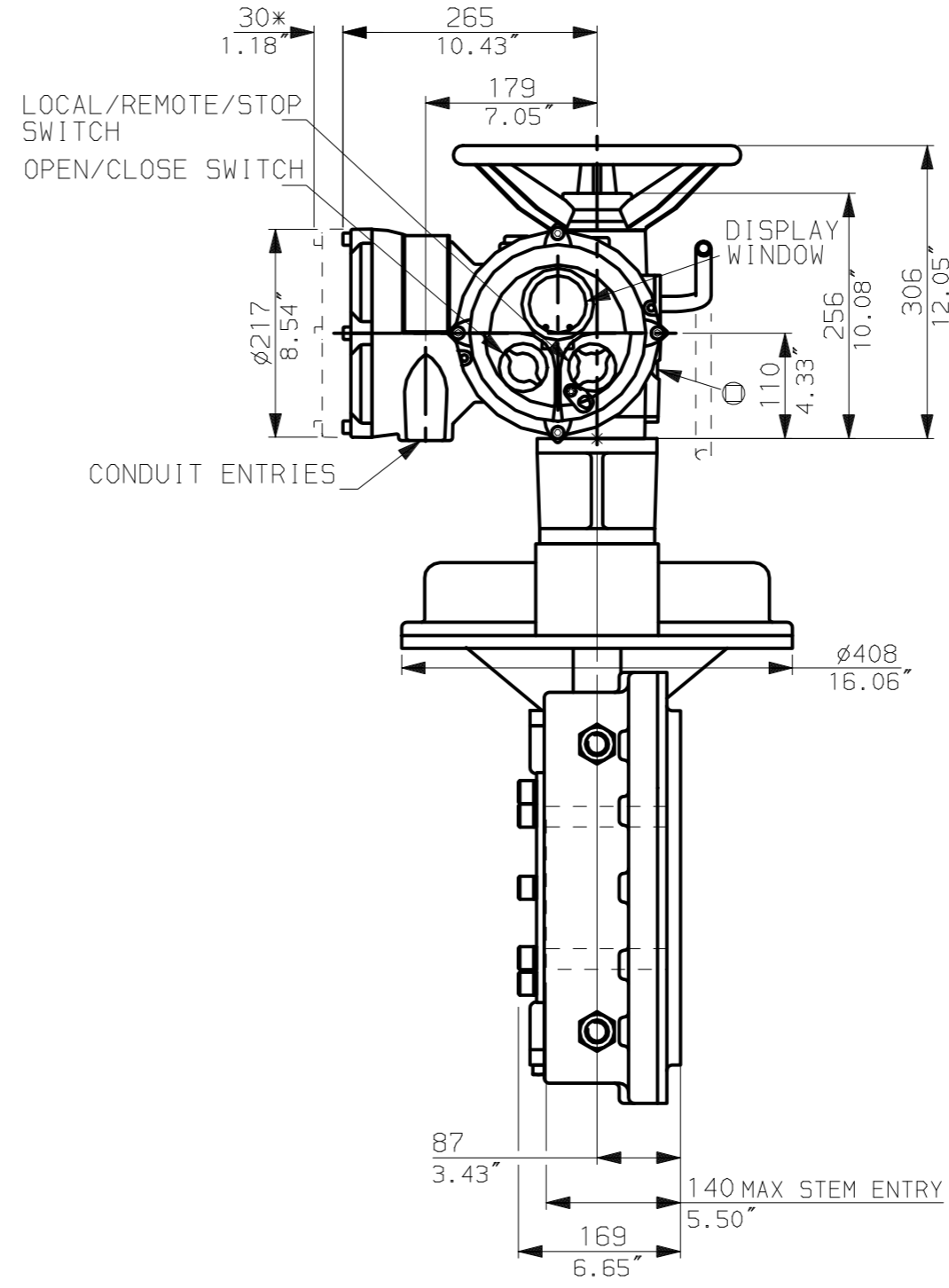
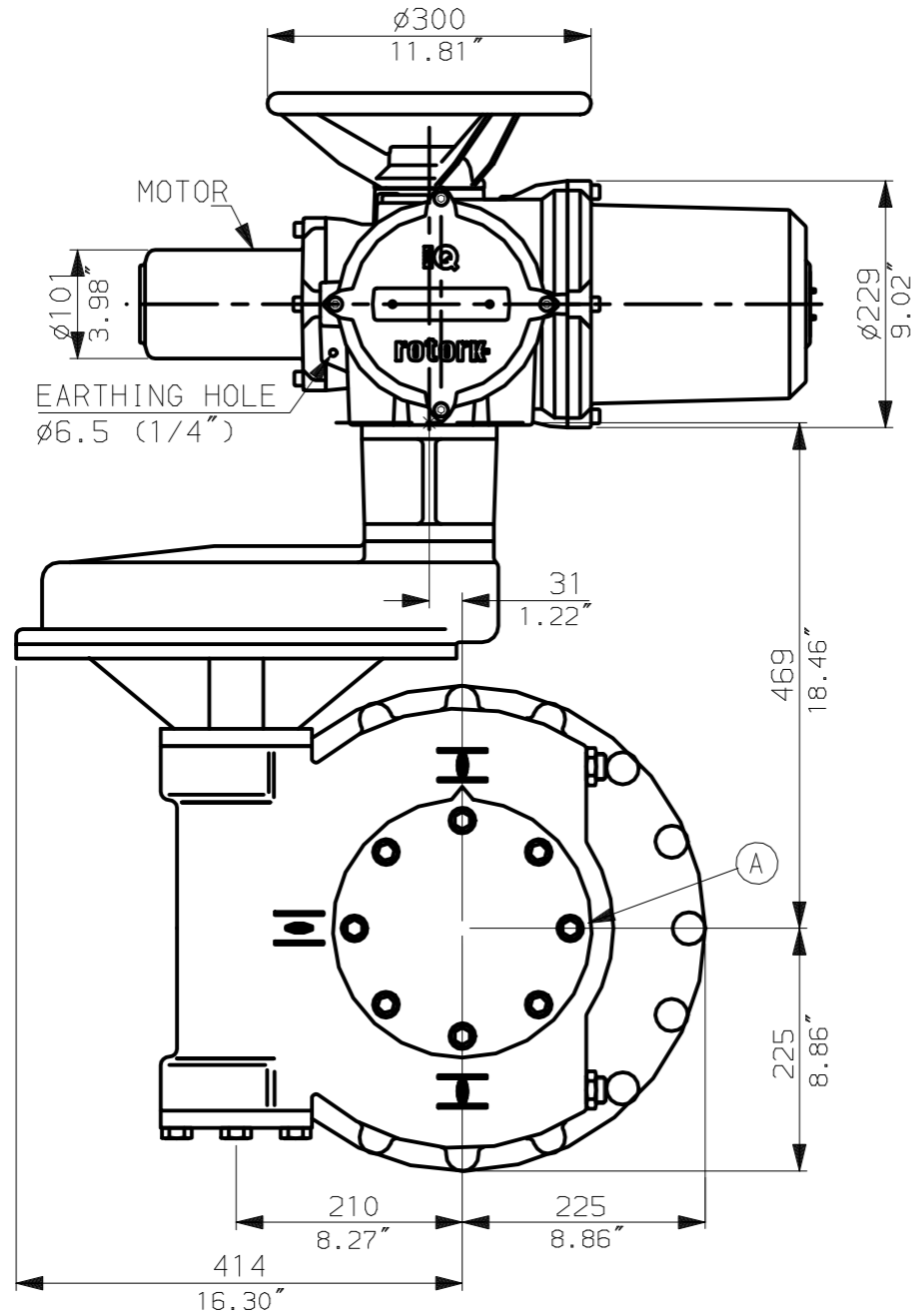
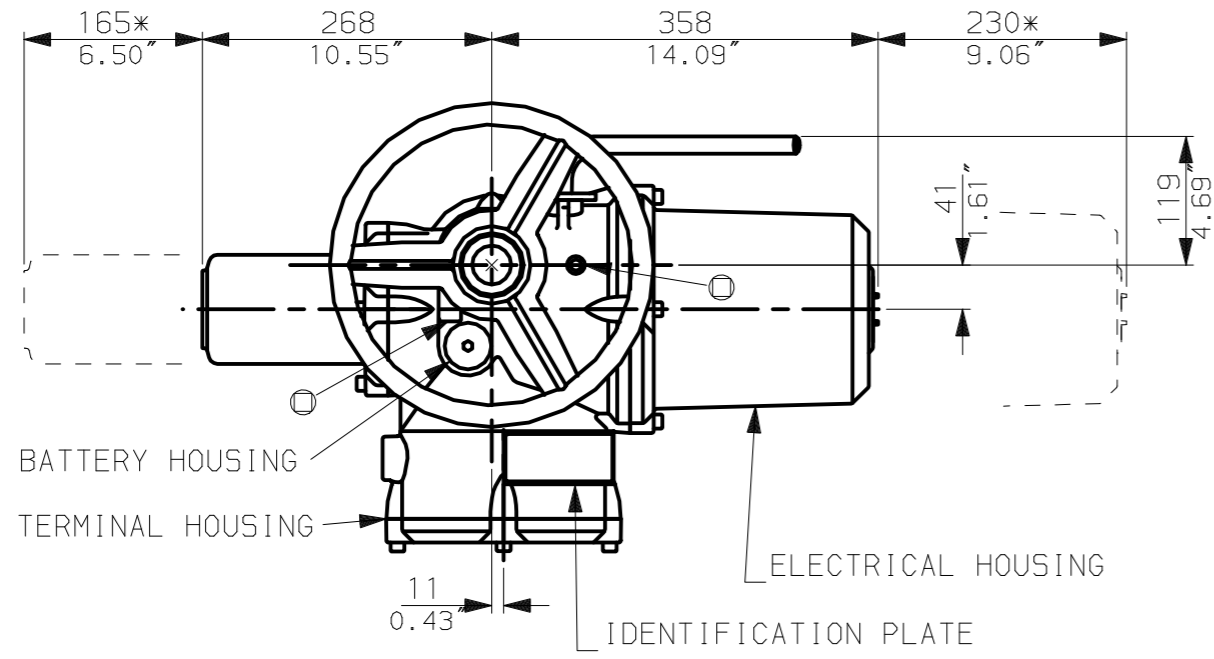

NOTES:
:DIMENSIONS WITH '*' INDICATE COVER REMOVAL ALLOWANCE
:NETT WEIGHT = 194kg (427lbs)
:⊙ = OIL FILLER/DRAIN PLUG
:THE INTERFACE PROVIDED FOR MOUNTING THE ACTUATOR OR SECOND STAGE GEARBOX ONTO THE VALVE SHOULD CONFORM TO GOOD ENGINEERING PRACTICES, ENSURING ADEQUATELY TOLERANCED LIMITS FOR PARALLELISM, PERPENDICULARITY AND CONCENTRICITY.

CONDUIT ENTRIES (N.T.S)

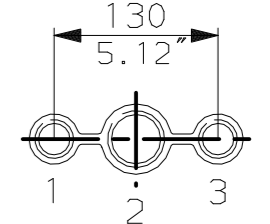

Nos.1 & 3 TAPPED 1" NPT
No.2 TAPPED 1 1/2" NPT
STD ALTERNATIVES IF SPECIFIED
2 X M25, 1 X M40
2 X PG16, 1 X PG29

N.B. KEYWAY POS. CAN BE MOVED 90 OR 180° BY REMOVING 8 SCREWS MARKED (A) AND ROTATING OUTPUT SLEEVE.

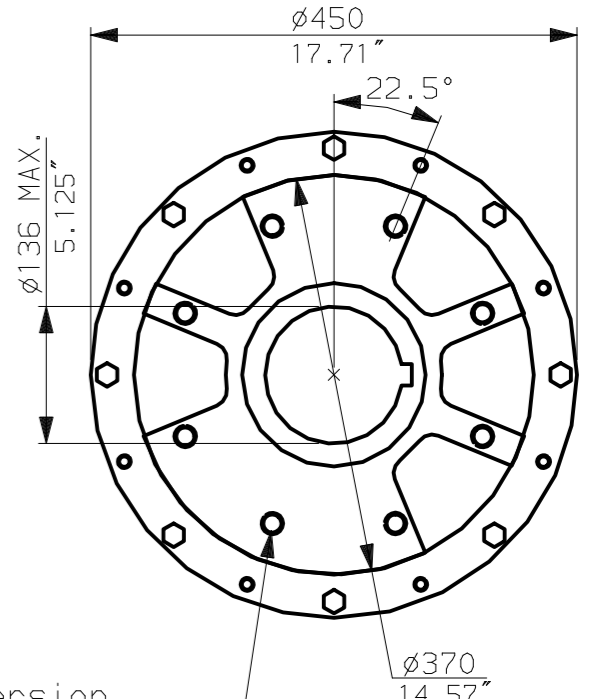

"F" version
8 HOLES TAPPED M20 x 24 DP
EQUI-SPACED AS SHOWN ON A
298 PCD (ISO 5211-F30).

"FA" version
8 HOLES TAPPED 3/4"UNCx0.94"dp
EQUI-SPACED AS SHOWN ON A
11.75" PCD (MSS SP101-FA30).



Rotork Controls Ltd.
Bath England, BA1 3JQ.
(Phone 01225-733200)

Rotork Controls Inc.
Rochester, NY 14624
(Phone 585-328-1550)

Title IQ10, 12, 18, (+IQS12), THW, IW (MOW) 7 (+72)Rh,		
STANDARD DIMENSIONAL DATA		
Drawn CAD	Checked PRE	Ref Data Sheet
Date 150605	Job No	IQ1THW_IW7Rh

NOTE:
Gearbox is shown with HIGH Ratio Input Reducer.
(ie Ratios 480, 540, 720)
See Data Sheet with IW7RL for LOW ratio option.

02	4.69" corrected from 6.50"
01 Issue	First Issue.
Scale	1:7 THIRD ANGLE PROJECTION
Drawing Number	IQ1THW_IW7Rh

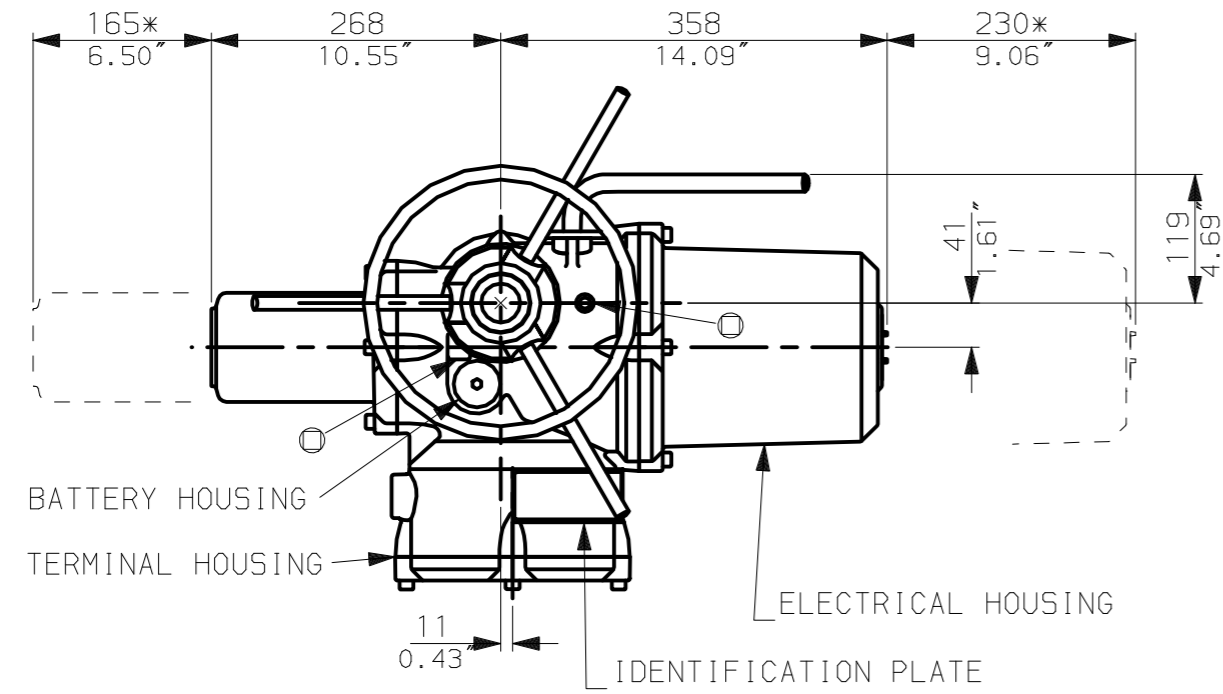

LEVER POSITION IN AUTO.
LEVER AUTOMATICALLY RETURNS
TO THIS POSITION WHEN RELEASED

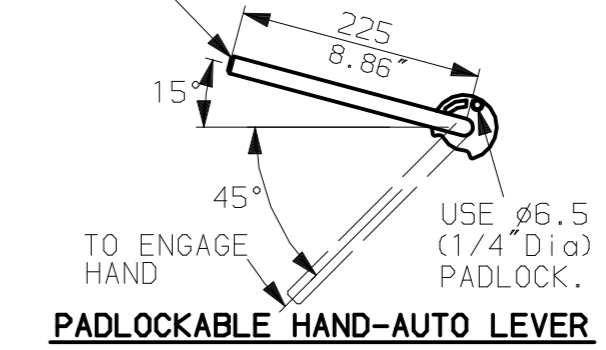

NOTES:
: DIMENSIONS WITH '*' INDICATE COVER REMOVAL ALLOWANCE
: NETT WEIGHT = 184kg (405lbs)
: \odot = OIL FILLER/DRAIN PLUG
: THE INTERFACE PROVIDED FOR MOUNTING THE ACTUATOR OR SECOND STAGE GEARBOX ONTO THE VALVE SHOULD CONFORM TO GOOD ENGINEERING PRACTICES, ENSURING ADEQUATELY TOLERANCED LIMITS FOR PARALLELISM, PERPENDICULARITY AND CONCENTRICITY.

CONDUIT ENTRIES (N.T.S)

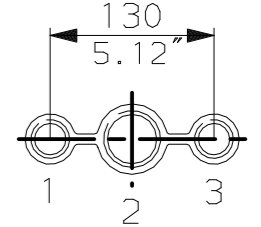

Nos.1 & 3 TAPPED 1" NPT
No.2 TAPPED 1 1/2" NPT
STD ALTERNATIVES IF SPECIFIED
2 X M25, 1 X M40
2 X PG16, 1 X PG29

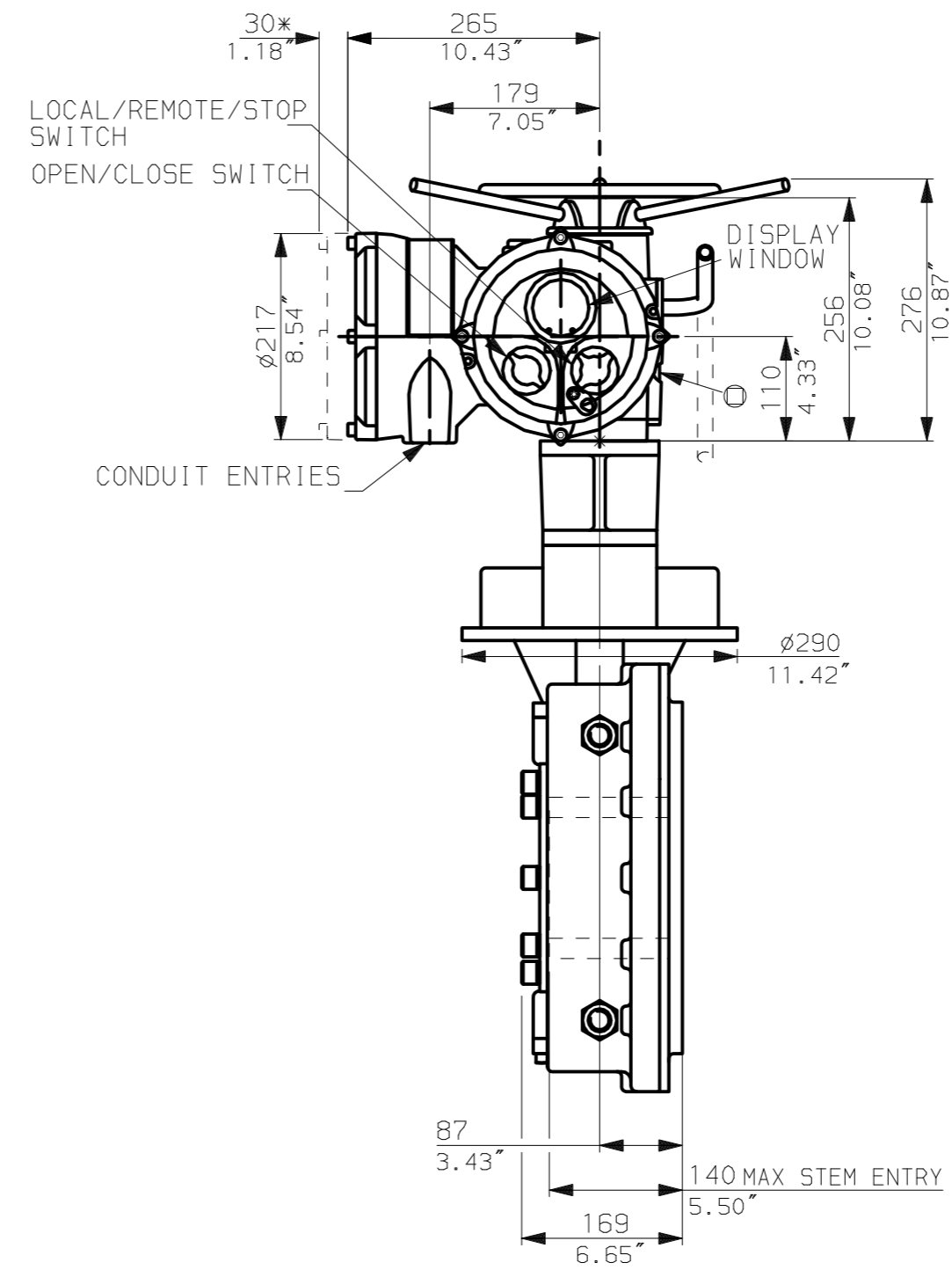
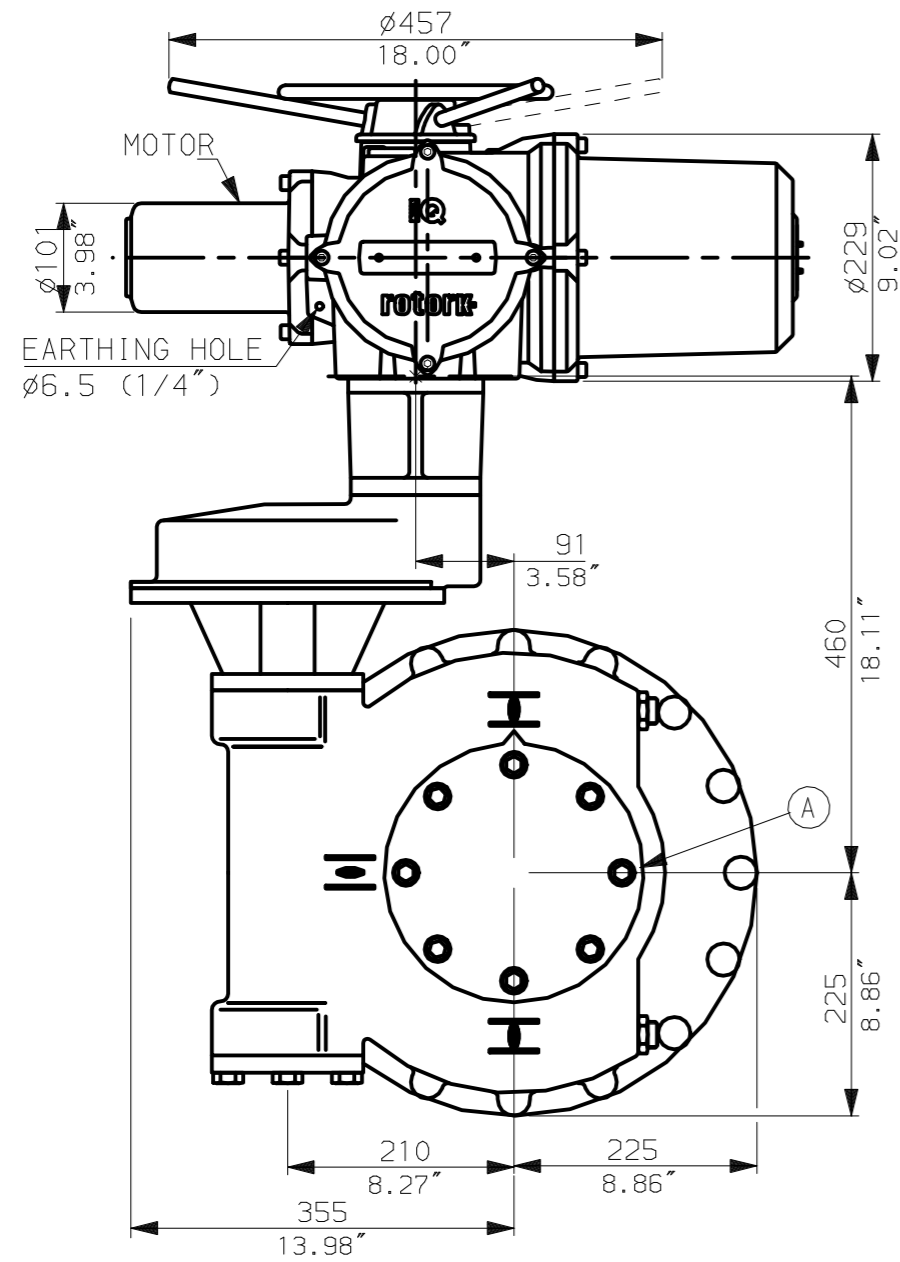

N.B. KEYWAY POS. CAN BE MOVED 90 OR 180° BY REMOVING 8 SCREWS MARKED (A) AND ROTATING OUTPUT SLEEVE.

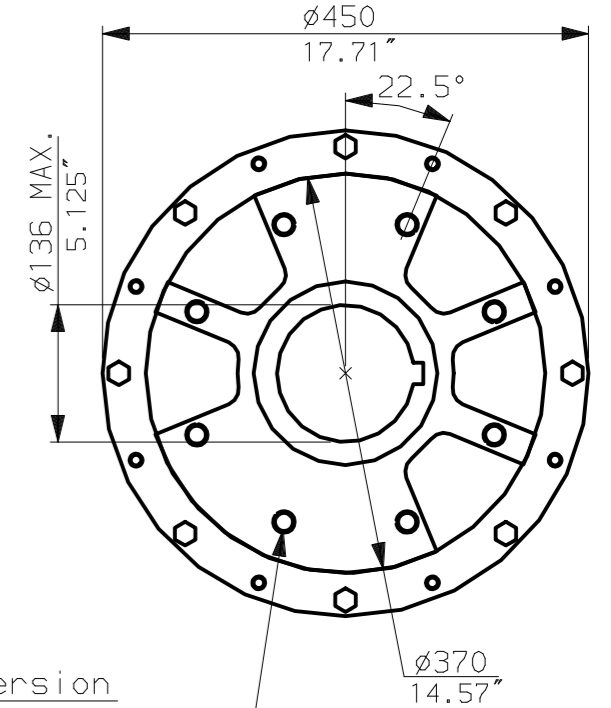

"F" version

8 HOLES TAPPED M20 x 24 DP
EQUI-SPACED AS SHOWN ON A
298 PCD (ISO 5211-F30).

"FA" version

8 HOLES TAPPED 3/4" UNC x 0.94" dp
EQUI-SPACED AS SHOWN ON A
11.75" PCD (MSS SP101-FA30).

NOTE:
Gearbox is shown with LOW Ratio Input Reducer.
(ie Ratios 120, 180, 240, 360)
See Data Sheet with IW7Rh for HIGH ratio option.

rotork
www.rotork.com

Rotork Controls Ltd.
Bath England, BA1 3JQ.
(Phone 01225-733200)
Rotork Controls Inc.
Rochester, NY 14624
(Phone 585-328-1550)

Title IQ10, 12, 18, (+IQS12), LTHW, IW(MOW)7(+72)RL	
STANDARD DIMENSIONAL DATA	
Drawn CAD	Checked PRE Ref Data Sheet
Date 150605	Job No IQ1LTHW_IW7R

02	4.69" corrected from 6.50"
01 Issue	First Issue.
Scale	1:7 THIRD ANGLE PROJECTION
Drawing Number	IQ1LTHW_IW7RL

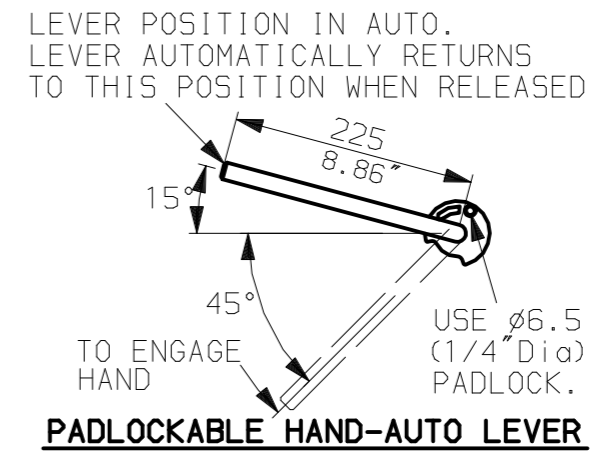
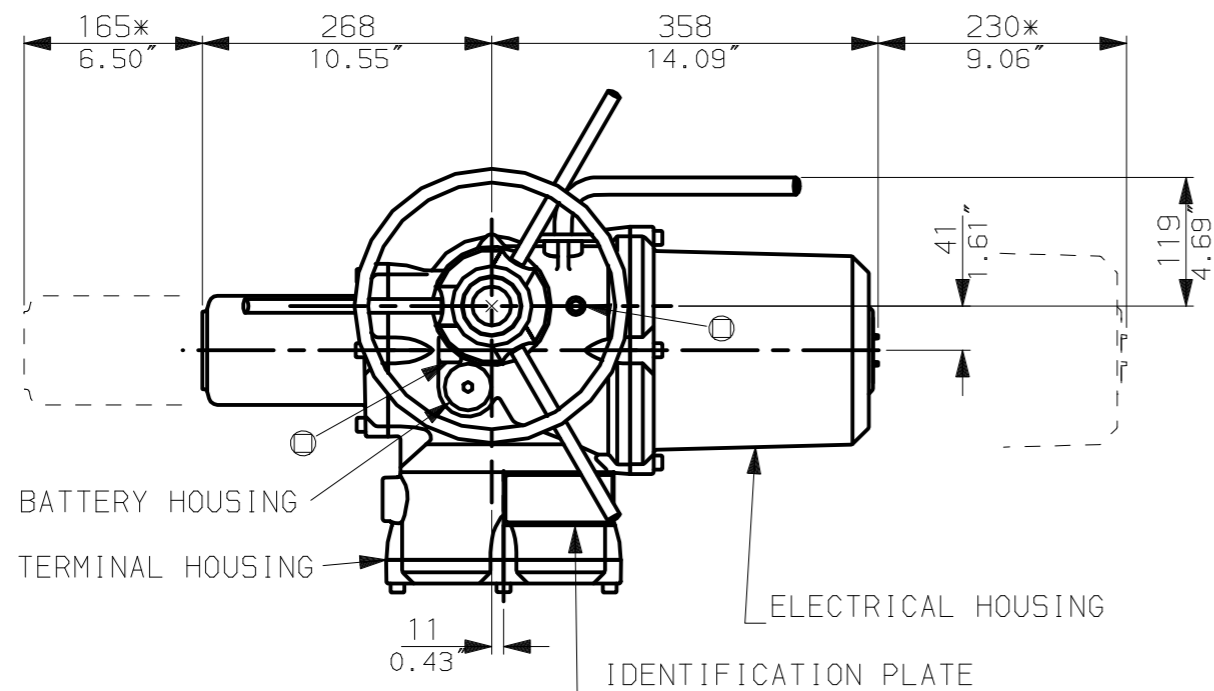

NOTES:
: DIMENSIONS WITH '*' INDICATE COVER REMOVAL ALLOWANCE
: NETT WEIGHT = 194kg (427lbs)
: \odot = OIL FILLER/DRAIN PLUG
: THE INTERFACE PROVIDED FOR MOUNTING THE ACTUATOR OR SECOND STAGE GEARBOX ONTO THE VALVE SHOULD CONFORM TO GOOD ENGINEERING PRACTICES, ENSURING ADEQUATELY TOLERANCED LIMITS FOR PARALLELISM, PERPENDICULARITY AND CONCENTRICITY.

CONDUIT ENTRIES (N.T.S)

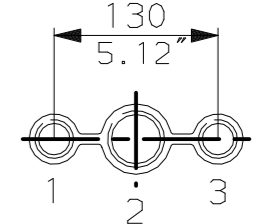

Nos.1 & 3 TAPPED 1" NPT
No.2 TAPPED 1 1/2" NPT
STD ALTERNATIVES IF SPECIFIED
2 X M25, 1 X M40
2 X PG16, 1 X PG29

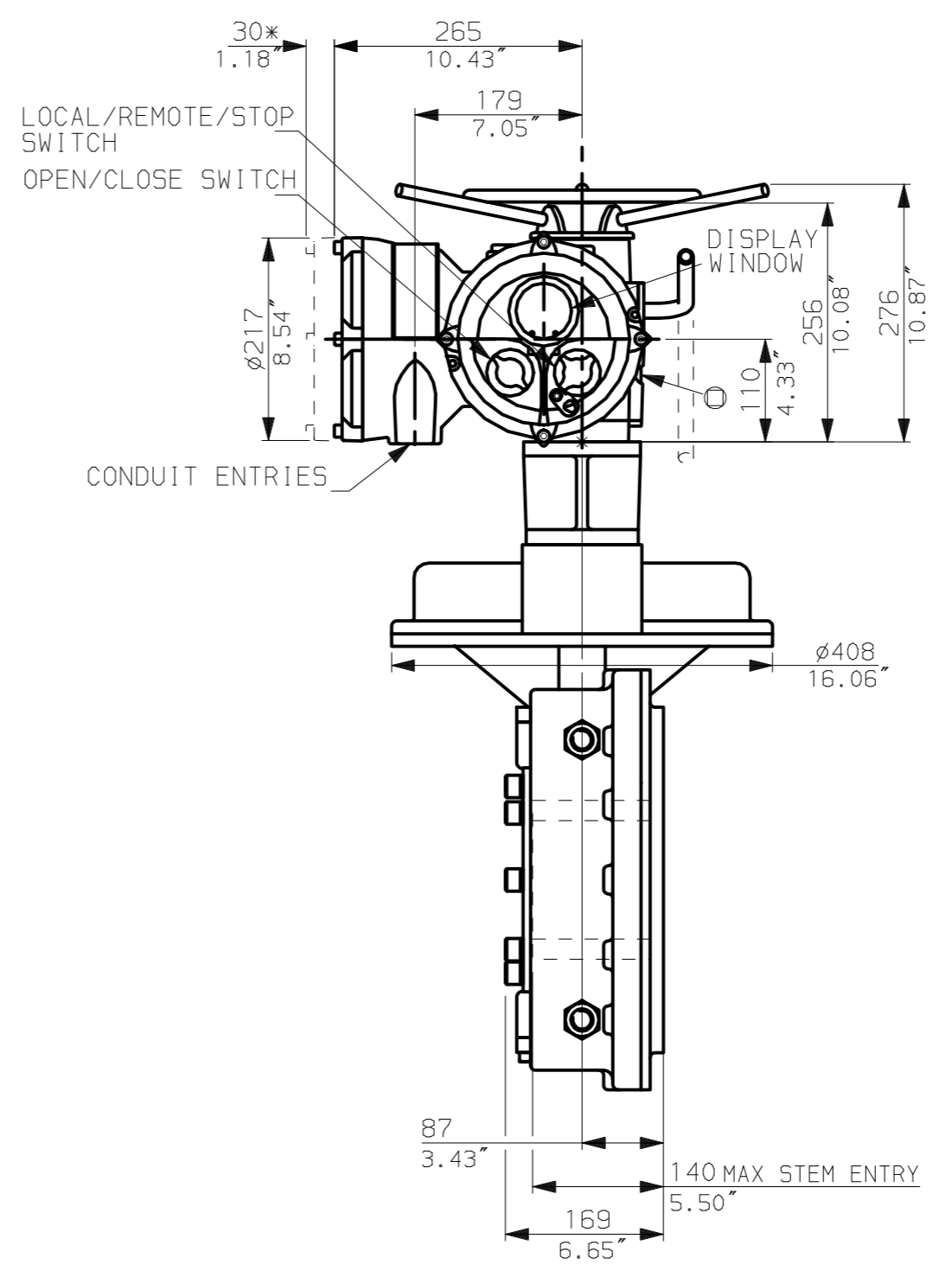
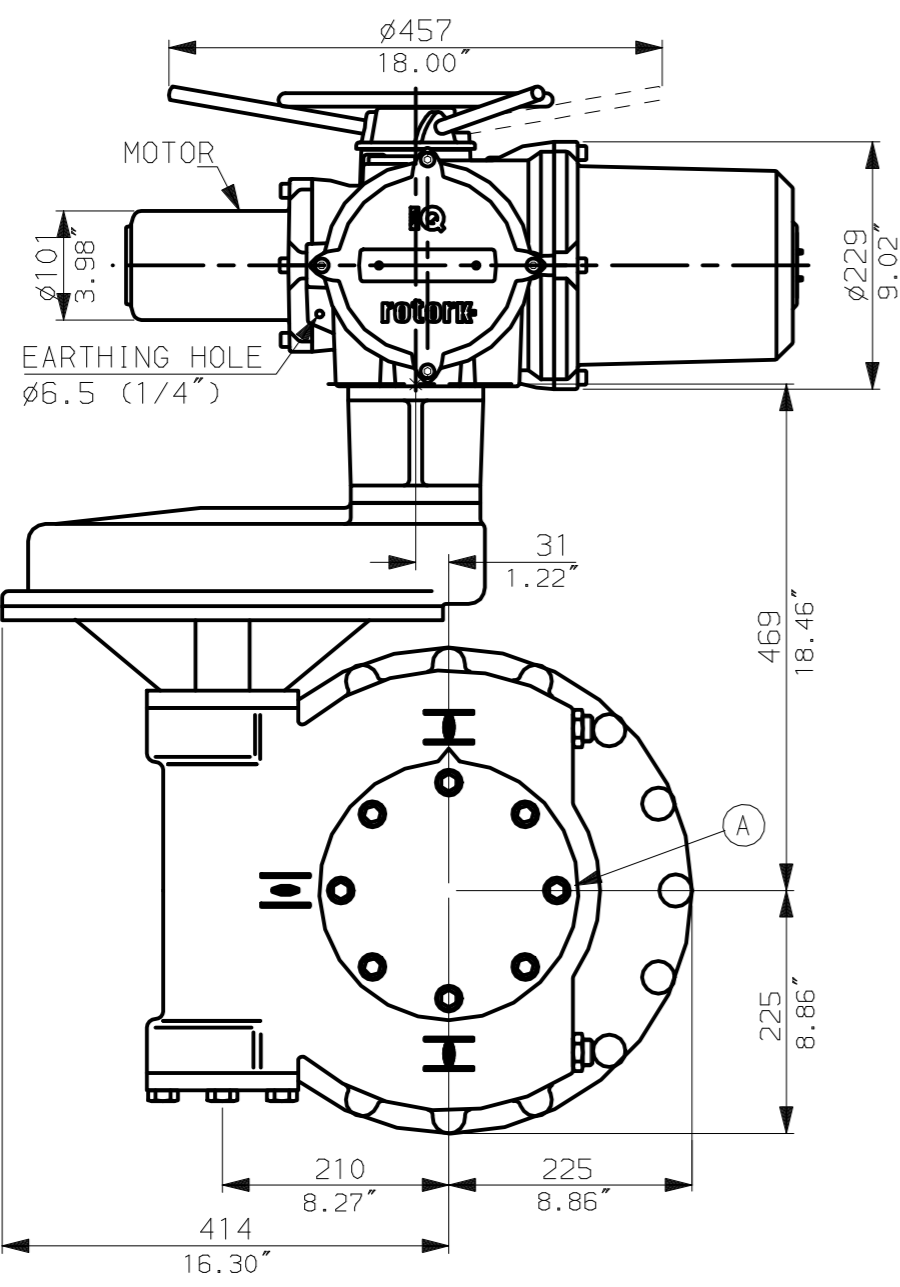

N.B. KEYWAY POS. CAN BE MOVED 90 OR 180° BY REMOVING 8 SCREWS MARKED (A) AND ROTATING OUTPUT SLEEVE.

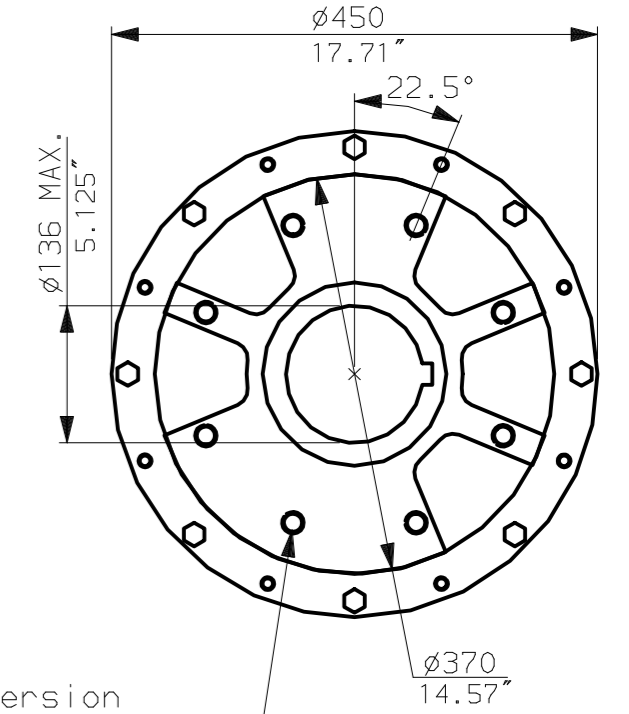

"F" version
8 HOLES TAPPED M20 x 24 DP
EQUI-SPACED AS SHOWN ON A
298 PCD (ISO 5211-F30).

"FA" version
8 HOLES TAPPED 3/4" UNC x 0.94" dp
EQUI-SPACED AS SHOWN ON A
11.75" PCD (MSS SP101-FA30).

NOTE:
Gearbox is shown with HIGH Ratio Input Reducer.
(ie Ratios 480,540,720)
See Data Sheet with IW7RL for LOW ratio option.

rotork
www.rotork.com

Rotork Controls Ltd.
Bath England, BA1 3JQ.
(Phone 01225-733200)

Rotork Controls Inc.
Rochester, NY 14624
(Phone 585-328-1550)

Title IQ10, 12, 18, (+IQS12), LTHW, IW(MOW)7(+72)Rh,	
STANDARD DIMENSIONAL DATA	
Drawn CAD	Checked PRE Ref Data Sheet
Date 150605	Job No IQ1LTHW_IW7Rh

02	4.69" corrected from 6.50"
01 Issue	First Issue.
Scale	1:7 THIRD ANGLE PROJECTION
Drawing Number	IQ1LTHW_IW7Rh

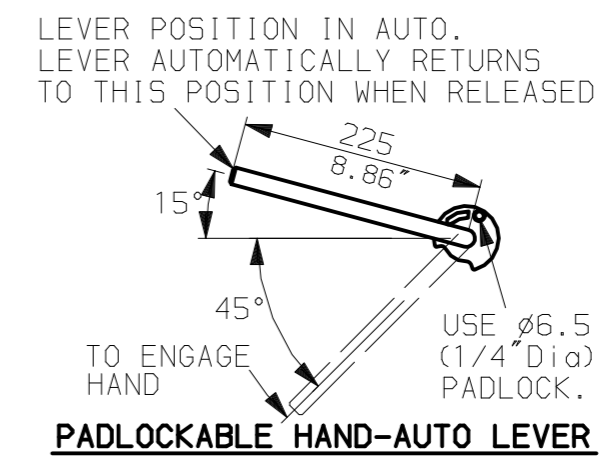
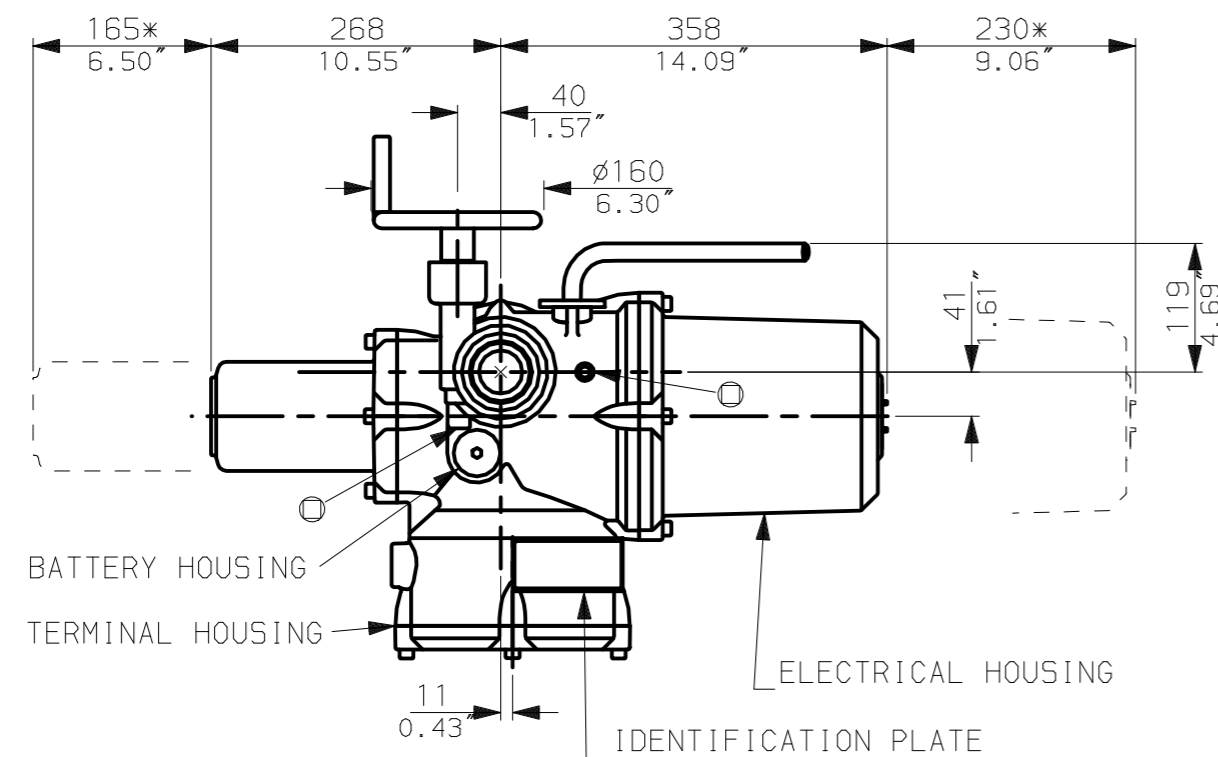

NOTES:
 : DIMENSIONS WITH '*' INDICATE COVER REMOVAL ALLOWANCE
 : NETT WEIGHT = 184kg (405lbs)
 : = OIL FILLER/DRAIN PLUG
 : THE INTERFACE PROVIDED FOR MOUNTING THE ACTUATOR OR SECOND STAGE GEARBOX ONTO THE VALVE SHOULD CONFORM TO GOOD ENGINEERING PRACTICES, ENSURING ADEQUATELY TOLERANCED LIMITS FOR PARALLELISM, PERPENDICULARITY AND CONCENTRICITY.

CONDUIT ENTRIES (N.T.S)

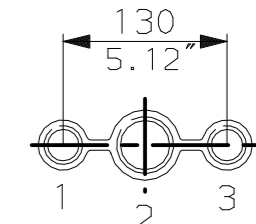

Nos.1 & 3 TAPPED 1" NPT
 No.2 TAPPED 1 1/2" NPT
 STD ALTERNATIVES IF SPECIFIED
 2 X M25, 1 X M40
 2 X PG16, 1 X PG29

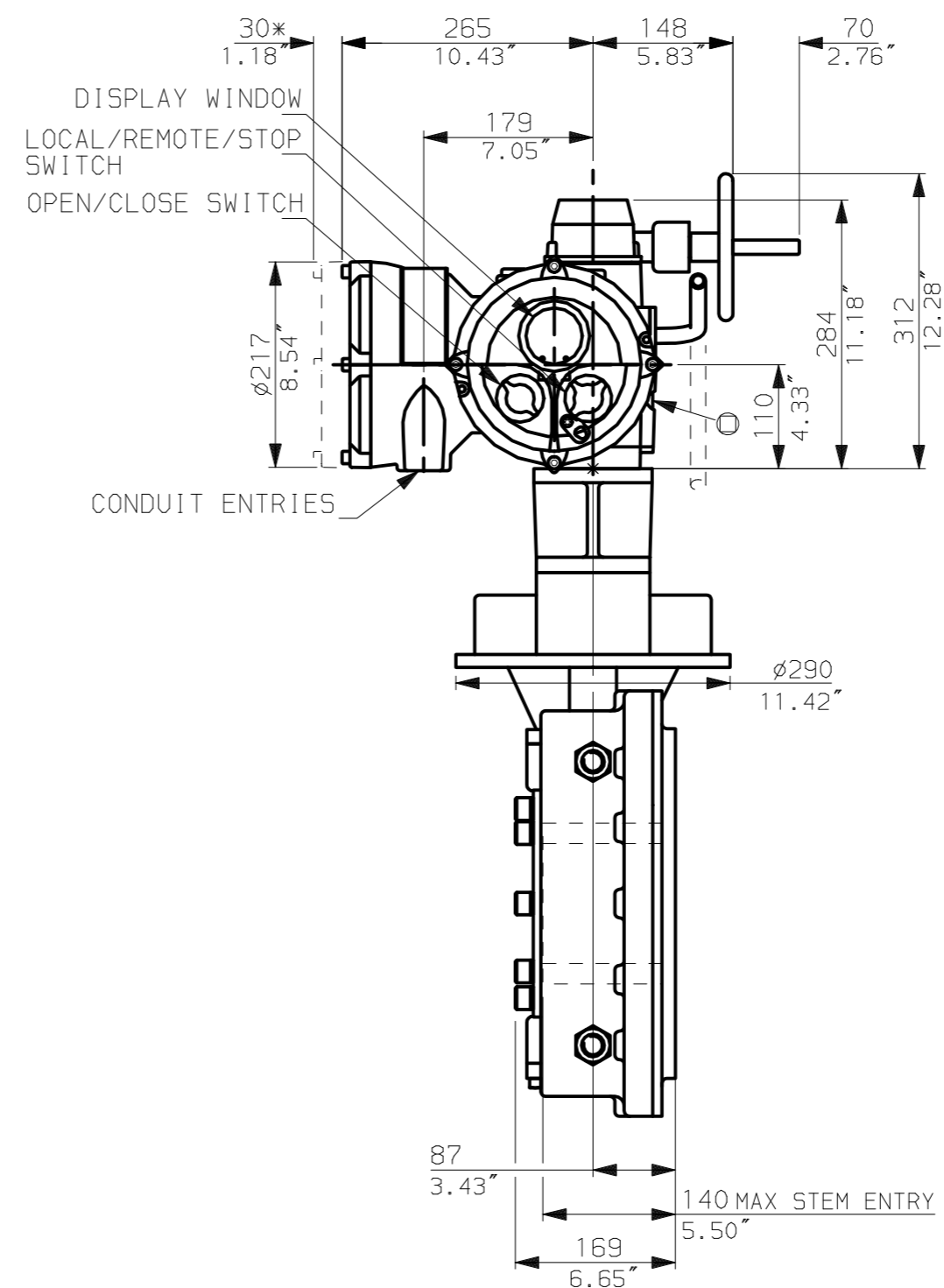
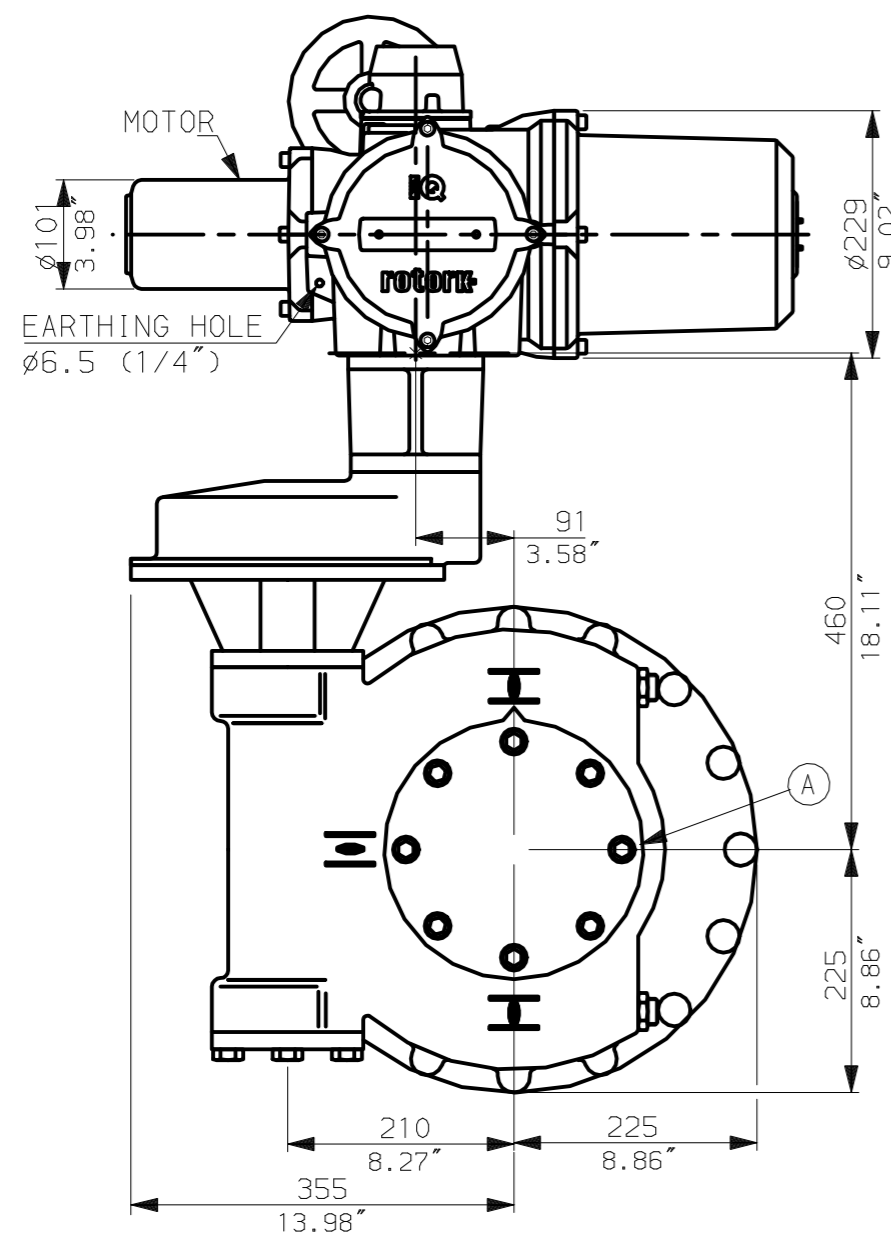

N.B. KEYWAY POS. CAN BE MOVED 90 OR 180° BY REMOVING 8 SCREWS MARKED (A) AND ROTATING OUTPUT SLEEVE.

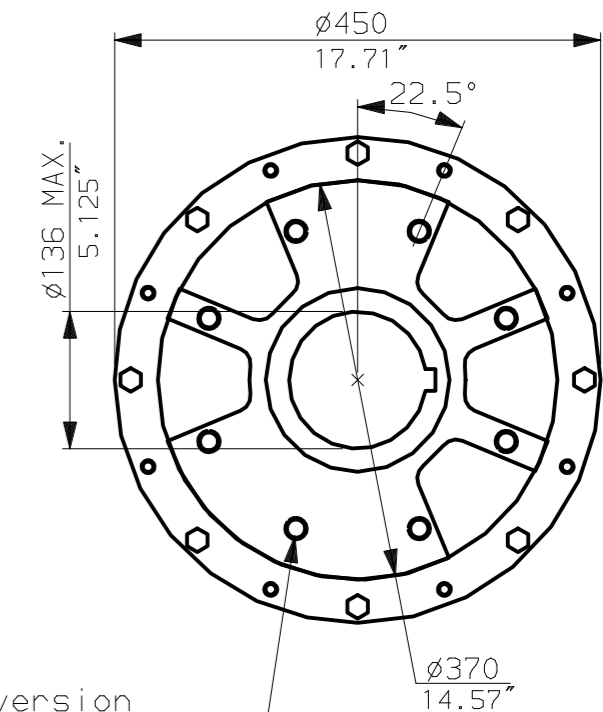

"F" version

8 HOLES TAPPED M20 x 24 DP
 EQUI-SPACED AS SHOWN ON A
 298 PCD (ISO 5211-F30).

"FA" version

8 HOLES TAPPED 3/4" UNC x 0.94" dp
 EQUI-SPACED AS SHOWN ON A
 11.75" PCD (MSS SP101-FA30)

NOTE:
 Gearbox is shown with LOW Ratio Input Reducer.
 (ie Ratios 120, 180, 240, 360)
 See Data Sheet with IW7Rh for HIGH ratio option.

rotork
 www.rotork.com

Rotork Controls Ltd.
 Bath England, BA1 3JQ.
 (Phone 01225-733200)
 Rotork Controls Inc.
 Rochester, NY 14624
 (Phone 585-328-1550)

Title IQ10, 12, 18, (+IQS12), SHW, IW (MOW) 7 (+72) RL,		
STANDARD DIMENSIONAL DATA		
Drawn CAD	Checked PRE	Ref Data Sheet
Date 150605	Job No	IQ1SHW_IW7RL

02	4.69" corrected from 6.50"
01	First Issue.
Scale	1:7 THIRD ANGLE PROJECTION
Drawing Number	IQ1SHW_IW7RL

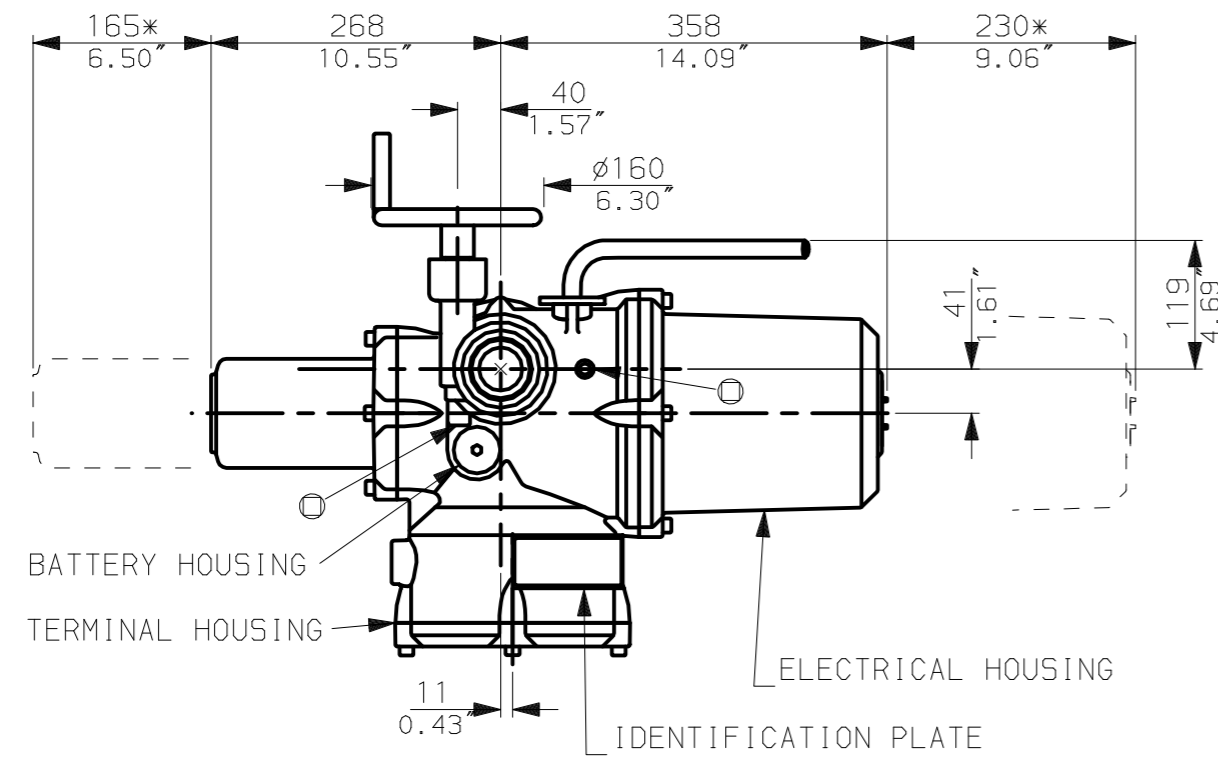

LEVER POSITION IN AUTO.
LEVER AUTOMATICALLY RETURNS
TO THIS POSITION WHEN RELEASED

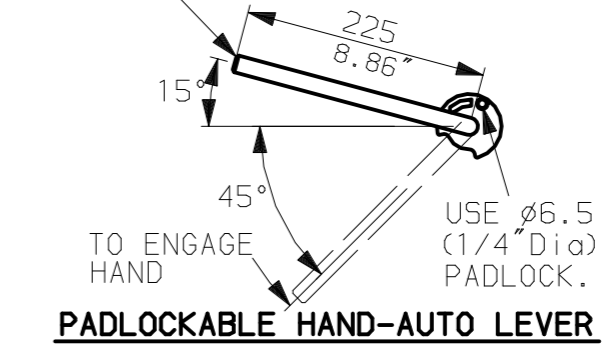

NOTES:
: DIMENSIONS WITH '*' INDICATE
COVER REMOVAL ALLOWANCE
: NETT WEIGHT = 194kg (427lbs)
: = OIL FILLER/DRAIN PLUG
: THE INTERFACE PROVIDED FOR MOUNTING THE
ACTUATOR OR SECOND STAGE GEARBOX ONTO THE
VALVE SHOULD CONFORM TO GOOD ENGINEERING
PRACTICES, ENSURING ADEQUATELY TOLERANCED
LIMITS FOR PARALLELISM, PERPENDICULARITY
AND CONCENTRICITY.

CONDUIT ENTRIES (N.T.S)

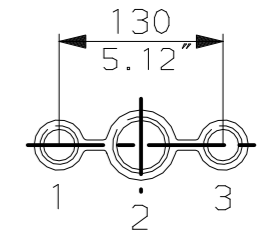

Nos.1 & 3 TAPPED 1" NPT
No.2 TAPPED 1 1/2" NPT
STD ALTERNATIVES IF SPECIFIED
2 X M25, 1 X M40
2 X PG16, 1 X PG29

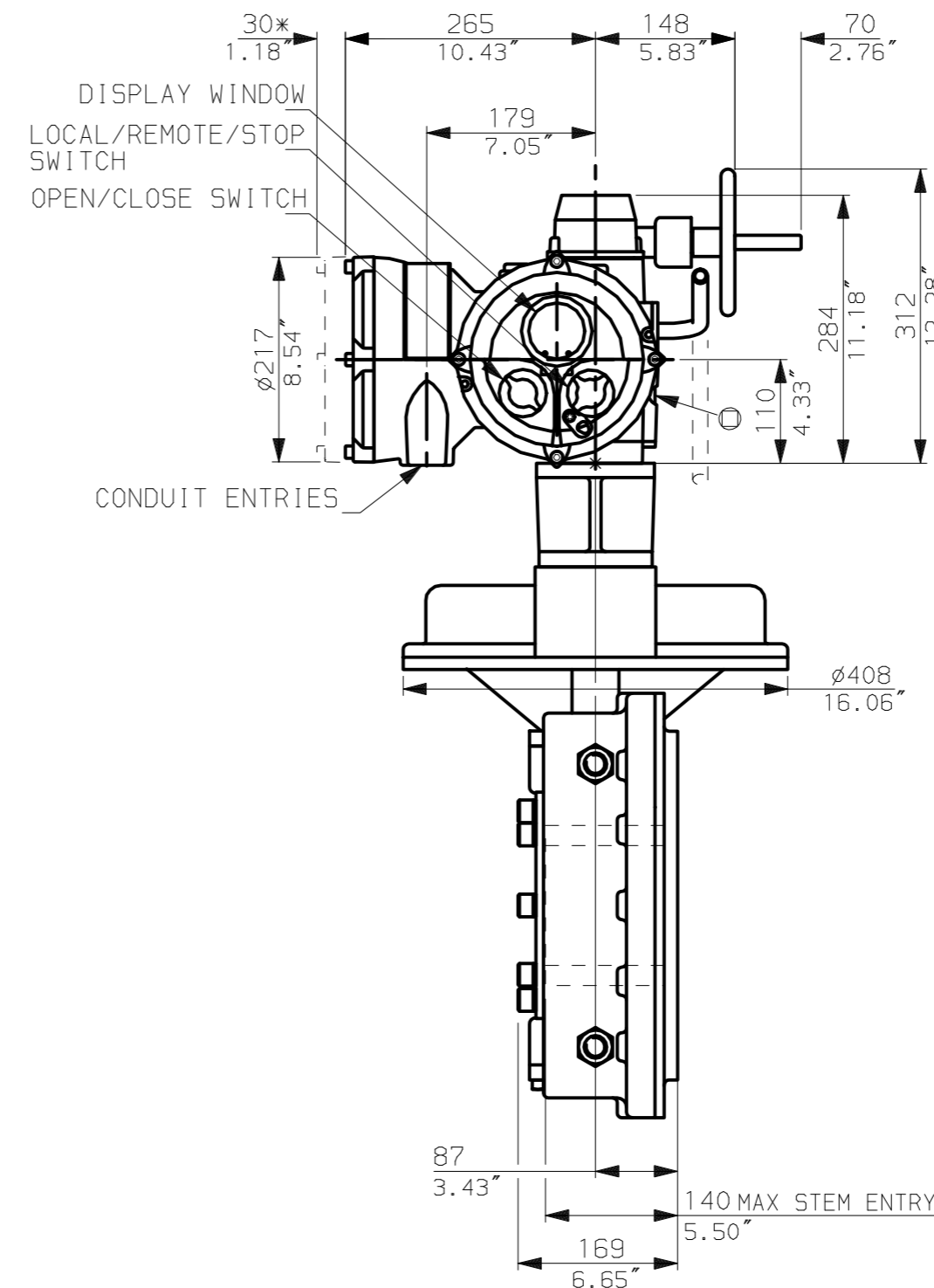
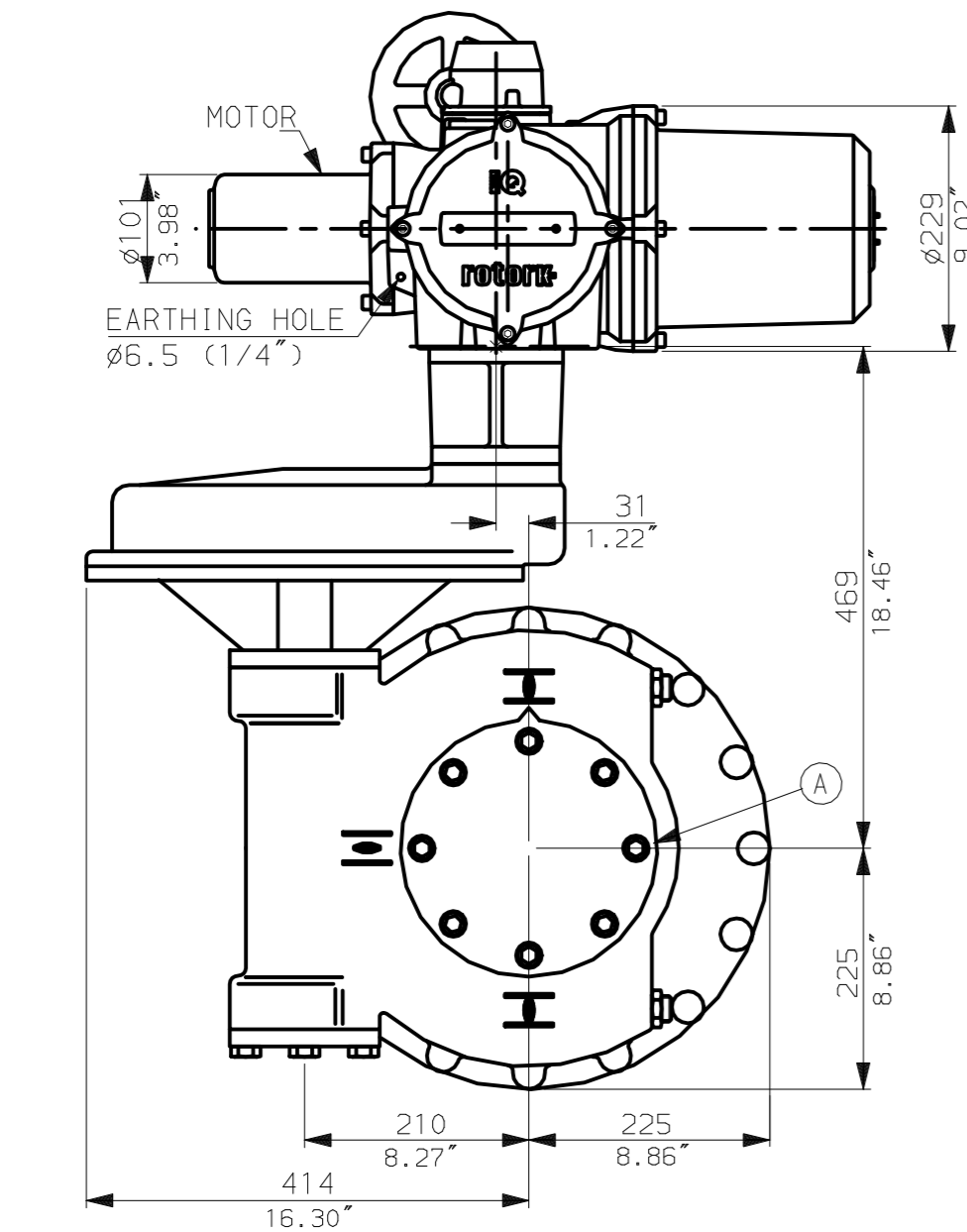

N.B. KEYWAY POS. CAN BE MOVED
90 OR 180° BY REMOVING 8 SCREWS
MARKED (A) AND ROTATING OUTPUT
SLEEVE.

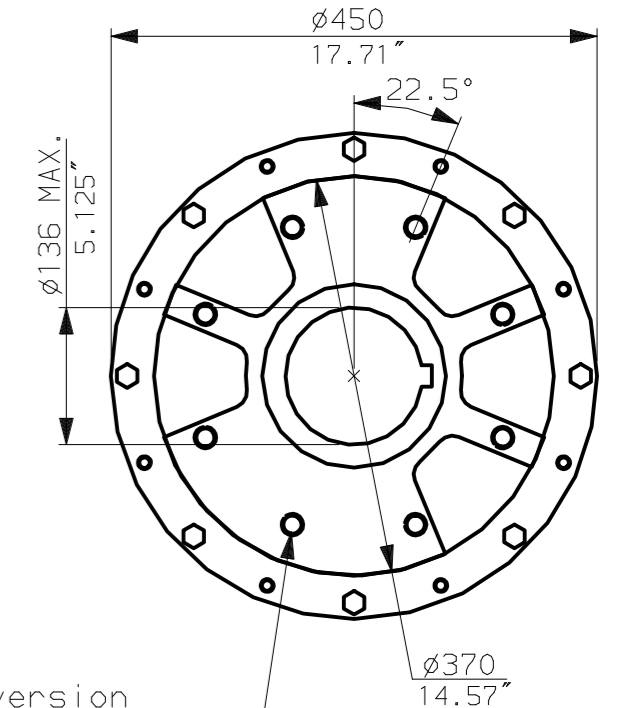

"F" version

8 HOLES TAPPED M20 x 24 DP
EQUI-SPACED AS SHOWN ON A
298 PCD (ISO 5211-F30).

"FA" version

8 HOLES TAPPED 3/4" UNC x 0.94" dp
EQUI-SPACED AS SHOWN ON A
11.75" PCD (MSS SP101-FA30).

NOTE:
Gearbox is shown with HIGH Ratio Input Reducer.
(ie Ratios 480,540,720)
See Data Sheet with IW7RL for LOW ratio option.

rotork
www.rotork.com

Rotork Controls Ltd.
Bath England, BA1 3JQ.
(Phone 01225-733200)
Rotork Controls Inc.
Rochester, NY 14624
(Phone 585-328-1550)

Title IQ10, 12, 18, (+IQS12), SHW, IW (MOW) 7 (+72)Rh,		
STANDARD DIMENSIONAL DATA		
Drawn CAD	Checked PRE	Ref Data Sheet
Date 150605	Job No IQ1SHW_IW7Rh	

02	4.69" corrected from 6.50"
01 Issue	First Issue.
Scale	1:7 THIRD ANGLE PROJECTION
Drawing Number	IQ1SHW_IW7Rh