

FOR TYPICAL REMOTE CONTROL
DETAILS, SEE DOCUMENT
RWS122

VOLTAGE OPTIONS	
VOLTAGE	SIZE
110VDC	10,12,18,20,25
48VDC	10,12,18
24VDC	10

REFER TO SHEET 2 FOR NOTES
& OPTION PCB'S IF FITTED

Iss	Date	Chkd	Revision Details
1	181214	JC1	FIRST ISSUE

www.rotork.com

ROTORK CONTROLS LTD BATH, BA1 3JQ ENGLAND Tel:01225-733200	ROTORK CONTROLS INC ROCHESTER NY 14624, USA Tel:585-247-2304
---	---

IQ DC +SINGLE CHANNEL MODBUS MODULE + FOLOMATIC & CPT		Issue No	Sheet
Circuit Diagram Number 143M2000		1	1 of 2
B1	C1	B2	C2

SLOT A

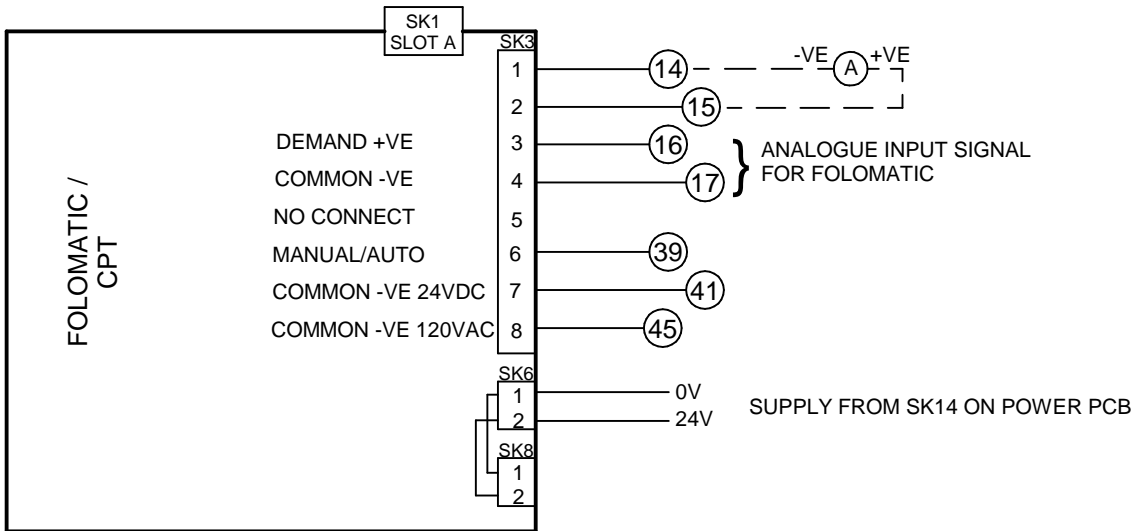

FOR MANUAL/AUTO CONNECTIONS AND
DETAILS OF FOLOMATIC/CPT FUNCTIONS
REFER TO ROTORK PUBLICATION PUB002-041

SLOT B

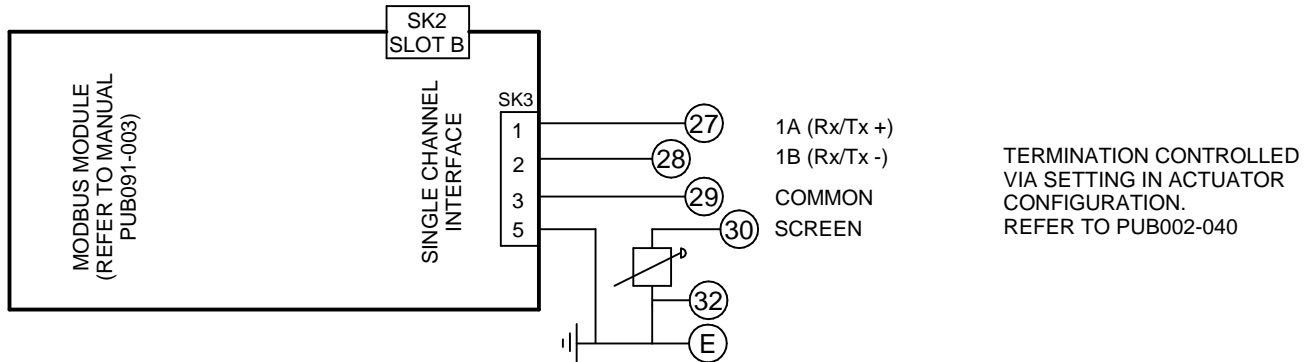

RS-485 LINES REQUIRE EXTERNAL POLARISATION AT
ONE LOCATION FOR WHOLE BUS SEGMENT.

NOTES

1.FUSES:

- FS1 - 6A anti-surge.
- Actuator rated voltage specified on nameplate. Voltage tolerance +/-10%, applies for rated torque performance; duty cycle and speed is not guaranteed.

2.REMOTE CONTROL:

- For typical remote control circuits refer to:
 - RWS indicated or PUB002-041.
- For DC and AC control, connect -ve/0V to terminal 36.
- (For negative switch / positive common, refer to RWS indicated).
- Control signal threshold voltages:
 - DC: "on" $\geq 16Vdc$ / "off" $\leq 8Vdc$, max 60Vdc.
 - AC: "on" $\geq 60Vac$ / "off" $\leq 40Vac$, max 120Vac.
- Control signal duration to be 300ms minimum.
- Maximum current drawn from remote control signals is:
 - 8mA at 24Vdc or 12mA at 120Vac.
- Supply provided on terminals 4 & 5:
 - Intended for remote control.
 - Max external load 5W at 24Vdc / 5VA at 120Vac

5.DC:

- Default for sleep mode is DISABLED.
- Sleep mode can be enabled by moving link LK1 from NORM to SOLAR. (Basic DC solar is 150B0000)
- Actuator will remain powered up at all times while supply is present.
- 24VDC will be lost when in sleep mode.
- If customer supply is needed to wake actuator link LK3 must be moved to CUST for maintained customer supply.

3.INDICATION:

- For typical position, status and alarm indication see PUB002-041.
- “S” contacts are user configurable and are shown in their default setting.
- Refer to PUB002-040 for functions and configuration instructions.
- Monitor Relay indicates actuator availability for remote control (shown “unavailable”). It can be configured to exclude local/remote selection.
- Refer to PUB002-040 for monitored functions and configuration instructions.
- Voltage applied to indication contacts must not exceed 150Vac
- Individual Switch current must not exceed 3.5A inductive, 5A resistive and no more than 8A in total for all 4 contacts.

4.BATTERY:

- Battery maintains local and remote “S” contact indication only.
- Refer to installation manual for approved replacement battery types.