

NOTES:

1. 4-20 mA OUTPUT, 24VDC NOMINAL, (18-30 VDC MAX)
2. SEE ADDITIONAL PAGES FOR COMMUNICATIONS W/D IF ATTACHED

SHT
1 OF 4

A

M12-MD

REV
B

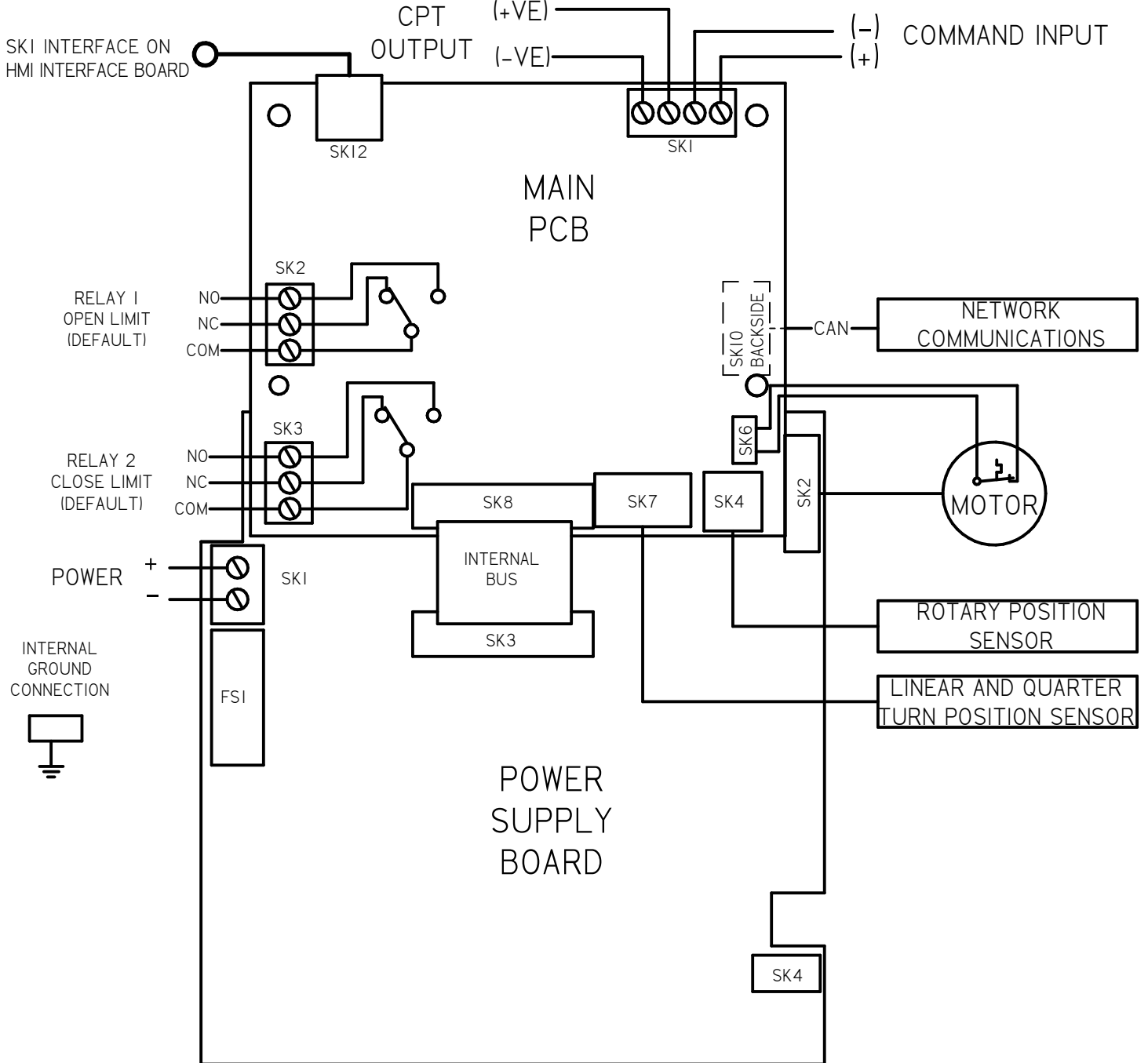

B	ECR 18122 RIRO RENUMBER RELAYS	GVM 6/23/15
A	INITIAL RELEASE	GVM 1-12-15
REV	DESCRIPTION	DATE

<p>TOLERANCES UNLESS OTHERWISE SPECIFIED .XX = ±.02 XXX = ±.005 ANGULAR ±1°</p>		
<p>SCALE: NTS</p>		
DRAWN:	PROD. DV.	PROD. ENG.
GVM		
DATE:	DATE:	DATE:
1-12-15		

rotork[®]
Process Controls
MILWAUKEE, WISCONSIN, USA

This print is the property of Rotork Process Controls and is loaned in confidence subject to return. All rights to design or invention are reserved.

TITLE :
CMA WIRING DIAGRAM

FOR :
DC POWER OPERATION
LOCAL CONTROLS, MODBUS & RIRO
TERMINAL CONNECTIONS

SHT
1 OF 4

A

M12-MD

HMI INTERFACE BOARD



SK12 INTERFACE ON
MAIN PCB BOARD

B	ECR 18122 RIRO RENUMBER RELAYS	GVM 6/23/15
A	INITIAL RELEASE	GVM 1-12-15
REV	DESCRIPTION	DATE

<p>TOLERANCES UNLESS OTHERWISE SPECIFIED .XX = ±.02 XXX = ±.005 ANGULAR ±1°</p>		
<p>SCALE: NTS</p>		
DRAWN: GVM	PROD. DV.	PROD. ENG.
DATE: 1-12-15	DATE:	DATE:

rotork[®]
Process Controls
MILWAUKEE, WISCONSIN, USA

This print is the property of Rotork Process Controls and is loaned in confidence subject to return. All rights to design or invention are reserved.

<p>TITLE : CMA WIRING DIAGRAM</p>		
<p>FOR : DC POWER OPERATION LOCAL CONTROLS, MODBUS & RIRO TERMINAL CONNECTIONS</p>		
SHT 2 OF 4	A	M12-MD

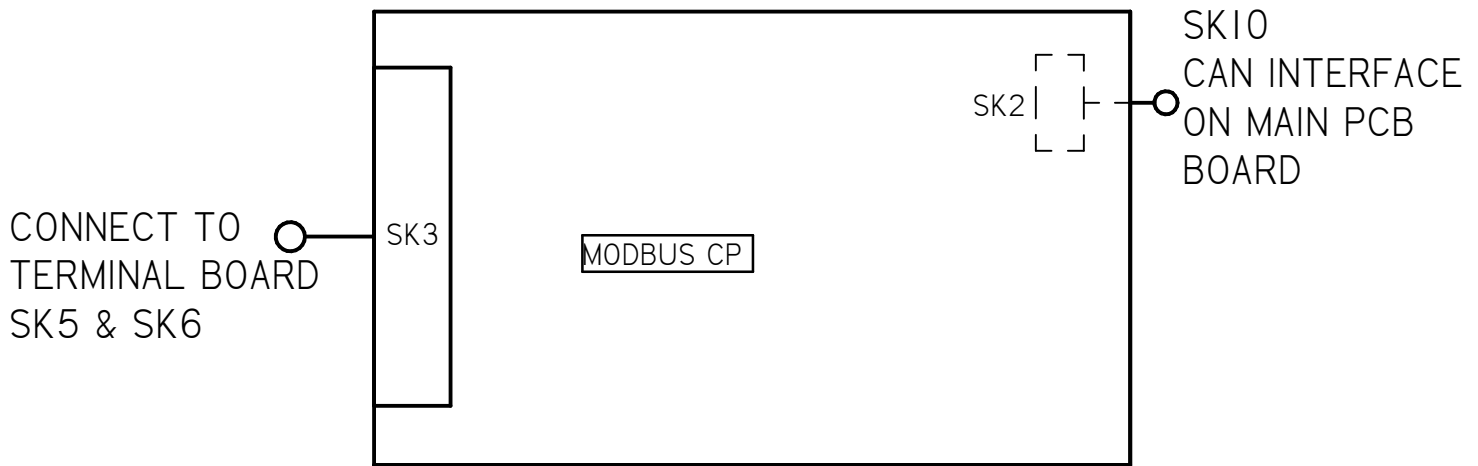
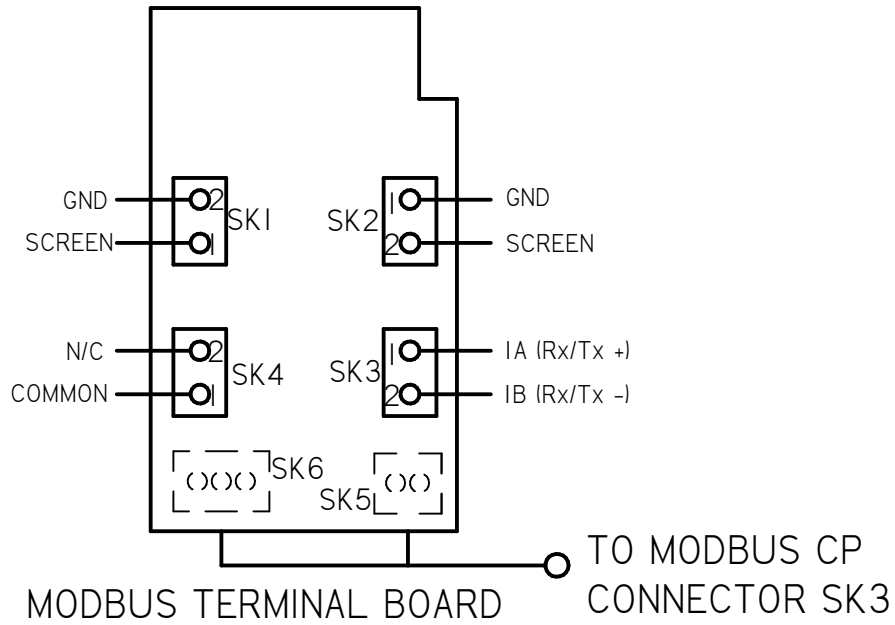

B	ECR 18122 RIRO RENUMBER RELAYS	GVM 6/23/15
A	INITIAL RELEASE	GVM 1-12-15
REV	DESCRIPTION	DATE

TOLERANCES UNLESS OTHERWISE SPECIFIED .XX = ±.02 XXX = ±.005 ANGULAR ±1°		
SCALE: NTS		
DRAWN: GVM	PROD. DV.	PROD. ENG.
DATE: 1-12-15	DATE:	DATE:

Process Controls
 MILWAUKEE, WISCONSIN, USA

This print is the property of Rotork Process Controls and is loaned in confidence subject to return. All rights to design or invention are reserved.

TITLE : CMA WIRING DIAGRAM		
FOR : DC POWER OPERATION LOCAL CONTROLS, MODBUS & RIRO TERMINAL CONNECTIONS		
SHT 3 OF4	A	M12-MD

RIRO REMOTE INPUTS - DEFAULT SETTINGS

INPUT	FUNCTION	CONTACT FORM
I/P1	CLOSE COMMAND	NORMALLY OPEN
I/P2	STOP/MAINTAIN	NORMALLY OPEN
I/P3	OPEN COMMAND	NORMALLY OPEN
I/P4	ESD	NORMALLY OPEN

REFER TO PUB094-004 FOR FULL DETAILS

RIRO RELAY OUTPUTS- DEFAULT SETTINGS

INPUT	FUNCTION	CONTACT FORM
RELAY 5	NONE	ENERGIZE ON CONDITION
RELAY 6	NONE	ENERGIZE ON CONDITION
RELAY 7	NONE	ENERGIZE ON CONDITION
RELAY 8	NONE	ENERGIZE ON CONDITION

REFER TO PUB094-004 FOR FULL DETAILS

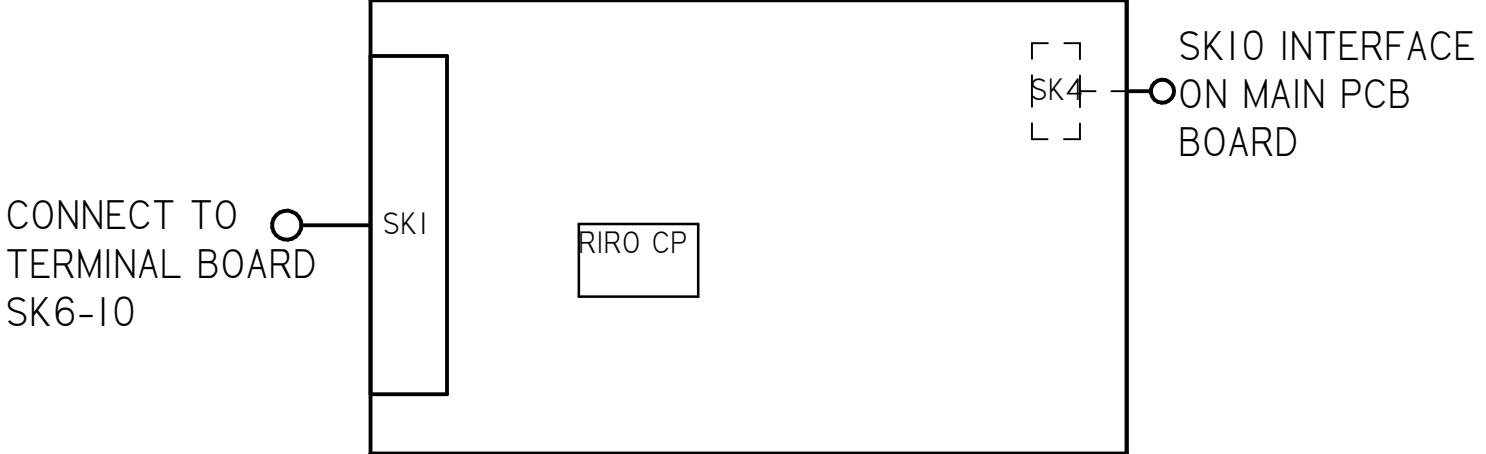
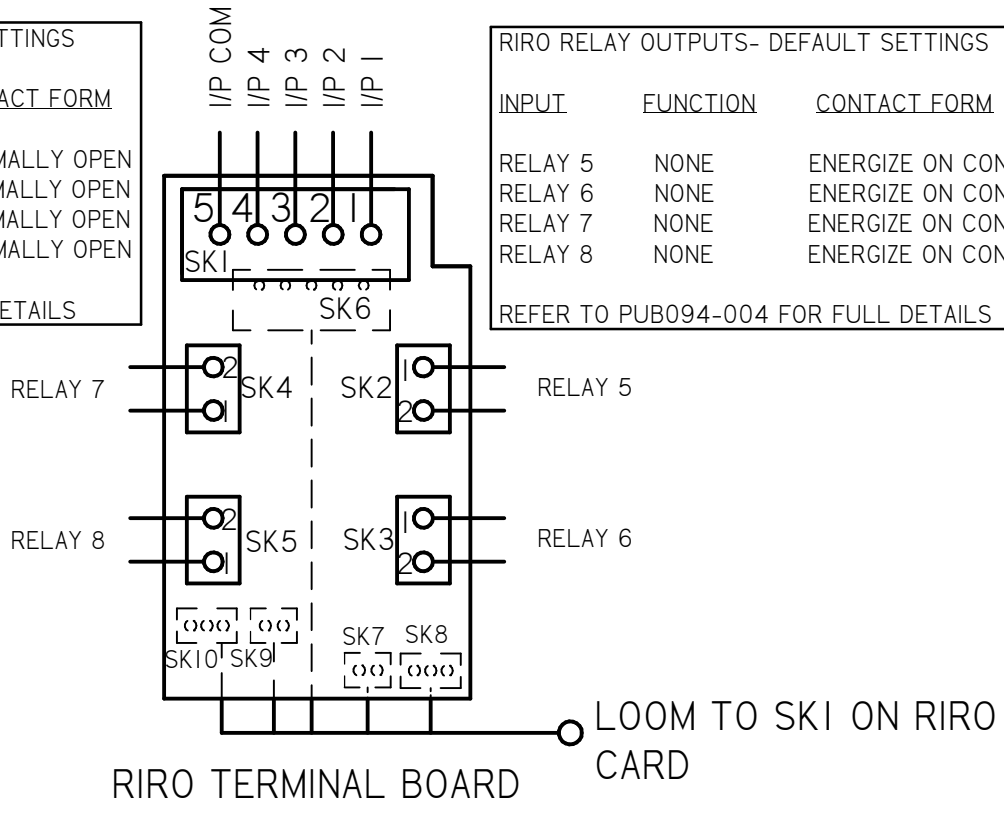

B	ECR 18122 RIRO RENUMBER RELAYS	GVM 6/23/15
A	INITIAL RELEASE	GVM 1-12-15
REV	DESCRIPTION	DATE

TOLERANCES
UNLESS OTHERWISE SPECIFIED
.XX = ±.02 XXX = ±.005 ANGULAR ±1°

SCALE: **NTS**

DRAWN: GVM	PROD. DV.	PROD. ENG.
DATE: 1-12-15	DATE:	DATE:

rotork
Process Controls
MILWAUKEE, WISCONSIN, USA

This print is the property of Rotork Process Controls and is loaned in confidence subject to return. All rights to design or invention are reserved.

TITLE :
CMA WIRING DIAGRAM

FOR :
DC POWER OPERATION
LOCAL CONTROLS, MODBUS & RIRO
TERMINAL CONNECTIONS

SHT 4 OF 4	A	M12-MD
---------------	----------	---------------