

CIRCUIT DRAWN WITH POWER SUPPLY OFF

FOR TYPICAL REMOTE CONTROL  
DETAILS, SEE DOCUMENT  
**RWS100**

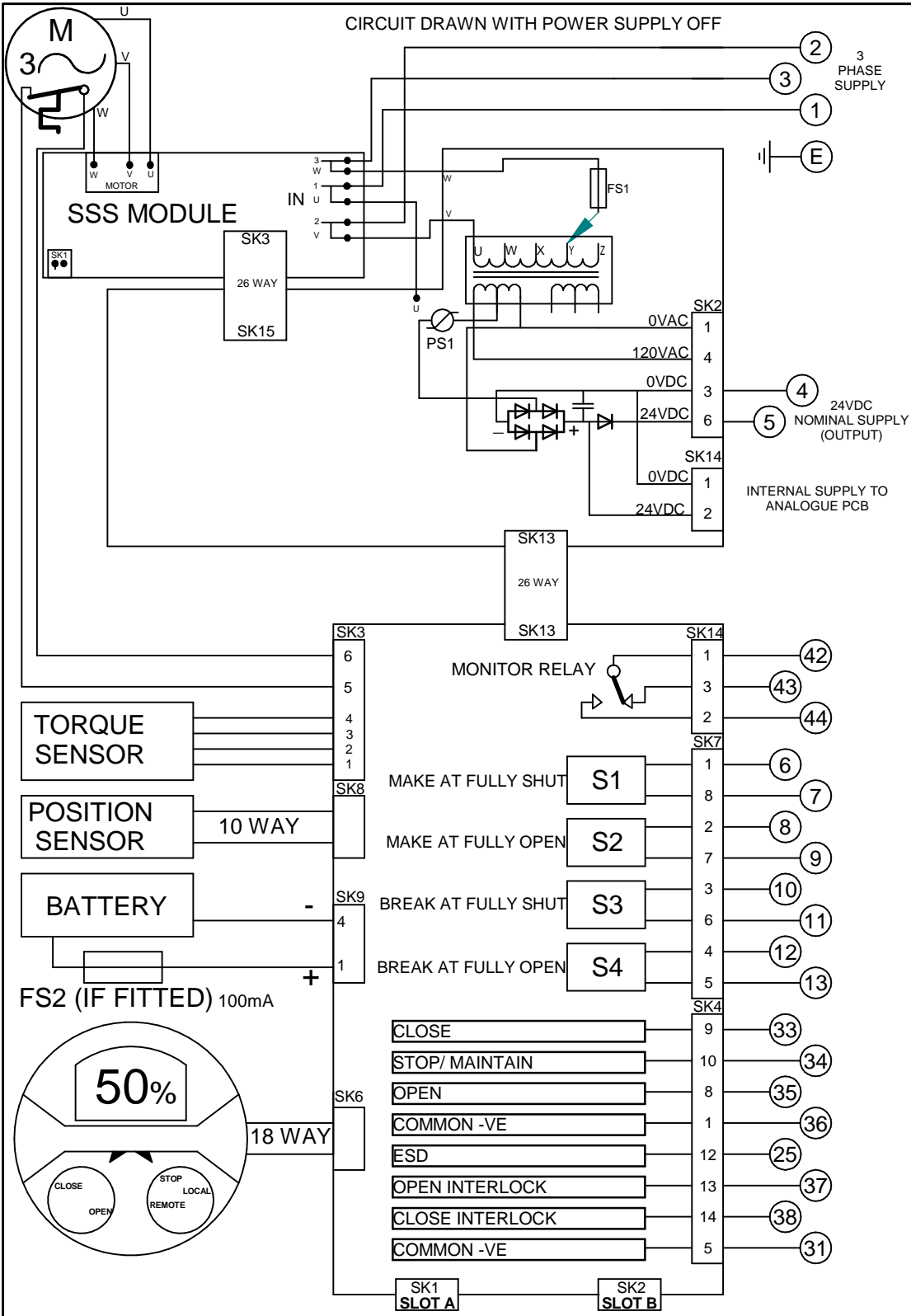

TRANSFORMER TAPPING OPTIONS	
Tap	Nominal 50/60Hz
TYPE 1	
W	220/230
X	380/400
Y	415/420
Z	440/460
FUZE FS1=250mA ANTI-SURGE	
TYPE 2	
W	346/380
X	480/500
Y	240/240
Z	550/575
FUZE FS1=250mA ANTI-SURGE	

REFER TO SHEET 2 FOR NOTES  
& OPTION PCB'S IF FITTED

THE ACTUATOR MUST BE  
PROTECTED USING SUITABLY  
RATED HIGH SPEED  
SEMI-CONDUCTOR FUSES ON THE  
INCOMING SUPPLY.

SUGGESTED FUSES :-  
IQ10-20:10 Amp FERRAZ G3330010  
IQ25-35:20 Amp FERRAZ K330013  
ALTERNATIVES =  
IQ10-20:10 Amp SIBA 50-179-06/10A  
IQ25-35:20 Amp SIBA 50-179-06/20A  
OR EQUIVALENT PROTECTIVE  
DEVICE.

Iss	Date	Chkd	Revision Details
1	310715	JC1	First Issue.
2	130616	PW	Updated notes on page 2.

**www.rotork.com**

ROTORK CONTROLS LTD  
BATH, BA1 3JQ  
ENGLAND  
Tel:01225-733200

ROTORK CONTROLS INC  
ROCHESTER  
NY 14624, USA  
Tel:585-247-2304

IQM + PAKSCAN + ANALOGUE MONITORING		Issue No	Sheet
Drawn by: PJW	Date : 310715	2	1
Base WD: 204K2000	Job No : --		
MI No : --	Circuit Diagram Number		
	<b>204K2000</b>		
	B1 C1 B2 C2		

## SLOT A

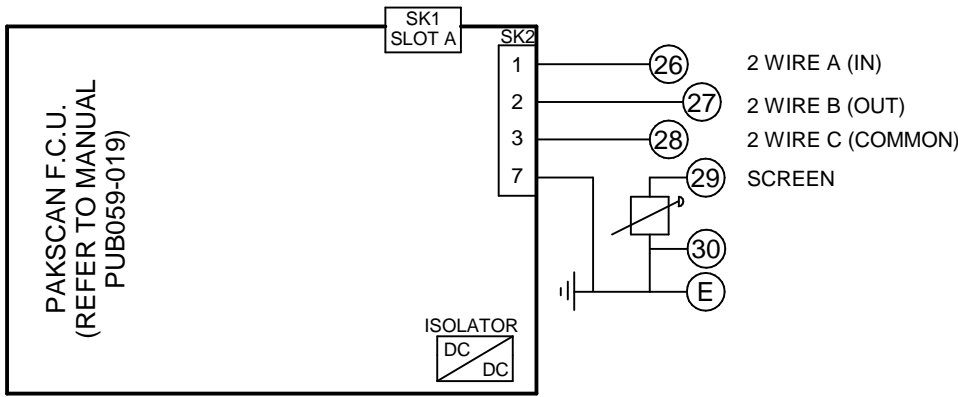

THE SETTING TOOL ENABLES THE PAKSCAN F.C.U  
BAUD RATE AND ADDRESS TO BE CONFIGURED

## SLOT B

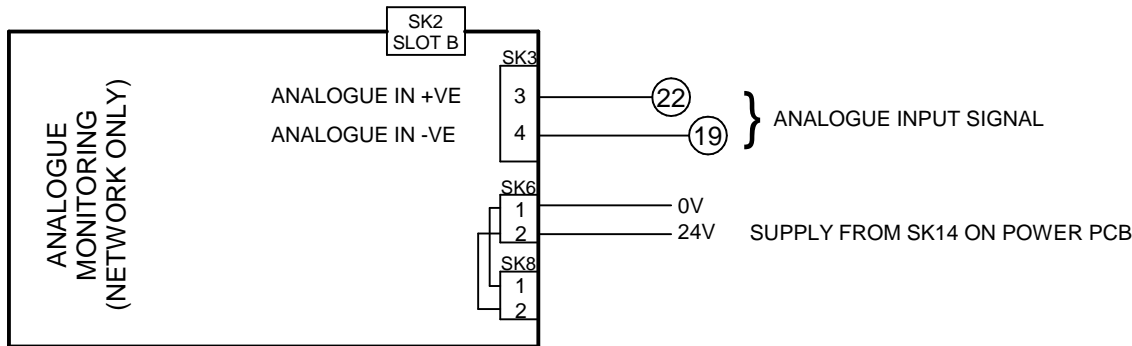

### NOTES

#### 1.FUSES:

- PS1 is a self-resetting fuse.
- Refer to publication PUB002-039 for approved fuses FS1 and FS2.
- Actuator rated voltage specified on nameplate. Voltage tolerance +/-10%, applies for rated torque performance; duty cycle is not guaranteed.

#### 2.REMOTE CONTROL:

- For typical remote control circuits refer to:
  - RWS indicated or PUB002-041.
- For DC and AC control, connect -ve/0V to terminal 36.
- (For negative switch / positive common, refer to RWS indicated).
- Control signal threshold voltages:
  - DC: "on"  $\geq 16Vdc$  / "off"  $\leq 8Vdc$ , max 60Vdc.
- Control signal duration to be 100ms minimum.
- Maximum current drawn from remote control signals is:
  - 8mA at 24Vdc .
- Supply provided on terminals 4 & 5:
  - Intended for remote control.
  - Max external load 5W at 24Vdc

#### 3.INDICATION:

- For typical position, status and alarm indication see PUB002-041.
- “S” contacts are user configurable and are shown in their default setting.
- Refer to PUB002-040 for functions and configuration instructions.
- Monitor Relay indicates actuator availability for remote control (shown “unavailable”). It can be configured to exclude local/remote selection.
- Refer to PUB002-040 for monitored functions and configuration instructions.
- Voltage applied to indication contacts must not exceed 150Vac
- Individual Switch current must not exceed 3.5A inductive, 5A resistive and no more than 8A in total for all 4 contacts.

#### 4.BATTERY:

- Battery maintains local and remote “S” contact indication only.
- Refer to installation manual for approved replacement battery types.