

H
G
F
E
D
C
B
A

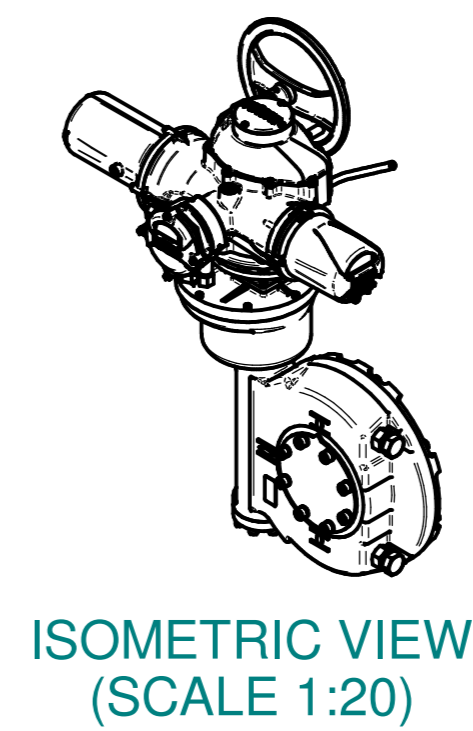

NOTES:
 :DIMENSIONS WITH "*" INDICATE COVER REMOVAL ALLOWANCE
 :NETT WEIGHT = 450kg/992lbs
 : = OIL FILLER/DRAIN PLUG
 :THE INTERFACE PROVIDED FOR MOUNTING THE ACTUATOR OR SECOND STAGE GEARBOX ONTO THE VALVE SHOULD CONFORM TO GOOD ENGINEERING PRACTICES, ENSURING ADEQUATELY TOLERANCED LIMITS FOR PARALLELISM, PERPENDICULARITY AND CONCENTRICITY.
 :ROTORK CANNOT BE HELD LIABLE FOR DAMAGE TO OUR EQUIPMENT CAUSED BY EXCESSIVE LOADING FROM COVER TUBES. (SEE ALSO PUB000-124)

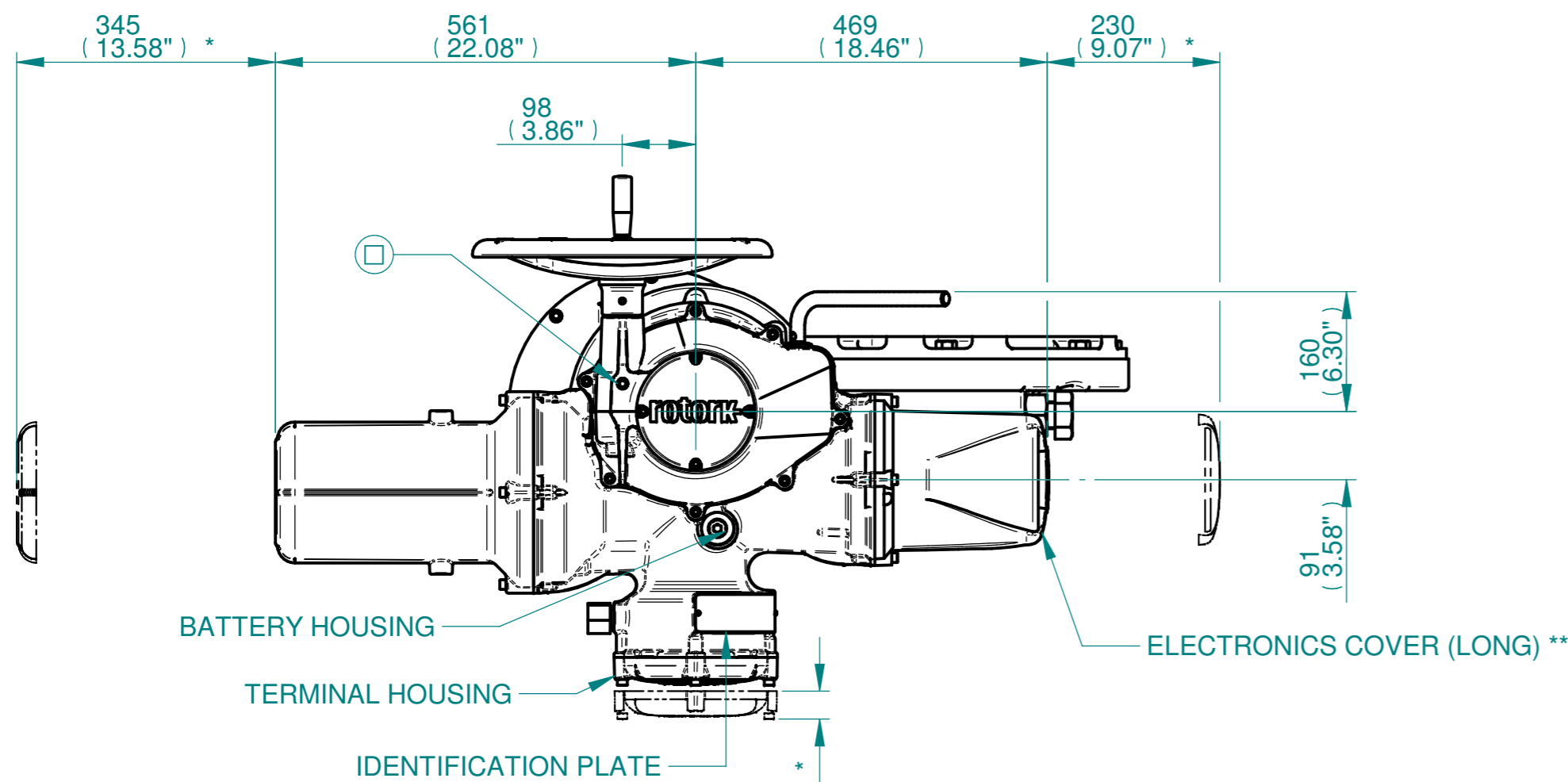
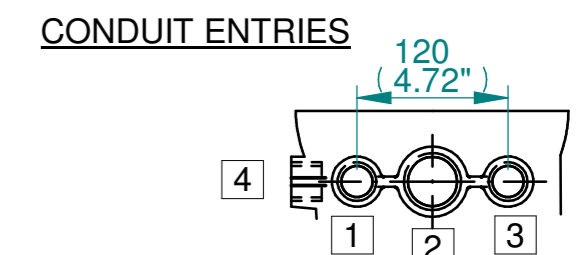

	Hole 1	Hole 2	Hole 3	Hole 4
Size	As Required	As Required	As Required	As Required
Plugged	As Required	As Required	As Required	As Required
Gland	As Required	As Required	As Required	As Required

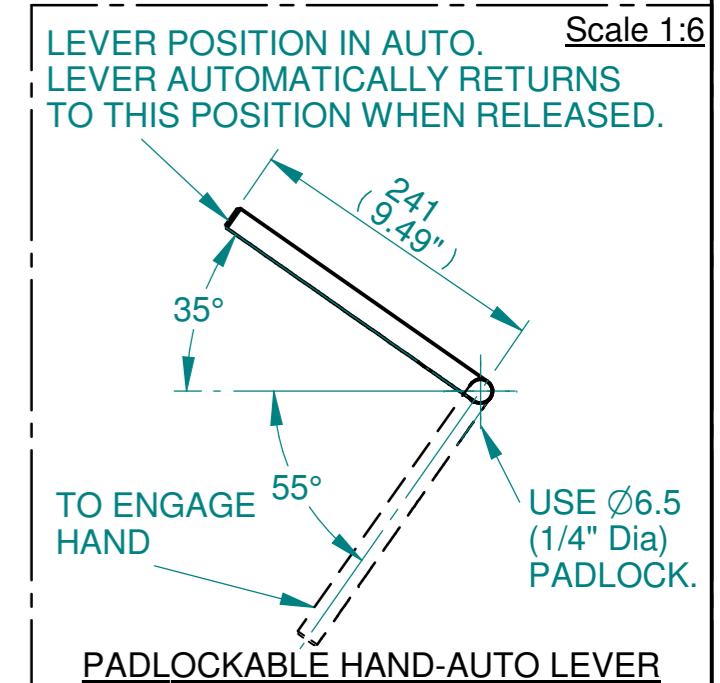
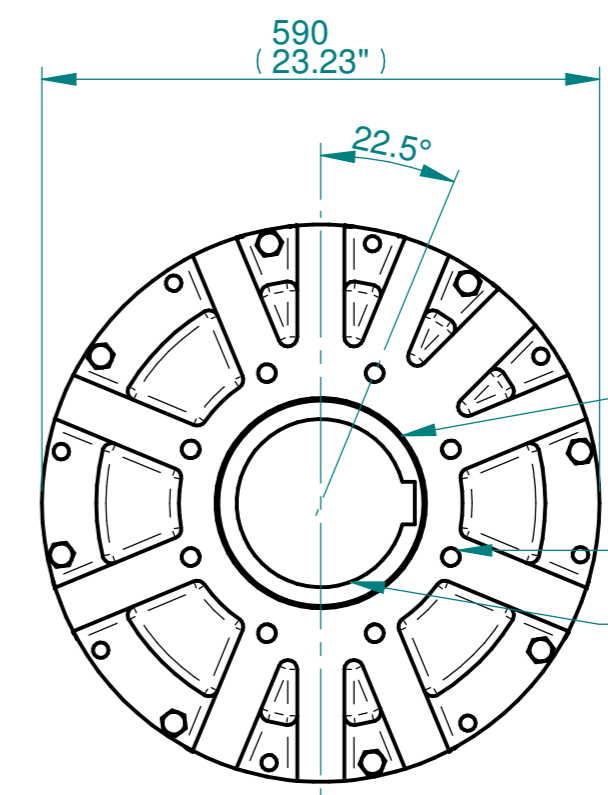
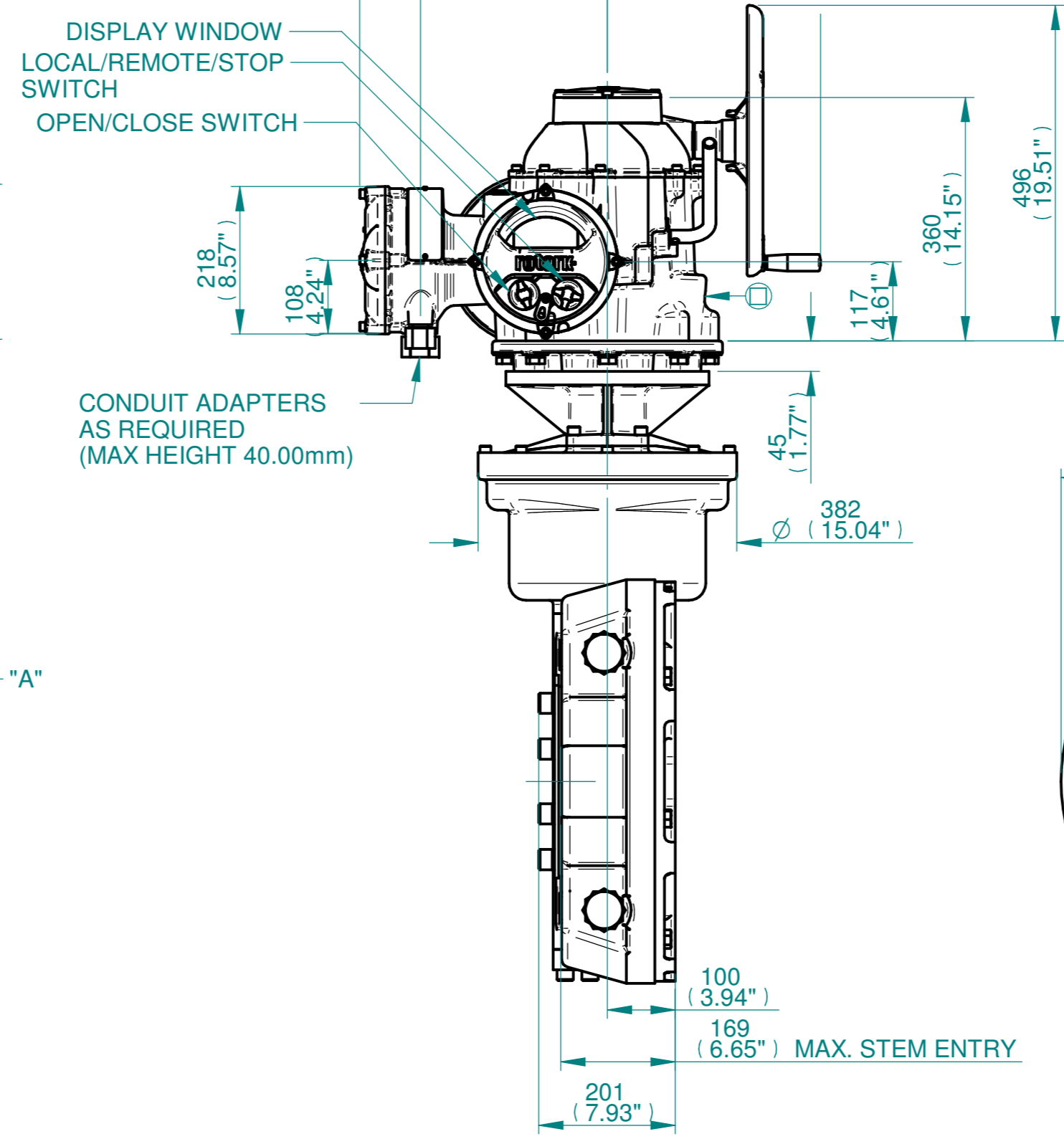
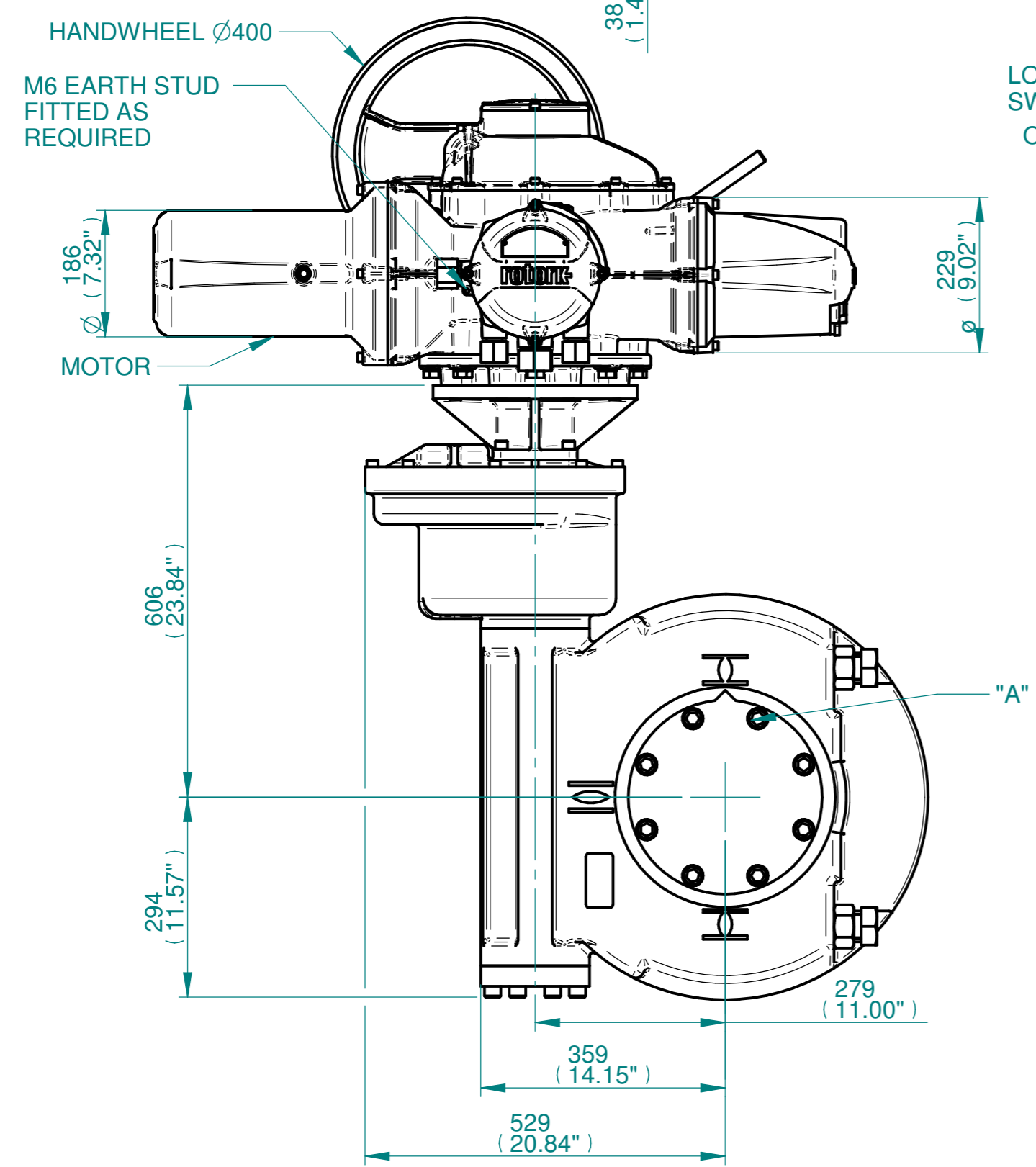

N.B. KEYWAY POS. CAN BE MOVED IN 45° STEPS BY REMOVING 8 SCREWS MARKED "A" AND ROTATING OUTPUT SLEEVE
 SEE GEARBOX OUTPUT FLANGE OPTIONS TABLE
 SEE MAXIMUM BORE & KEY TABLE

3D Models are available in various formats under the same drawing number



Rotork Controls Limited
 Bath, BA1 3JQ, England.
 Telephone 01225-733200

Actuator Size: IQ70/90/95 IW9RH/MOW9RH		Gearbox output flange options								Maximum Bore & Key			
Title	IQ70/90/95, SIDE H/W, IW9RH/MOW9RH, F30/F35/F40/FA30/FA35/FA40, Ratios 960:1 - 3000:1 Installation Details	Designation	F30	F35	F40	-	FA30	FA35	FA40	-	Key form	Ø Bore	Key size
Drawn	TED	No. Holes	8	8	8	-	8	8	8	-	Rectangle (BS4235)	178	45 X 25
Checked	NJC	Hole size	M20	M30	M36	-	3/4" UNC	1" UNC	1-1/4" UNC	-	Rectangle (ANSI B17.1)	6-1/2"	1-1/2 X 1"
Date	18-AUG-14	PCD	298	356	406	-	11.75"	14"	16"	-	Square (ANSI B17.1)	6-1/2"	1-1/2" SQ
Ref	SALES	Project Ref	QUOTATION										

Issue	Description
2	4 ENTRY CHANGE

Scale: 1:8 THIRD ANGLE PROJECTION

Drawing Number	Issue No	Sheet No
I15SHWIW9RHSTD	2	1 of 1

1 2 3 4 5 6 7 8 9 10 11 12