

1	2		3		4			5		6			7			8	
INPUT FLANGE DETAILS					MOUNTING HOLES - BOLT CIRCLE (OFF CENTRES)					STEM ACCEPTANCE IN ACCORDANCE TO STANDARD							
INPUT FLANGE	FLANGE O/DIA. + THICKNESS	SHAFT DIA.	RECESS DIA.	RECESS DEPTH	HOLE DETAILS (OFF CENTRES)	KEY DETAILS	ISO 5211 / MSS SP-101 MOUNTING OPTION	HOLE DETAILS (45° OFF CENTRES)	SPIGOT DIAMETER	MAX SCREW STEM ACCEPTANCE	STANDARD	MIN BORE	SQ KEY MAX BORE	SQ KEY SIZE	RECT. KEY MAX BORE	RECT. KEY SIZE	SQ BORE MAX
-	-	19.98-0.05 (0.787"-0.002")	-	-	-	6x6x40 (0.24"x0.24"x1.57")	F16	4 x M20 x 25 (0.98") DEEP ON Ø165.0 (Ø6.50") P.C.	Ø129.95-0.05 (Ø5.116"-0.002")	73 (2.875")	BS4235	-	-	-	68.0	20 x 12	□ 52.6 (2.071")
-	-	-	-	-	-	FA16	4 x 3/4" UNC x 25 (0.98") DEEP ON Ø165.1 (Ø6.50") P.C.	Ø126.87-0.25 (Ø4.995"-0.010")	ANSI B17.1		-	2.500"	5/8" SQ.	2.625"	5/8" x 7/16"		
-	-	-	-	-	-	-	-	-	DIN 6885		-	-	-	-	-		

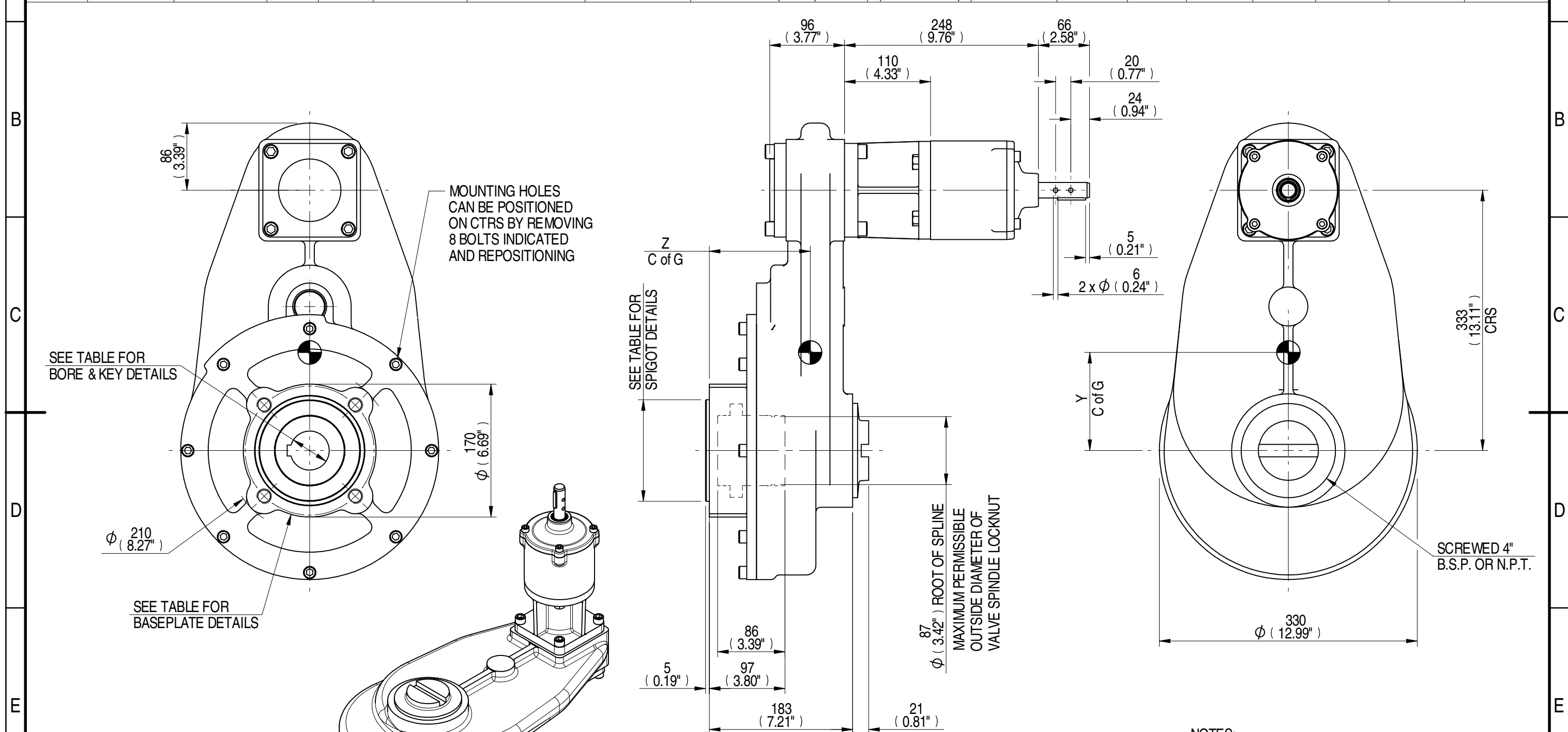

PLAN VIEW OF GEARBOX IN CLOSED POSITION SHOWING STANDARD KEYWAY POSITIONS. ALTERNATIVES AVAILABLE ON REQUEST

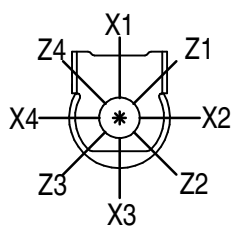

DESCRIPTION	TORQUE	CENTRE OF GRAVITY
33.2 RATIO	25.40 M.A.	72.10 WEIGHT
	2550 MAX OUTPUT	100 MAX INPUT
		0 X 126 Y 129 Z

- NOTES:
- \* THREAD DEPTH DOES NOT MATCH ISO STANDARD
  - CENTRE OF GRAVITY POSITION IS INDICATIVE FOR STANDARD BUILD WHEN IN POSITION SHOWN
  - MPR IS NOT SUITABLE FOR MOTORISED APPLICATIONS

AS PART OF CONTINUOUS PRODUCT DEVELOPMENT, ALL DETAILS SUBJECT TO CHANGE WITHOUT PRIOR NOTICE. FOR UP TO DATE DETAILS PLEASE VISIT [www.rotork.com](http://www.rotork.com)

**rotork** Gears  
LEEDS - UK  
[www.rotork.com](http://www.rotork.com)

This drawing is confidential and is the property of Rotork Gears and must not be reproduced either wholly or partly. All rights in respect of patents, designs and copyrights are reserved. © 2015

Document Type	<b>PUBLICITY</b>	Mass	72.10 kg	Title	<b>HOS8 8:1 MPR4 GEARBOX STANDARD INPUT REDUCER, F16/FA16 OUTPUT.</b>	
Created	E CHANG	20/02/2015	Dimensions in mm	Drawing Number	PUB-HOS8MPR4-33.2-MAN-F16	
Checked	J DICKINSON	13/03/2015	Scale	1:5	Iss.	01
Approved				Sheet	1 of 1	Size A3