

1	2					3			4			5			6			7		8
INPUT FLANGE DETAILS	INPUT FLANGE	FLANGE O/DIA. + THICKNESS	SHAFT DIA.	RECESS DIA.	RECESS DEPTH	HOLE DETAILS (OFF CENTRES)	KEY DETAILS	ISO 5211 / MSS SP-101 MOUNTING OPTION	HOLE DETAILS (22.5° OFF CENTRES)	SPIGOT DIAMETER	MAX SCREW STEM ACCEPTANCE	STANDARD	MIN BORE	SQ KEY MAX BORE	SQ KEY SIZE	RECT. KEY MAX BORE	RECT. KEY SIZE	SQ BORE MAX		
			19.98-0.05 (0.787"-0.002")				6x6x40 (0.24"x0.24"x1.57")	F30	8 x M20 x 25 (0.98") DEEP ON Ø298.0 (Ø11.73") P.C.	Ø229.95-0.05 (Ø9.053"-0.002")	100 (3.937")	BS4235	-	-	-	96.0	28 x 16	□ 80.9 (3.185")		
								FA30	8 x 3/4" UNC x 25 (0.98") DEEP ON Ø298.5 (Ø11.75") P.C.	Ø177.70-0.05 (Ø6.996"-0.002")		BS46	-	3.500"	7/8" SQ.	3.625"	1" x 3/4"			
												ANSI B17.1	-	3.500"	7/8" SQ.	3.750"	7/8" x 5/8"			
												DIN 6885	-	-	-	-	-			

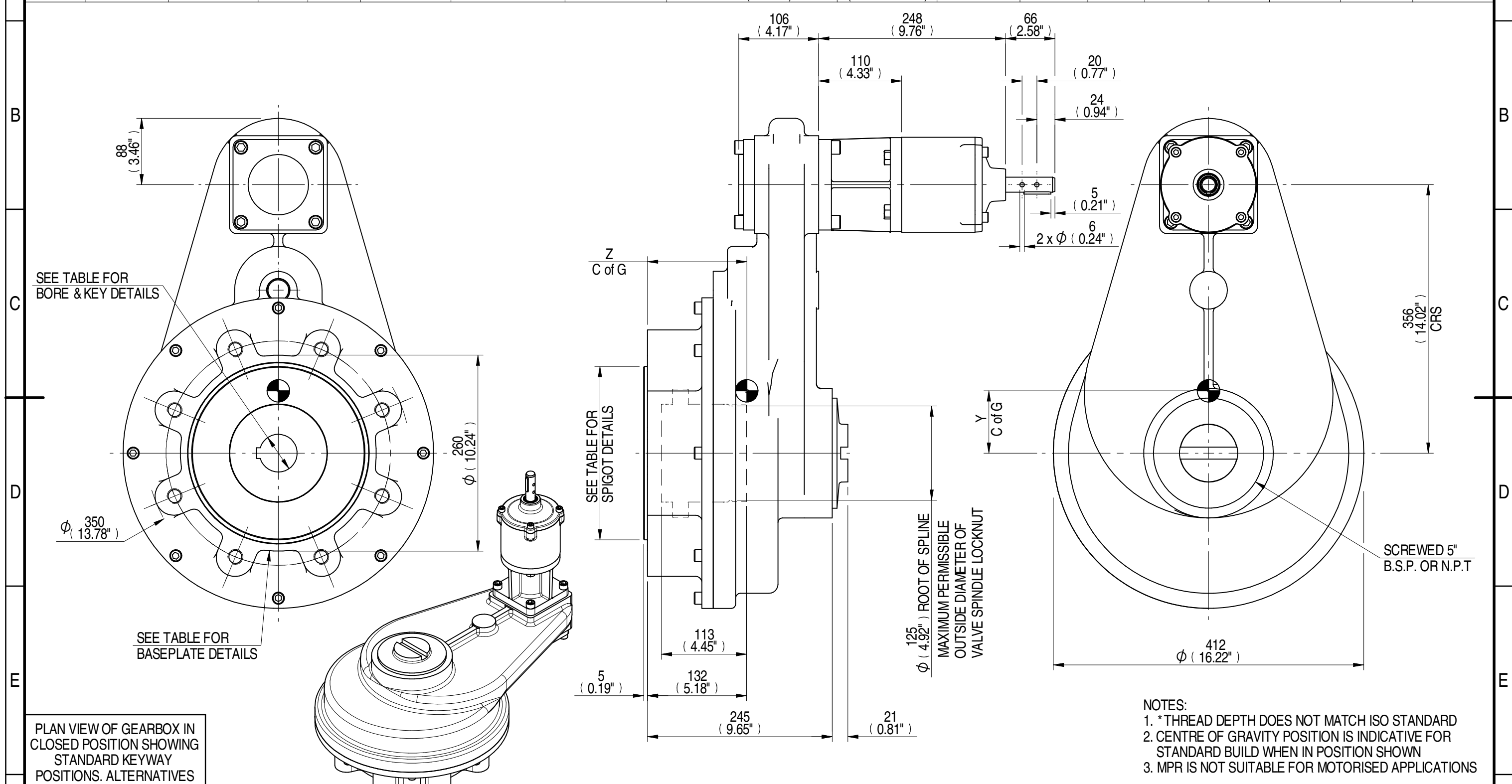

- NOTES:
- \* THREAD DEPTH DOES NOT MATCH ISO STANDARD
  - CENTRE OF GRAVITY POSITION IS INDICATIVE FOR STANDARD BUILD WHEN IN POSITION SHOWN
  - MPR IS NOT SUITABLE FOR MOTORISED APPLICATIONS

PLAN VIEW OF GEARBOX IN CLOSED POSITION SHOWING STANDARD KEYWAY POSITIONS. ALTERNATIVES AVAILABLE ON REQUEST

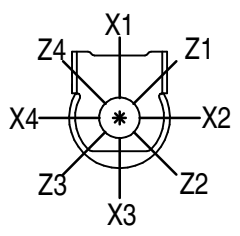

DESCRIPTION	TORQUE	CENTRE OF GRAVITY
61.3	5423	0
46.90	116	83
131.10		132
RATIO	MAX OUTPUT	MAX INPUT
M.A.		
WEIGHT		

AS PART OF CONTINUOUS PRODUCT DEVELOPMENT, ALL DETAILS SUBJECT TO CHANGE WITHOUT PRIOR NOTICE. FOR UP TO DATE DETAILS PLEASE VISIT [www.rotork.com](http://www.rotork.com)

**rotork** Gears  
LEEDS - UK  
[www.rotork.com](http://www.rotork.com)

This drawing is confidential and is the property of Rotork Gears and must not be reproduced either wholly or partly. All rights in respect of patents, designs and copyrights are reserved. © 2015

Document Type	<b>PUBLICITY</b>	Mass	131.10 kg	Title	<b>HOS11 15:1 MPR4 GEARBOX STANDARD INPUT REDUCER, F30/FA30 OUTPUT.</b>	
Created	<b>E CHANG</b>	24/02/2015	Dimensions in mm	Drawing Number	<b>PUB-HOS11MPR4-61.3-MAN-F30</b>	
Checked	<b>J DICKINSON</b>	13/03/2015	Scale	1:5	Iss.	<b>01</b>
Approved				Sheet	1 of 1	Size <b>A3</b>