

PLUG SELECTED VOLTAGE WIRE INTO  
TERMINAL "T"  
PLACE TWO REMAINING WIRES INTO  
POSITIONS "P"  
(ORDER NOT IMPORTANT)

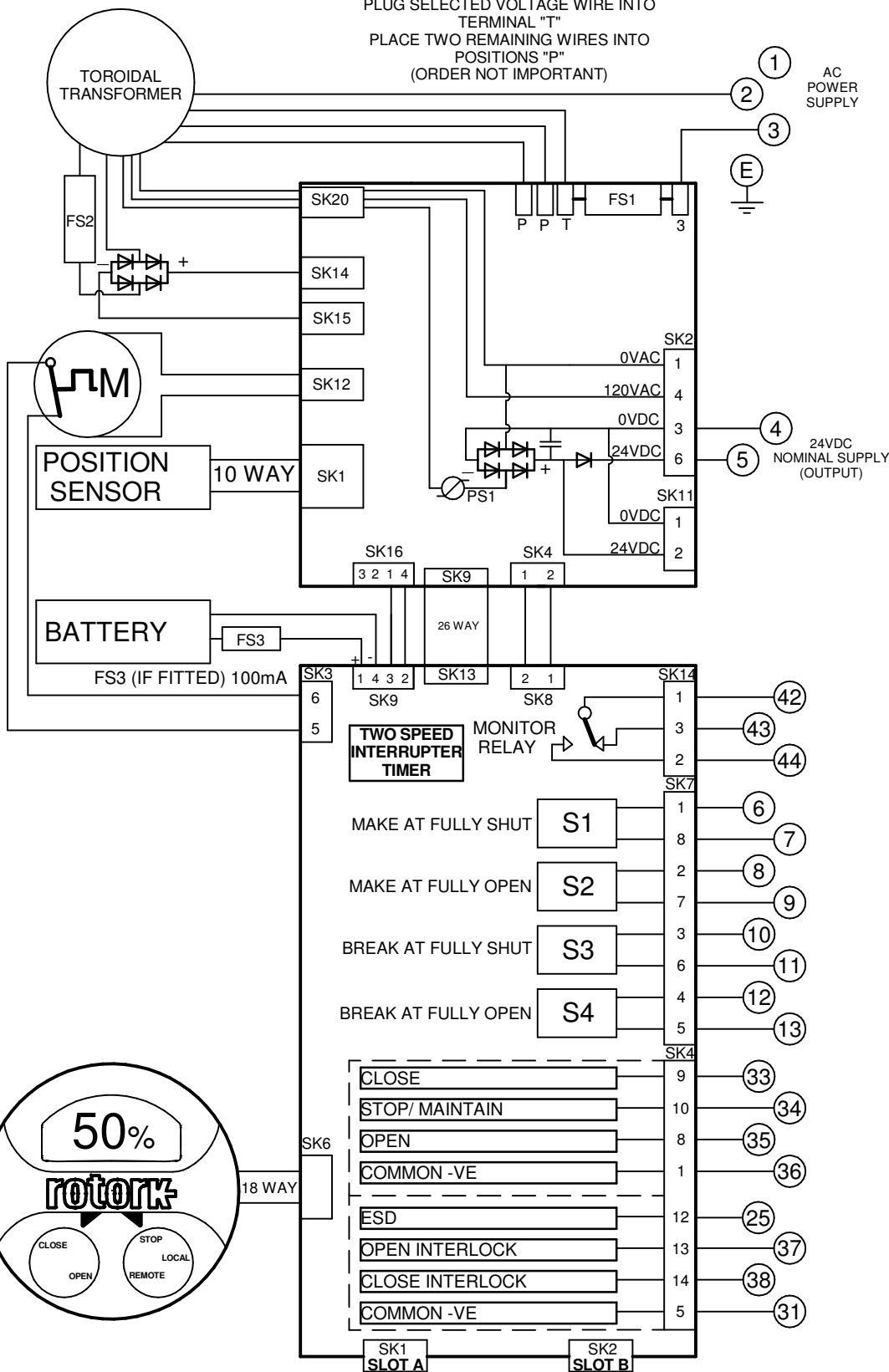

TRANSFORMER VOLTAGE OPTIONS:  
CONNECT CORRESPONDING  
COLOUR TO "T"

TYPE 1		
GREY	100V	FS1 - 5A ANTISURGE
PURPLE	110V	
BROWN	120V	
TYPE 2		
GREY	200V	FS1 - 2.5A ANTISURGE
PURPLE	230V	
BROWN	270V	
TYPE 3		
GREY	380V	FS1 - 2.0A ANTISURGE
PURPLE	400V	
BROWN	415V	
TYPE 4		
GREY	480V	FS1 - 2.0A ANTISURGE
PURPLE	575V	
BROWN	690V	

FS2 - 20A ATO FAST ACTING ALL TYPES

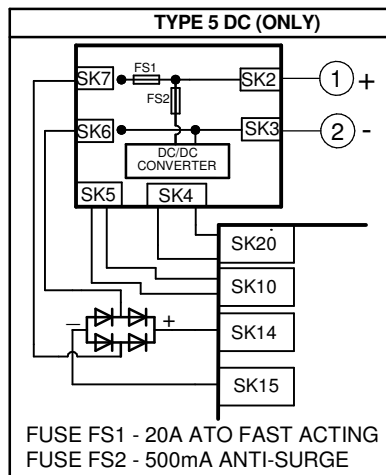

REFER TO SHEET 2 FOR NOTES  
& OPTION PCB'S IF FITTED

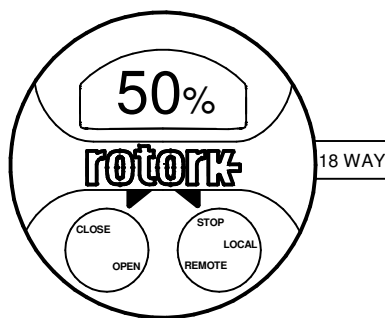

Iss	Date	Chkd	Revision Details
3	070916	PW	Updated page 2 to show correct termination SW1
4	200718 PJW	JC1	PROFIBUS PUB SHT2 UPDATED WAS PUB008-005
5	260918	DH	'TERMINATION' removed from SW1 on Sht 2.
6	180619	PMJ	PUB002-065 WAS -039

**www.rotork.com**

ROTORK CONTROLS LTD BATH, BA1 3JQ ENGLAND Tel:01225-733200	ROTORK CONTROLS INC ROCHESTER NY 14624, USA Tel:585-247-2304
---	---

IQT + TIMER + PROFIBUS SINGLE CHANNEL +  
PROFIBUS DISCONNECT

Drawn by: PJW Date : 280815 Base WD: 300P2005 Job No : -- MI No : --	Circuit Diagram Number <b>300P2005</b>	Issue No <b>6</b>	Sheet <b>1</b> of 2
--	---	----------------------	---------------------------

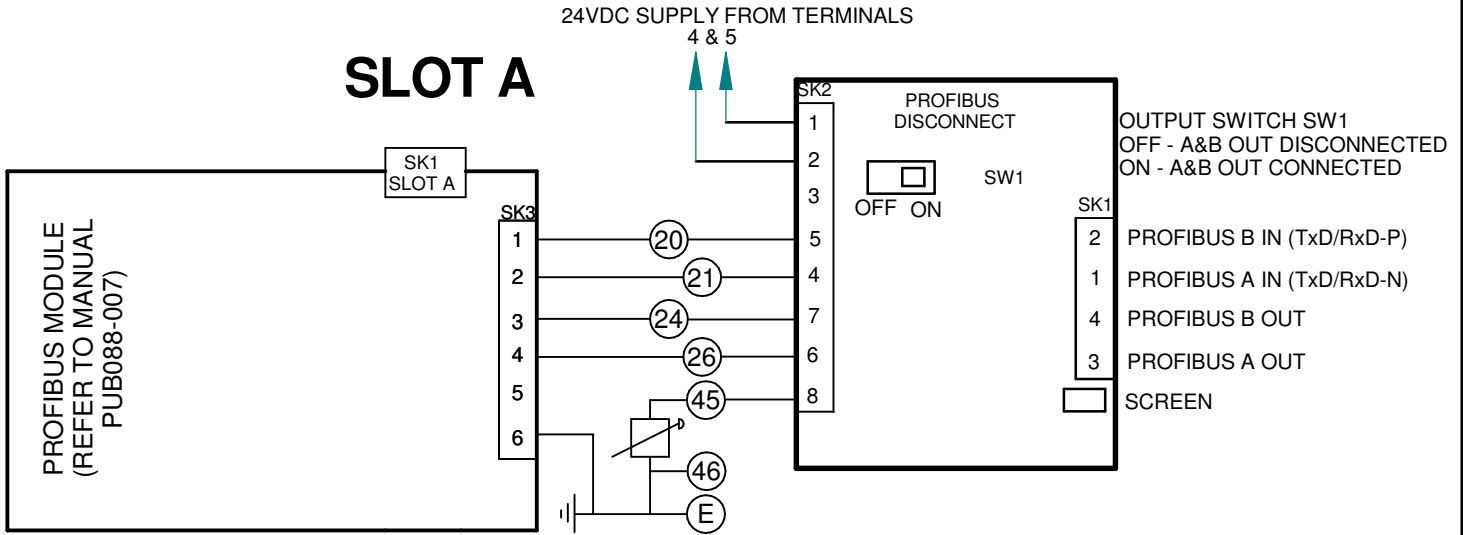

THE SETTING TOOL ENABLES THE PROFIBUS ADDRESS TO BE CONFIGURED.

**NOTES**

**1.FUSES:**

- PS1 is a self-resetting fuse.
- Refer to publication PUB002-065 for approved fuses FS1 and FS2.
- Actuator rated voltage specified on nameplate. Voltage tolerance +/-10%, applies for rated torque performance; duty cycle is not guaranteed.

**2.REMOTE CONTROL:**

- For typical remote control circuits refer to:
  - RWS indicated or PUB002-041.
- For DC and AC control, connect -ve/0V to terminal 36.
- (For negative switch / positive common, refer to RWS indicated).
- Control signal threshold voltages:
  - DC: "on" ≥16Vdc / "off" ≤8Vdc, max 60Vdc.
  - AC: "on" ≥60Vac / "off" ≤40Vac, max 120Vac.
- Control signal duration to be 300ms minimum.
- Maximum current drawn from remote control signals is:
  - 8mA at 24Vdc or 12mA at 120Vac.
- Supply provided on terminals 4 & 5:
  - Intended for remote control.
  - Max external load 5W at 24Vdc / 5VA at 120Vac

**3.INDICATION:**

- For typical position, status and alarm indication see PUB002-041.
- “S” contacts are user configurable and are shown in their default setting.
- Refer to PUB002-040 for functions and configuration instructions.
- Monitor Relay indicates actuator availability for remote control (shown “unavailable”). It can be configured to exclude local/remote selection.
- Refer to PUB002-040 for monitored functions and configuration instructions.
- Voltage applied to indication contacts must not exceed 150Vac
- Individual Switch current must not exceed 3.5A inductive, 5A resistive and no more than 8A in total for all 4 contacts.

**4.BATTERY:**

- Battery maintains local and remote “S” contact indication only.
- Refer to installation manual for approved replacement battery types.

See Sheet 1 for all Revision details/information

Circuit Diagram Number	Issue No	Sheet
<b>300P2005</b>	<b>6</b>	<b>2</b> of 2