

196.00mm [7.72in]  
74.68mm [2.94in]

SEE NOTE: 4

SEE NOTE: 3

SEE NOTE: 4

68.00mm [2.68in]

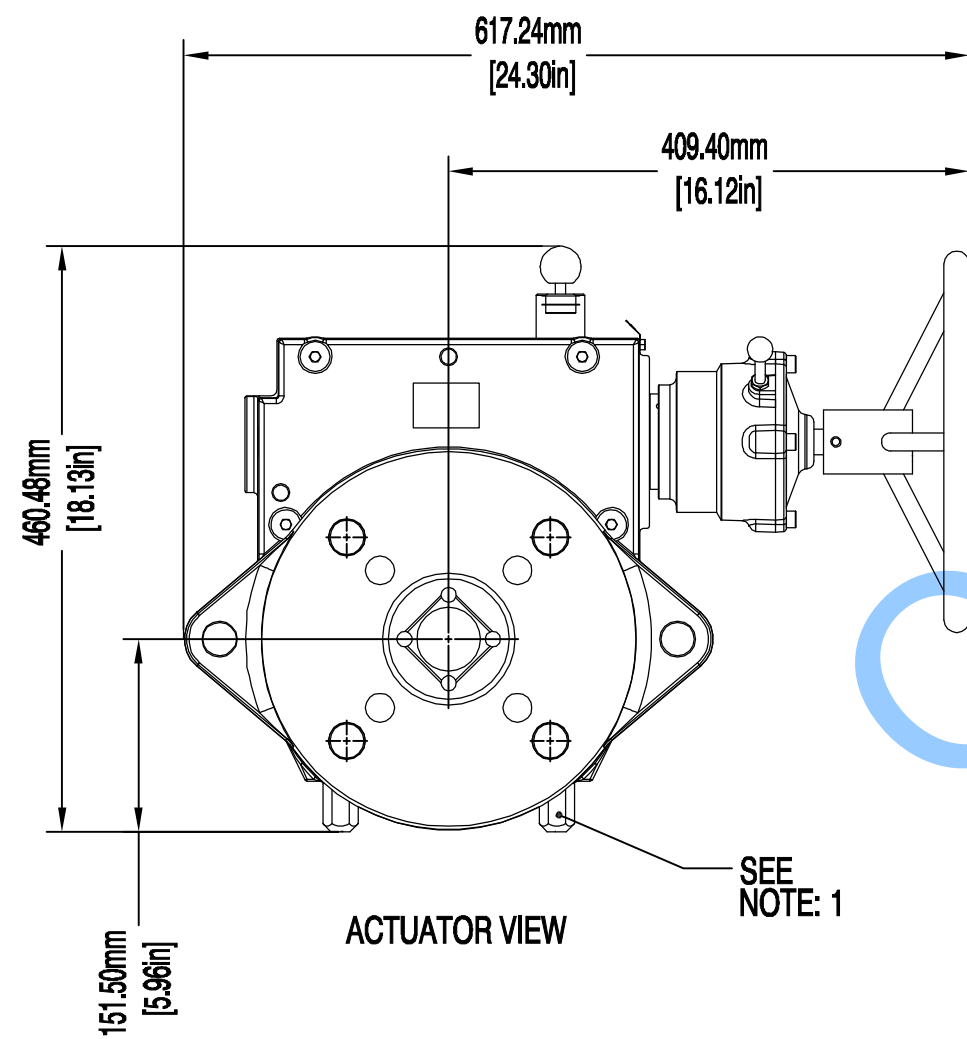

ACTUATOR VIEW

SEE NOTE: 1

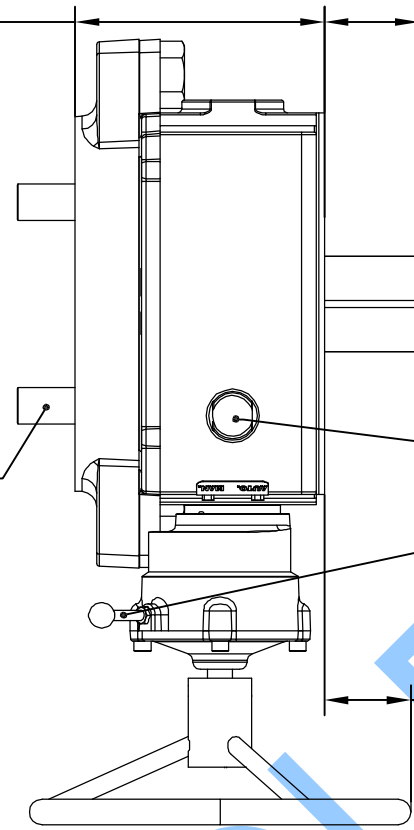

SIDE VIEW

Ø300.00mm [Ø11.81in]

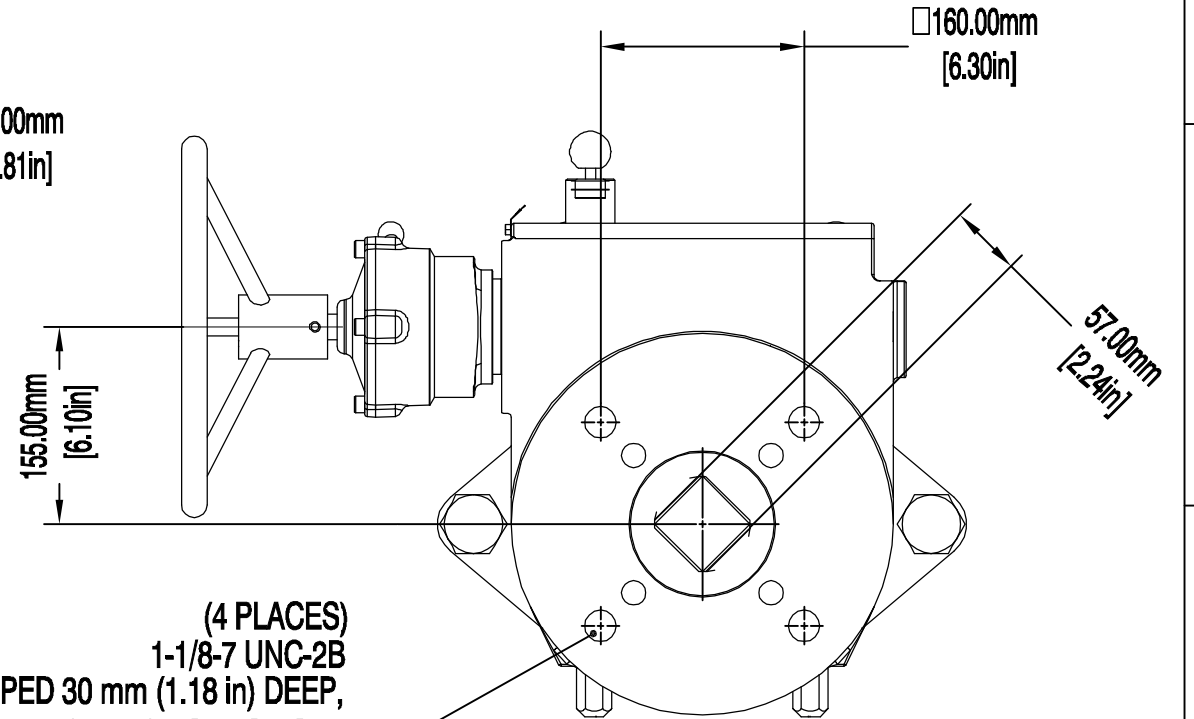

(4 PLACES)  
1-1/8-7 UNC-2B  
TAPPED 30 mm (1.18 in) DEEP,  
226.3mm (8.91in) BOLT CIRCLE  
STRADDLE  $\varnothing$

VALVE SIDE MOUNTING VIEW

- NOTES:
- 1) MECHANICAL STOPS, ADJUSTABLE
  - 2) GEAR ENGAGEMENT LEVER
  - 3) DECLUTCH PULL-PIN
  - 4) MOUNTING BOLTS TO K-6 ACTUATOR
  - 5) EST. WT. 110.22 kg (243 LB.)
  - 6) ACTUATOR MAY BE REMOVED FROM AUTOMATED VALVE WHILE GEAR REMAINS ATTACHED TO OPERATE THE VALVE OR DAMPER.
  - 7) AVAILABLE WITH ISO 5211 VALVE-SIDE MOUNT FLANGE AND FEMALE DRIVE - CONSULT K-TORK.



Texas - USA  
www.rotork.com

This drawing is confidential and is the property of Rotork Dallas Inc. and must not be reproduced either wholly or partly. All rights in respect of patents, designs and copyrights are reserved. © 2015

Document type	DETAIL DRAWING		Title	
	Dimensions in mm		K-6-HWMO - IMPERIAL MOUNTING HOLES	
	Scale 1:1		Drawing Number	
Created	S.DINESH	03-FEB-2015	D000000249	Rev 0
Checked	S.SUDHIR	03-FEB-2015		
Approved	K.PRICE	03-FEB-2015	Sheet 1 of 1	Size A3