

H
G
F
E
D
C
B
A

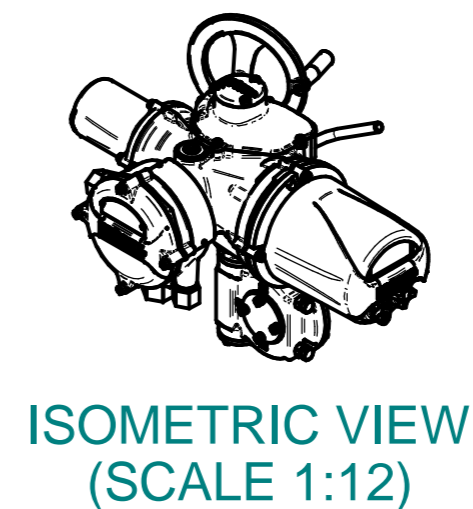

NOTES:
 : DIMENSIONS WITH "*" INDICATE COVER REMOVAL ALLOWANCE
 : ELECTRONICS COVER OPTION "****" WILL VARY DEPENDING ON CONFIGURATION
 : NETT WEIGHT = 42kg/92lbs
 : = OIL FILLER/DRAIN PLUG
 : THE INTERFACE PROVIDED FOR MOUNTING THE ACTUATOR OR SECOND STAGE GEARBOX ONTO THE VALVE SHOULD CONFORM TO GOOD ENGINEERING PRACTICES, ENSURING ADEQUATELY TOLERANCED LIMITS FOR PARALLELISM, PERPENDICULARITY AND CONCENTRICITY.
 : ROTORK CANNOT BE HELD LIABLE FOR DAMAGE TO OUR EQUIPMENT CAUSED BY EXCESSIVE LOADING FROM COVER TUBES. (SEE ALSO E156E)

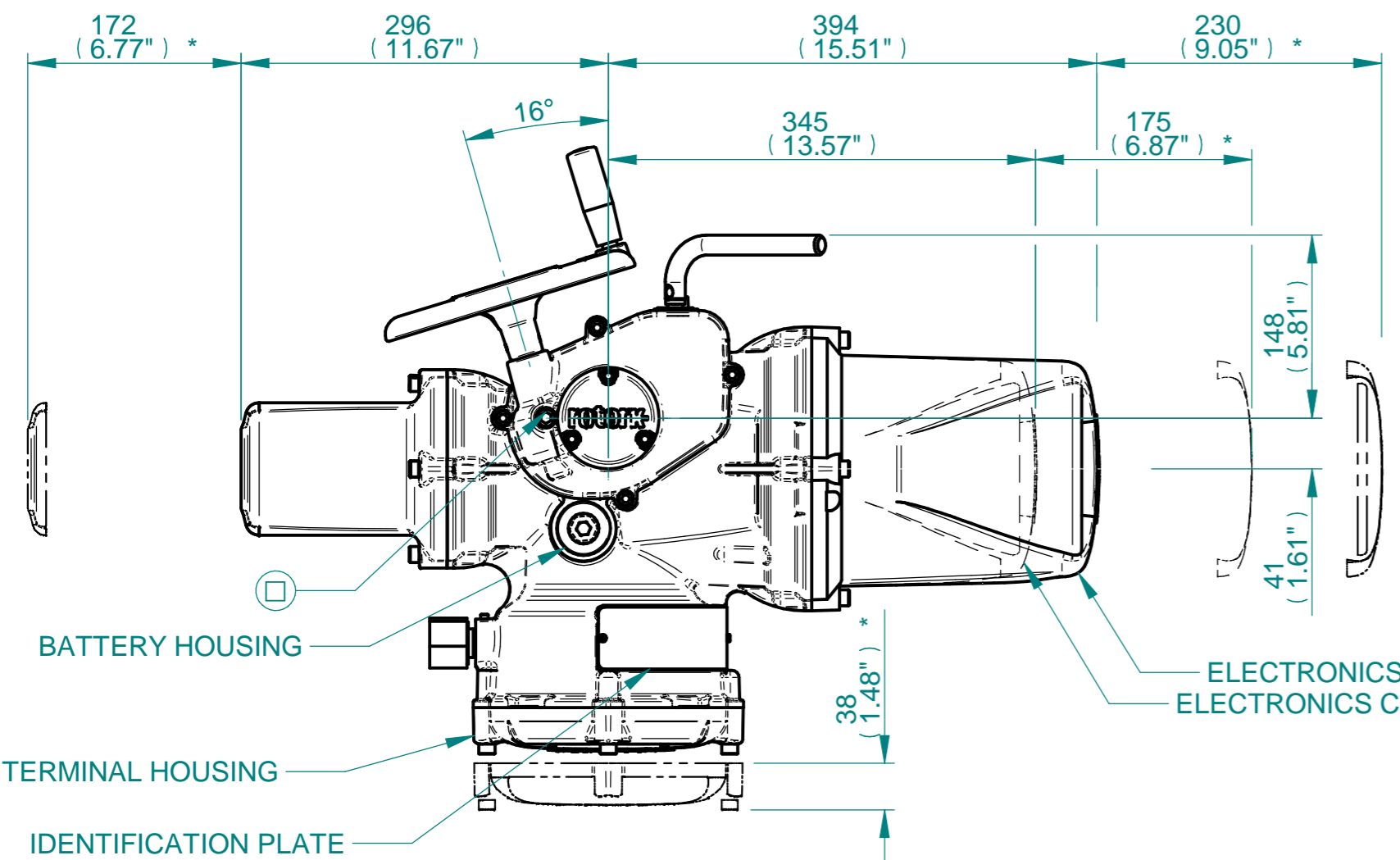
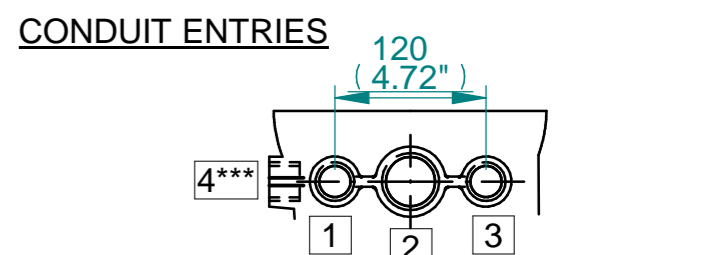

	Hole 1	Hole 2	Hole 3	Hole 4****
Size	As Required	As Required	As Required	As Required
Plugged	As Required	As Required	As Required	As Required
Gland	As Required	As Required	As Required	As Required

****HOLE 4 IS OPTIONAL

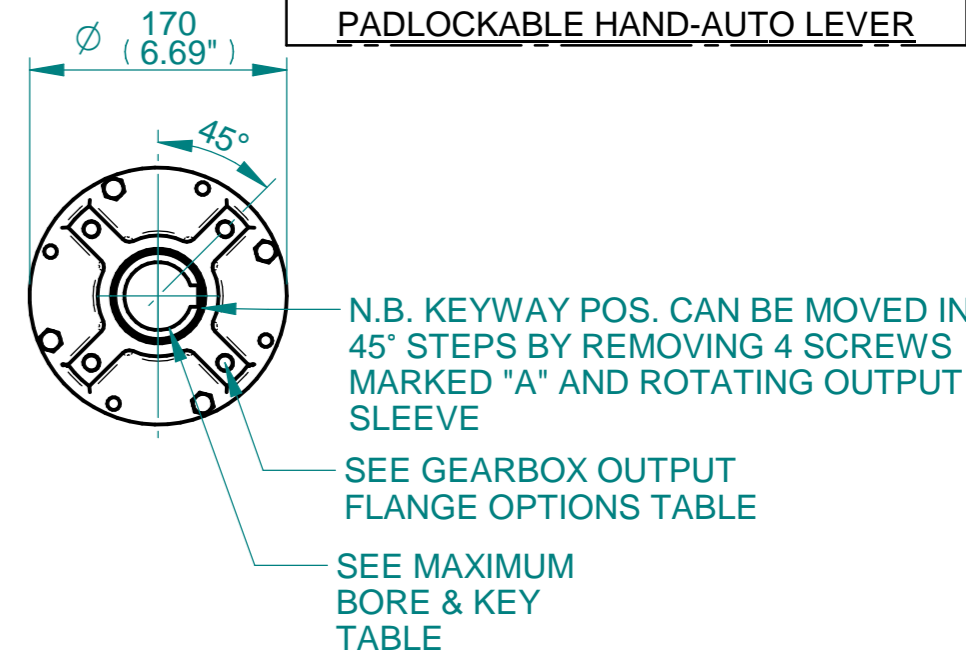
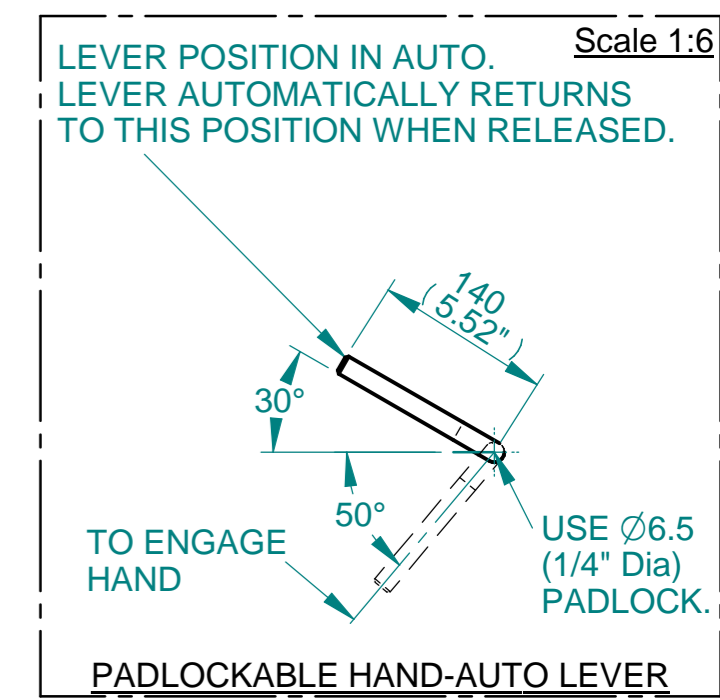
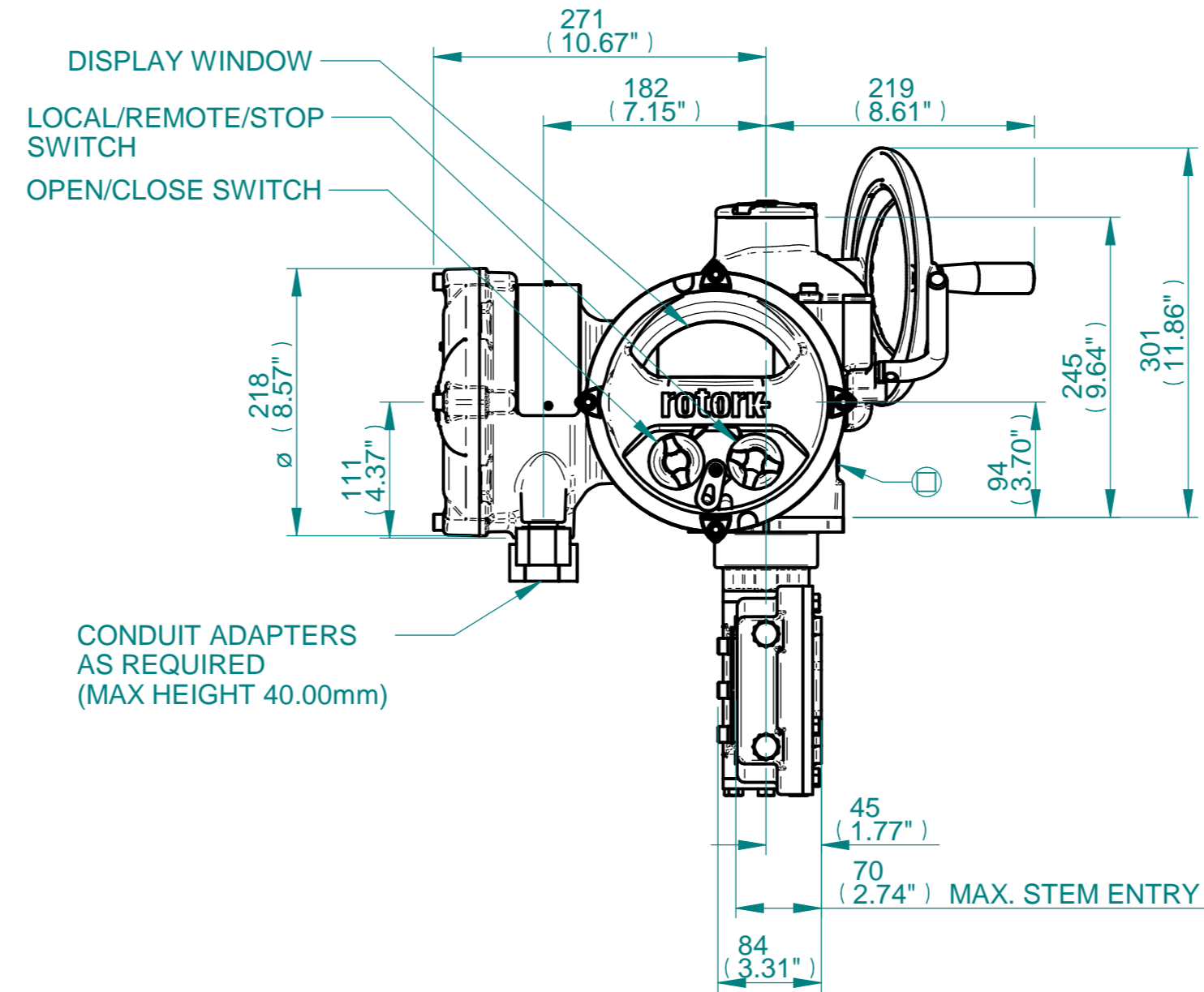
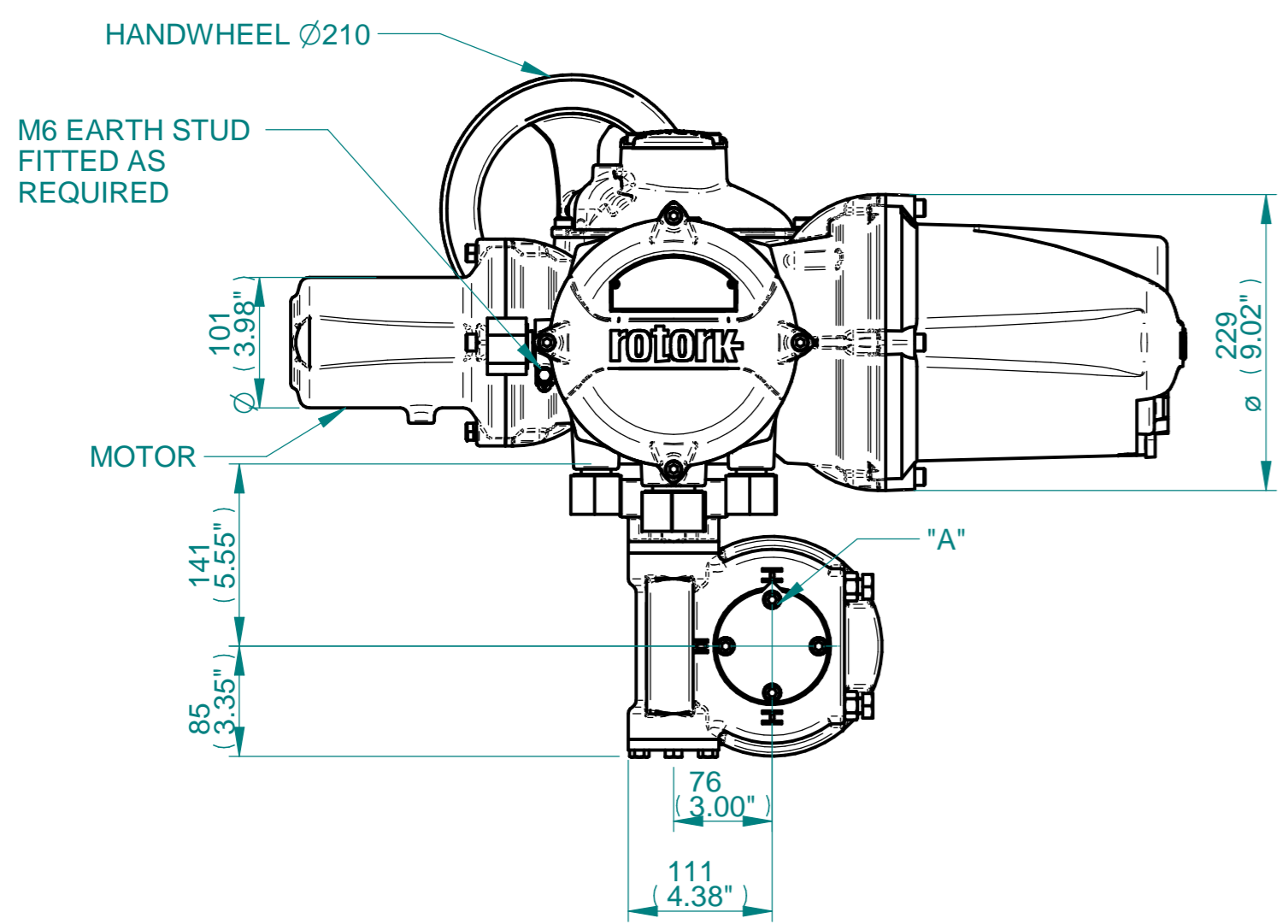

3D Models are available in various formats under the same drawing number

rotork
www.rotork.com
Rotork Controls Limited
Bath, BA1 3JQ, England.
Telephone 01225-733200

Actuator Size: IQ10/12/18 IWD3		Gearbox output flange options								Maximum Bore & Key			
Title	IQ10/12/18, SIDE HANDWHEEL, IWD3, F10/F12/FA10/FA12, Ratios 40:1 & 70:1 Installation Details	Designation	F10	F12	-	-	FA10	FA12	-	-	Key form	Ø Bore	Key size
Drawn	WJH	No. Holes	4	4	-	-	4	4	-	-	Rectangle (BS4235)	45	14 X 9
Checked	NJC	Hole size	M10	M12	-	-	3/8" UNC	1/2" UNC	-	-	Rectangle (ANSI B17.1)	1-3/4"	3/8 X 1/4"
Date	16-APR-15	PCD	102	125	-	-	4"	4.95"	-	-	Square (ANSI B17.1)	1-3/4"	3/8" SQ
Ref	SALES	Project Ref	QUOTATION										

Issue	Description
1	First Issue

Scale: 1:5 THIRD ANGLE PROJECTION

Drawing Number	Issue No	Sheet No
I11SHWIWD3STD	1	1 of 2

1 2 3 4 5 6 7 8 9 10 11 12

