

H
G
F
E
D
C
B
A

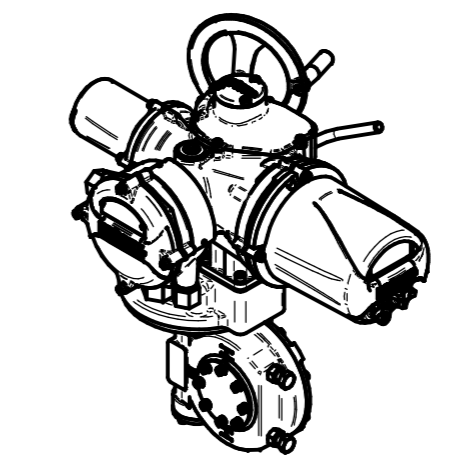
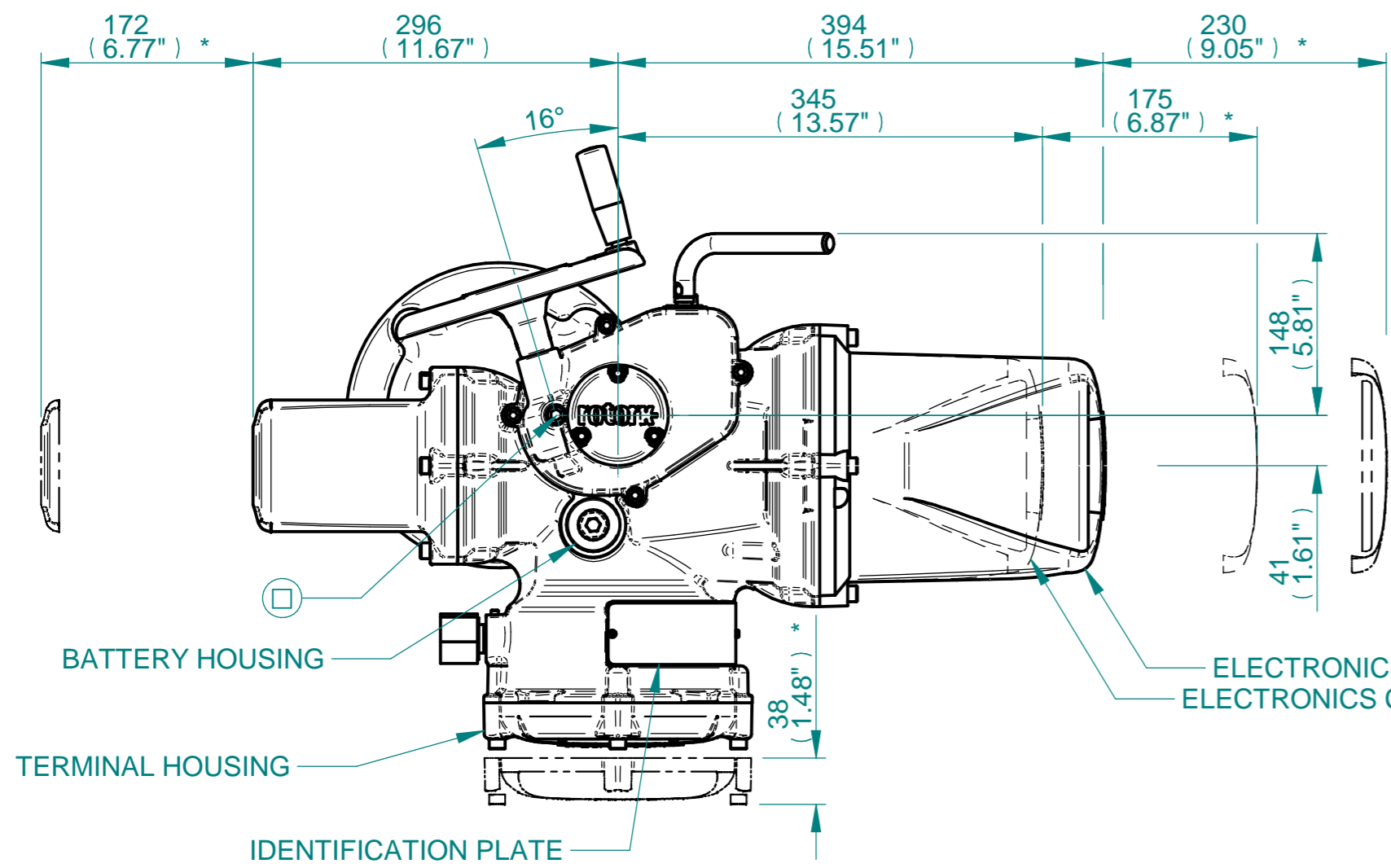

ISOMETRIC VIEW (SCALE 1:12)

NOTES:
 :DIMENSIONS WITH "*" INDICATE COVER REMOVAL ALLOWANCE
 :ELECTRONICS COVER OPTION "*" WILL VARY DEPENDING ON CONFIGURATION
 :NETT WEIGHT = 66kg/146lbs
 : = OIL FILLER/DRAIN PLUG
 :THE INTERFACE PROVIDED FOR MOUNTING THE ACTUATOR OR SECOND STAGE GEARBOX ONTO THE VALVE SHOULD CONFORM TO GOOD ENGINEERING PRACTICES, ENSURING ADEQUATELY TOLERANCED LIMITS FOR PARALLELISM, PERPENDICULARITY AND CONCENTRICITY.
 :ROTORC CANNOT BE HELD LIABLE FOR DAMAGE TO OUR EQUIPMENT CAUSED BY EXCESSIVE LOADING FROM COVER TUBES. (SEE ALSO E156E)

CONDUIT ENTRIES

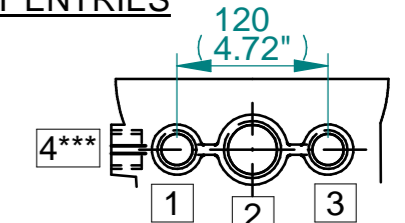

	Hole 1	Hole 2	Hole 3	Hole 4***
Size	As Required	As Required	As Required	As Required
Plugged	As Required	As Required	As Required	As Required
Gland	As Required	As Required	As Required	As Required

***HOLE 4 IS OPTIONAL

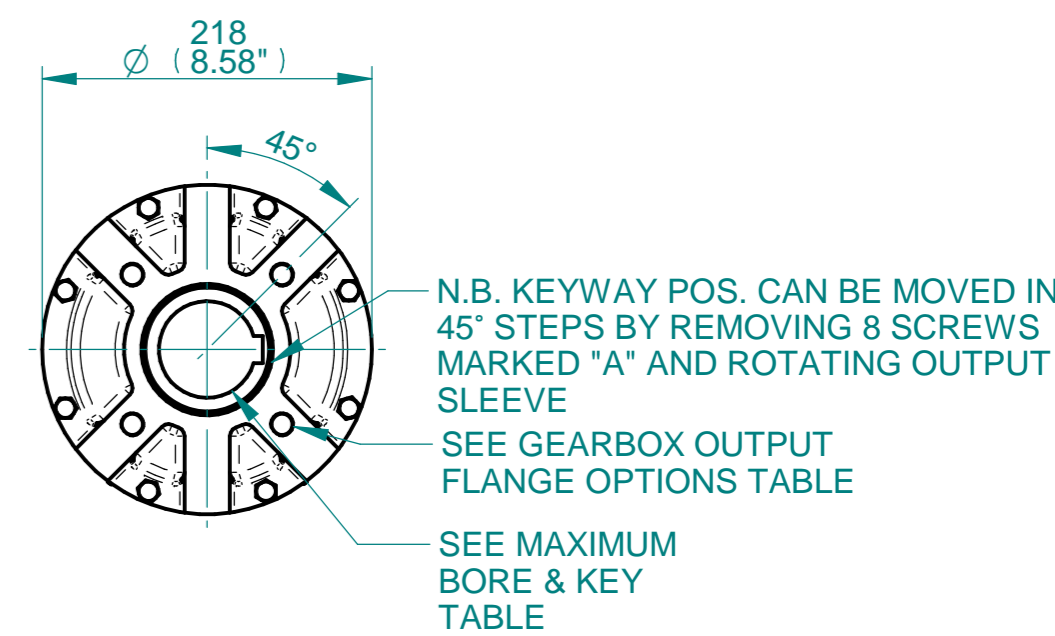
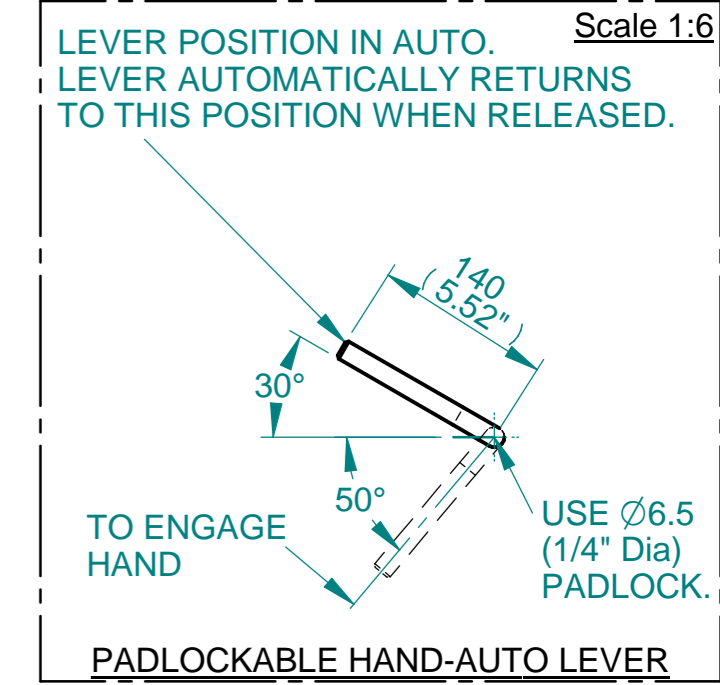
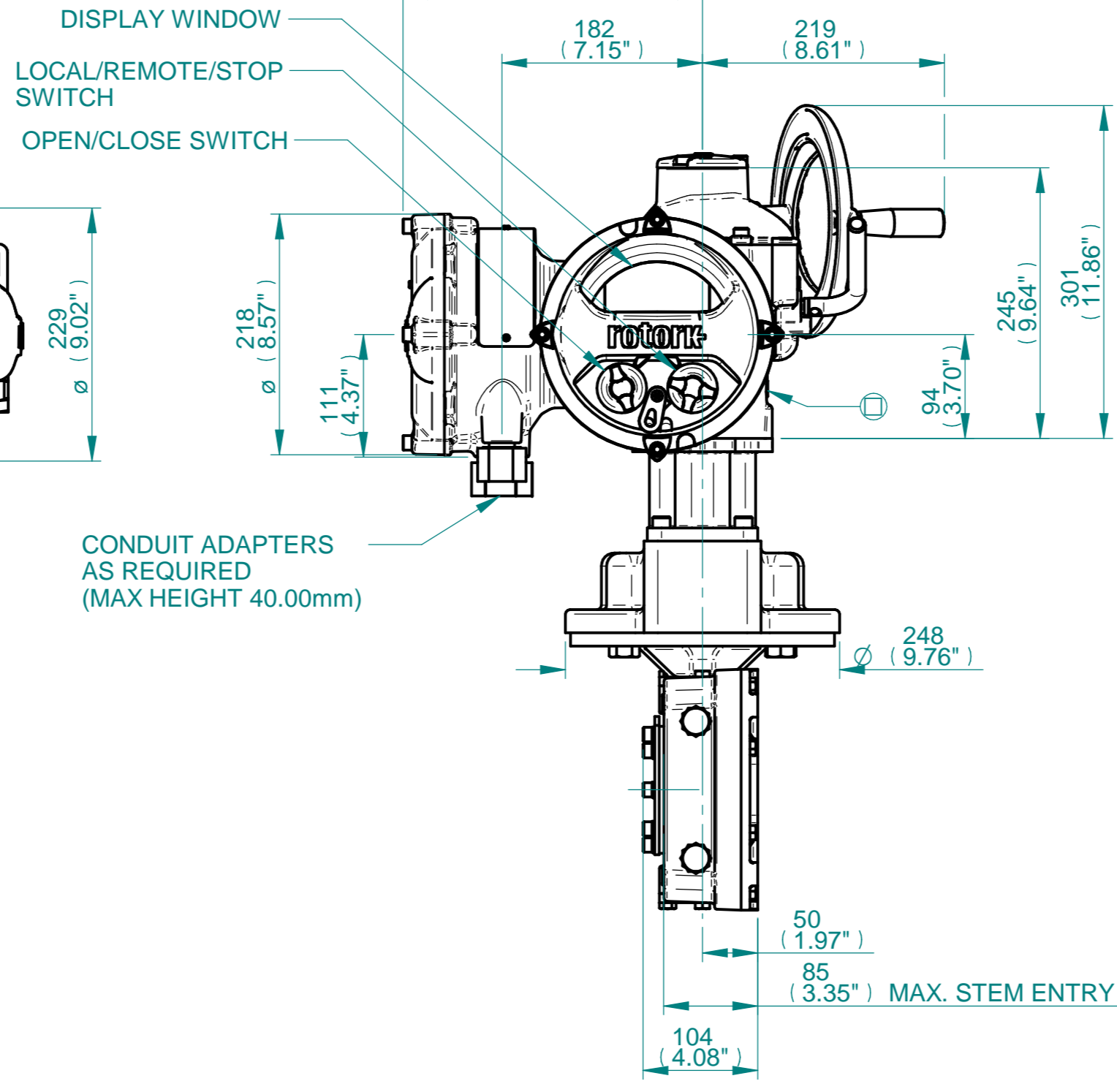
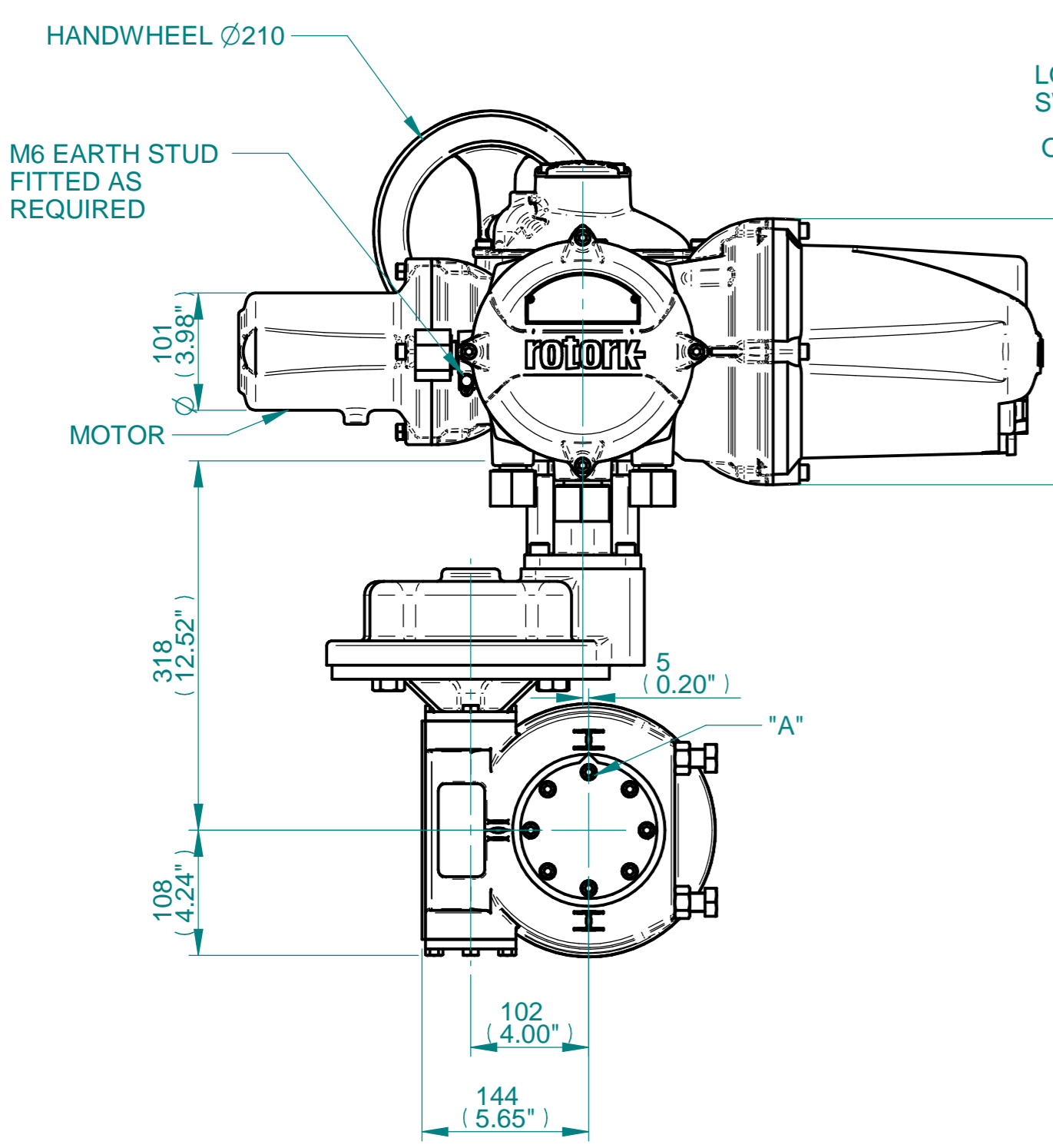

3D Models are available in various formats under the same drawing number

rotork
 www.rotork.com
 Rotork Controls Limited
 Bath, BA1 3JQ, England.
 Telephone 01225-733200

Actuator Size: IQ10/12/18 IWD4RH		Gearbox output flange options								Maximum Bore & Key			
Title	IQ10/12/18, SIDE HANDWHEEL, IWD4RH, F12/F14/FA12/FA14, Ratios 200:1, 240:1, 350:1 & 420:1 Installation Details	Designation	F12	F14	-	-	FA12	FA14	-	-	Key form	Ø Bore	Key size
Drawn	WJH	No. Holes	4	4	-	-	4	4	-	-	Rectangle (BS4235)	64	18 X 11
Checked	NJC	Hole size	M12	M16	-	-	1/2" UNC	5/8" UNC	-	-	Rectangle (ANSI B17.1)	2-1/2"	5/8 X 7/16"
Date	16-APR-15	PCD	125	140	-	-	4.95"	5.5"	-	-	Square (ANSI B17.1)	2-1/4"	1/2" SQ
Ref	SALES	Project Ref QUOTATION											

Issue	Description
1	First Issue

Scale: 1:5 THIRD ANGLE PROJECTION

Drawing Number	Issue No	Sheet No
I11SHWIWD4RHSTD	1	1 of 1

1 2 3 4 5 6 7 8 9 10 11 12