

H
G
F
E
D
C
B
A

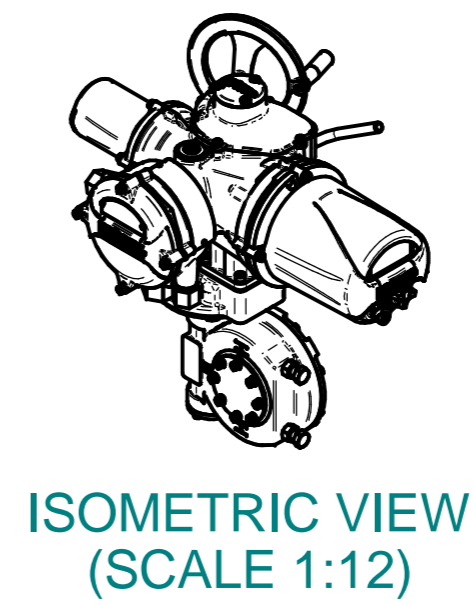

NOTES:
 : DIMENSIONS WITH "*" INDICATE COVER REMOVAL ALLOWANCE
 : ELECTRONICS COVER OPTION "****" WILL VARY DEPENDING ON CONFIGURATION
 : NETT WEIGHT = 61kg/134lbs
 : = OIL FILLER/DRAIN PLUG
 : THE INTERFACE PROVIDED FOR MOUNTING THE ACTUATOR OR SECOND STAGE GEARBOX ONTO THE VALVE SHOULD CONFORM TO GOOD ENGINEERING PRACTICES, ENSURING ADEQUATELY TOLERANCED LIMITS FOR PARALLELISM, PERPENDICULARITY AND CONCENTRICITY.
 : ROTORK CANNOT BE HELD LIABLE FOR DAMAGE TO OUR EQUIPMENT CAUSED BY EXCESSIVE LOADING FROM COVER TUBES. (SEE ALSO E156E)

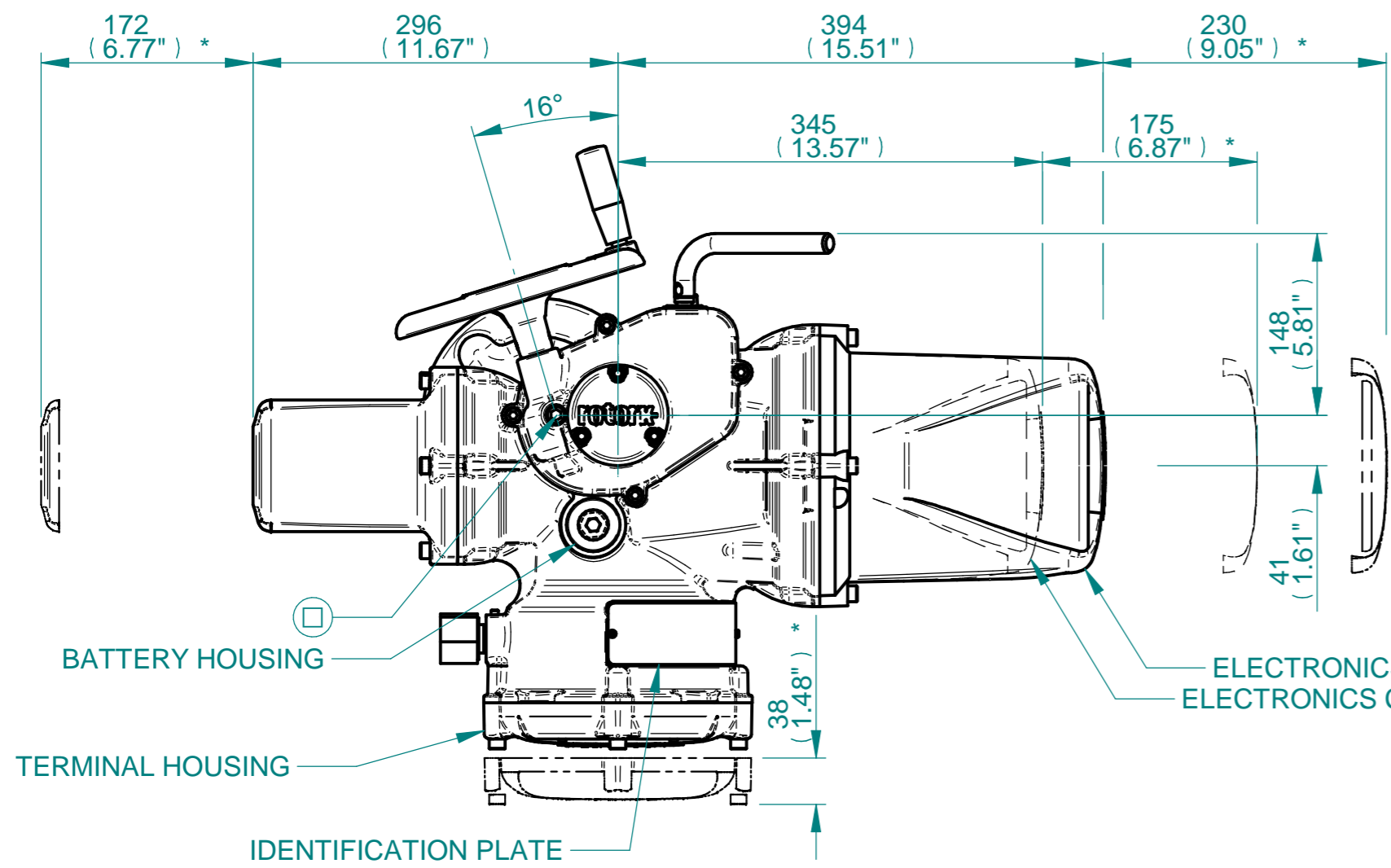
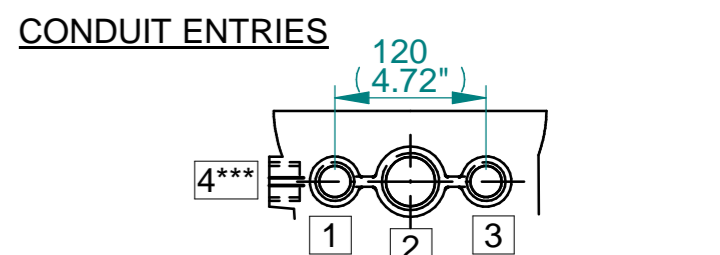

	Hole 1	Hole 2	Hole 3	Hole 4***
Size	As Required	As Required	As Required	As Required
Plugged	As Required	As Required	As Required	As Required
Gland	As Required	As Required	As Required	As Required

***HOLE 4 IS OPTIONAL

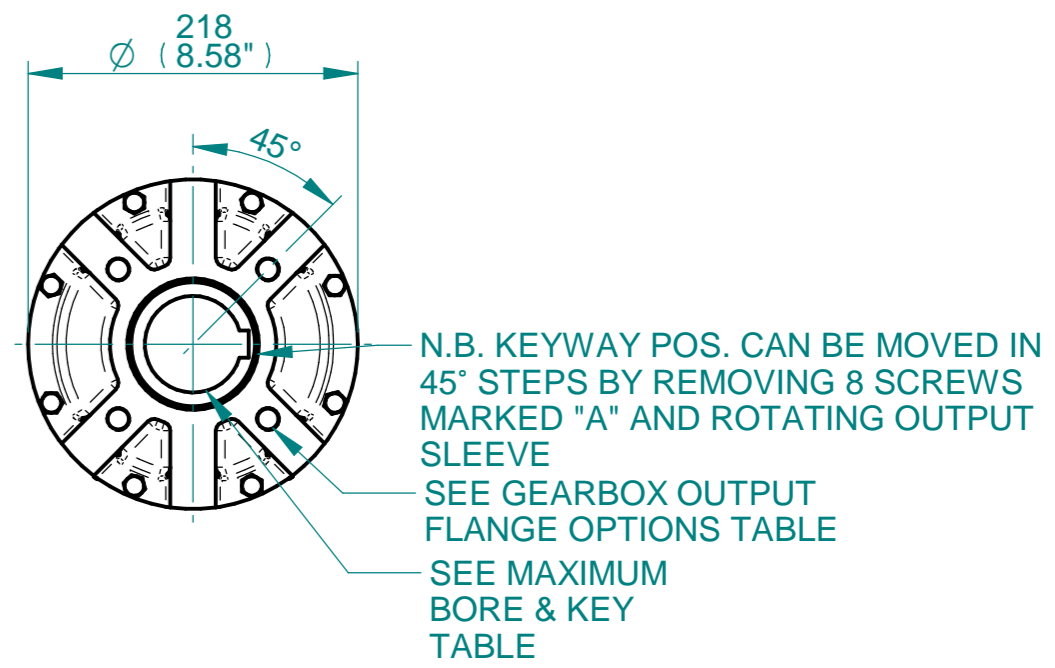
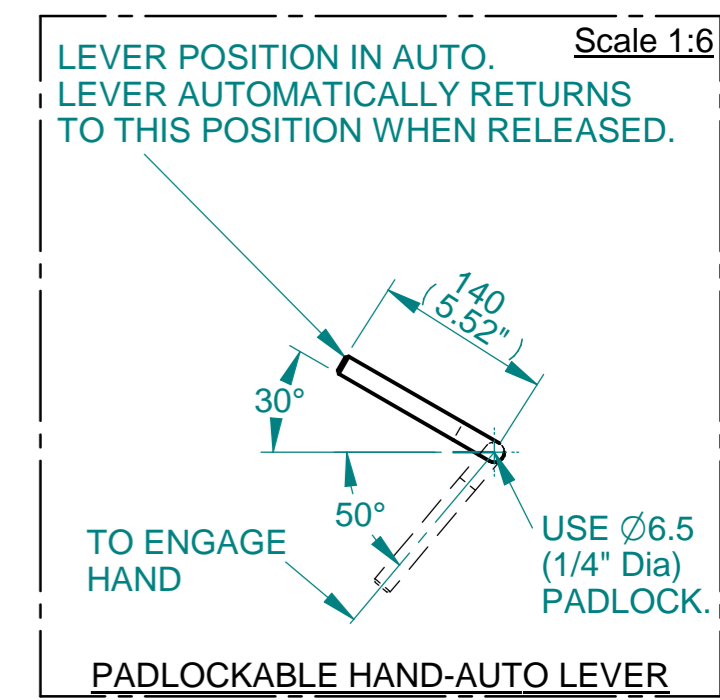
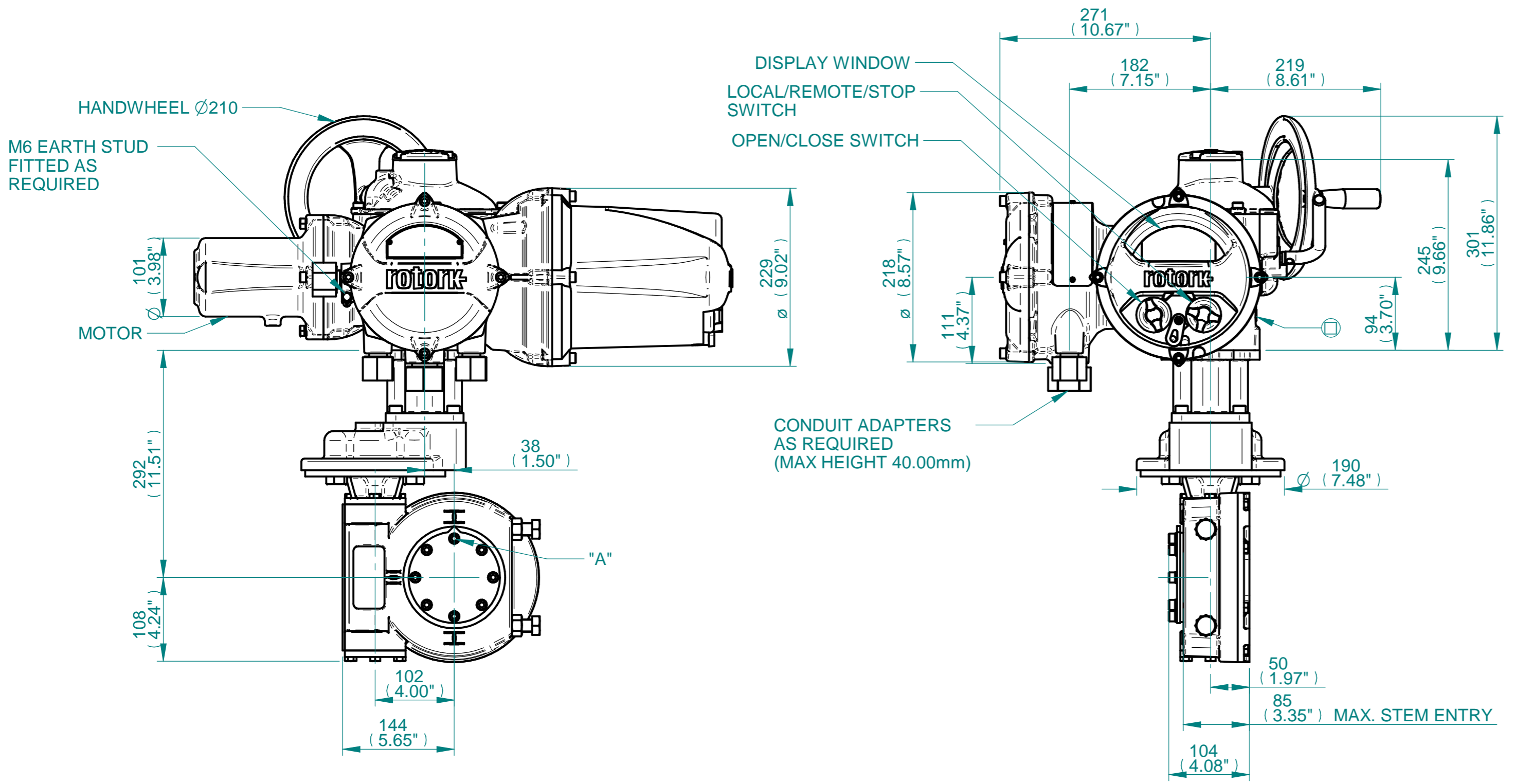

3D Models are available in various formats under the same drawing number

rotork
 www.rotork.com
 Rotork Controls Limited
 Bath, BA1 3JQ, England.
 Telephone 01225-733200

Actuator Size: IQ10/12/18 IWD4RL		Gearbox output flange options								Maximum Bore & Key			
Title	IQ10/12/18, SIDE HANDWHEEL, IWD4RL, F12/F14FA12/FA14, Ratios 80:1 - 160:1 & 210:1 & 280:1 Installation Details	Designation	F12	F14	-	-	FA12	FA14	-	-	Key form	Ø Bore	Key size
Drawn	WJH	No. Holes	4	4	-	-	4	4	-	-	Rectangle (BS4235)	64	18 X 11
Checked	NJC	Hole size	M12	M16	-	-	1/2" UNC	5/8" UNC	-	-	Rectangle (ANSI B17.1)	2-1/2"	5/8 X 7/16"
Date	16-APR-15	PCD	125	140	-	-	4.95"	5.5"	-	-	Square (ANSI B17.1)	2-1/4"	1/2" SQ
Ref	SALES Project Ref QUOTATION												

Issue	Description
1	First Issue

Scale: 1:5 THIRD ANGLE PROJECTION

Drawing Number	Issue No	Sheet No
I11SHWIWD4RLSTD	1	1 of 1

1 2 3 4 5 6 7 8 9 10 11 12