

H
G
F
E
D
C
B
A

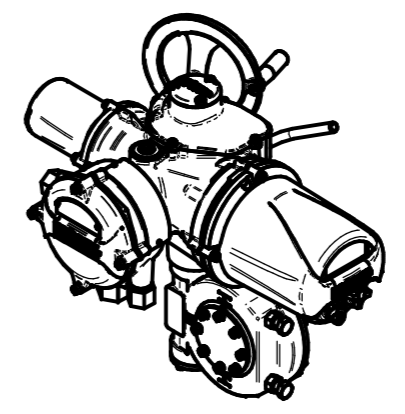
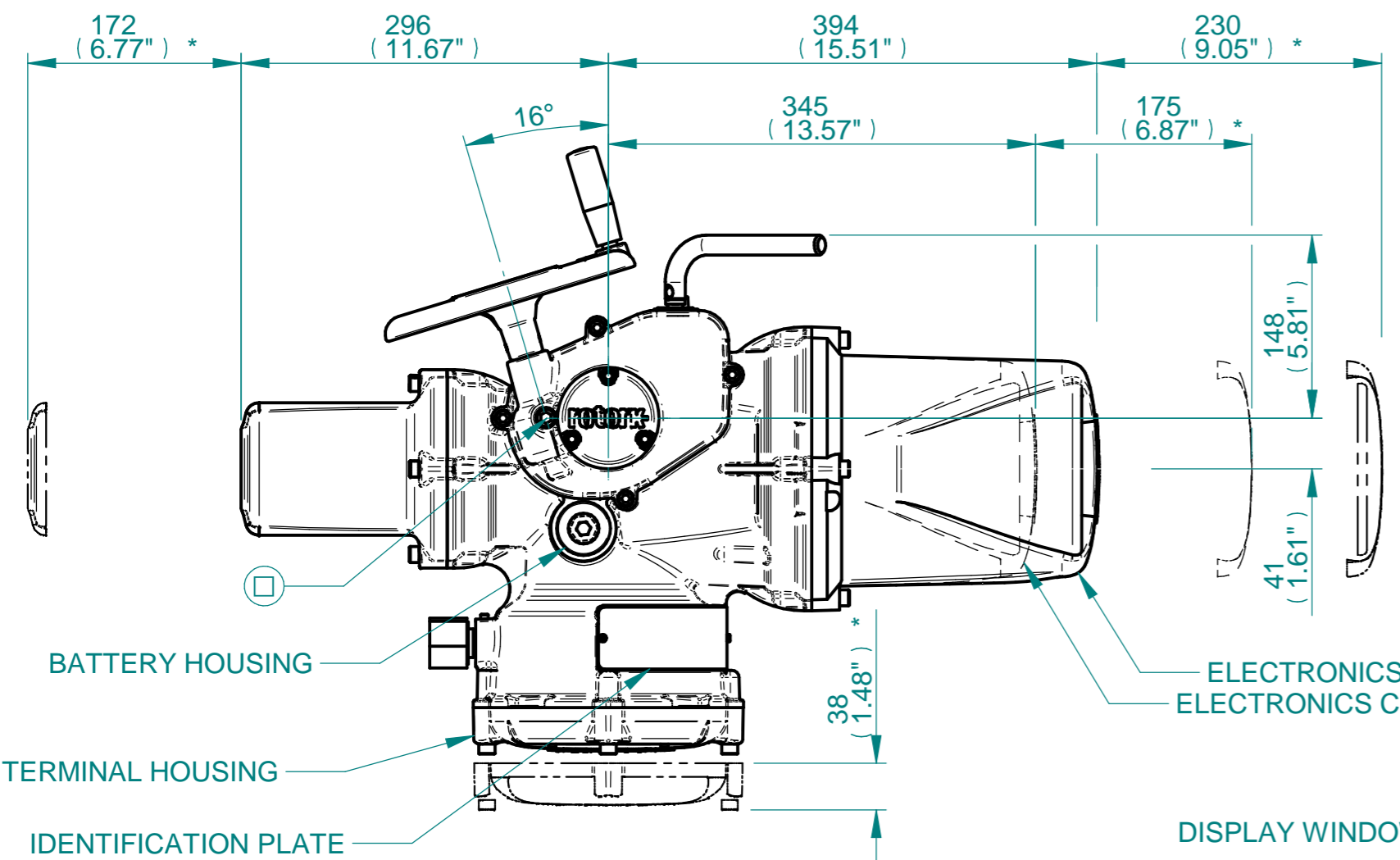

ISOMETRIC VIEW
(SCALE 1:12)

NOTES:
 :DIMENSIONS WITH "*" INDICATE COVER REMOVAL ALLOWANCE
 :ELECTRONICS COVER OPTION "****" WILL VARY DEPENDING ON CONFIGURATION
 :NETT WEIGHT = 53kg/117lbs
 : = OIL FILLER/DRAIN PLUG
 :THE INTERFACE PROVIDED FOR MOUNTING THE ACTUATOR OR SECOND STAGE GEARBOX ONTO THE VALVE SHOULD CONFORM TO GOOD ENGINEERING PRACTICES, ENSURING ADEQUATELY TOLERANCED LIMITS FOR PARALLELISM, PERPENDICULARITY AND CONCENTRICITY.
 :ROTORK CANNOT BE HELD LIABLE FOR DAMAGE TO OUR EQUIPMENT CAUSED BY EXCESSIVE LOADING FROM COVER TUBES. (SEE ALSO E156E)

CONDUIT ENTRIES

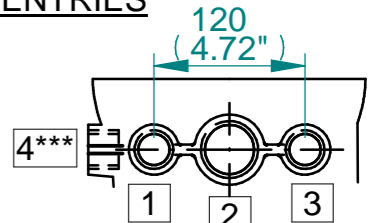

	Hole 1	Hole 2	Hole 3	Hole 4***
Size	As Required	As Required	As Required	As Required
Plugged	As Required	As Required	As Required	As Required
Gland	As Required	As Required	As Required	As Required

***HOLE 4 IS OPTIONAL

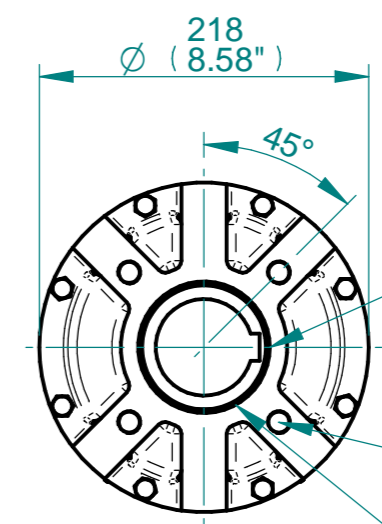
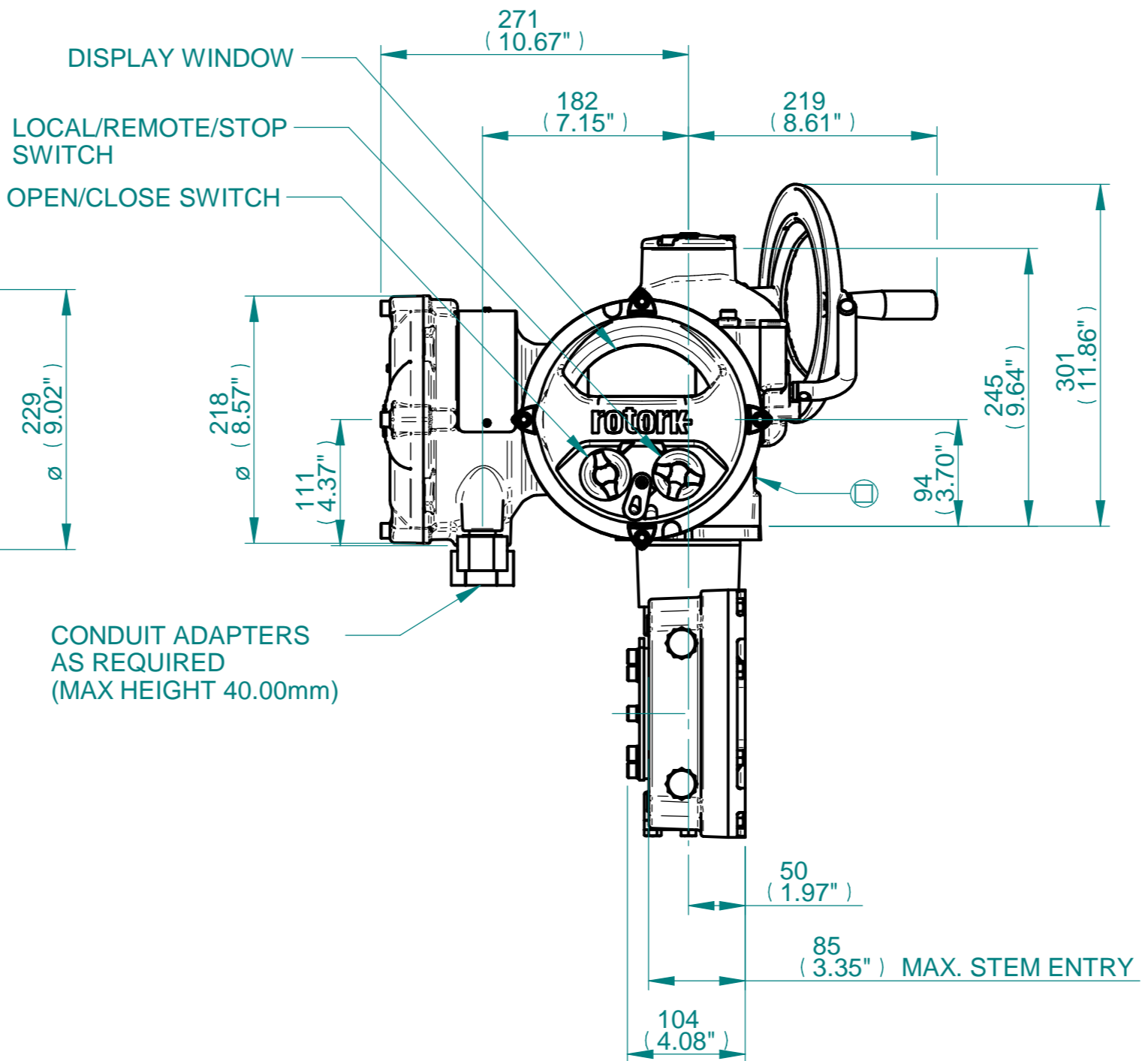
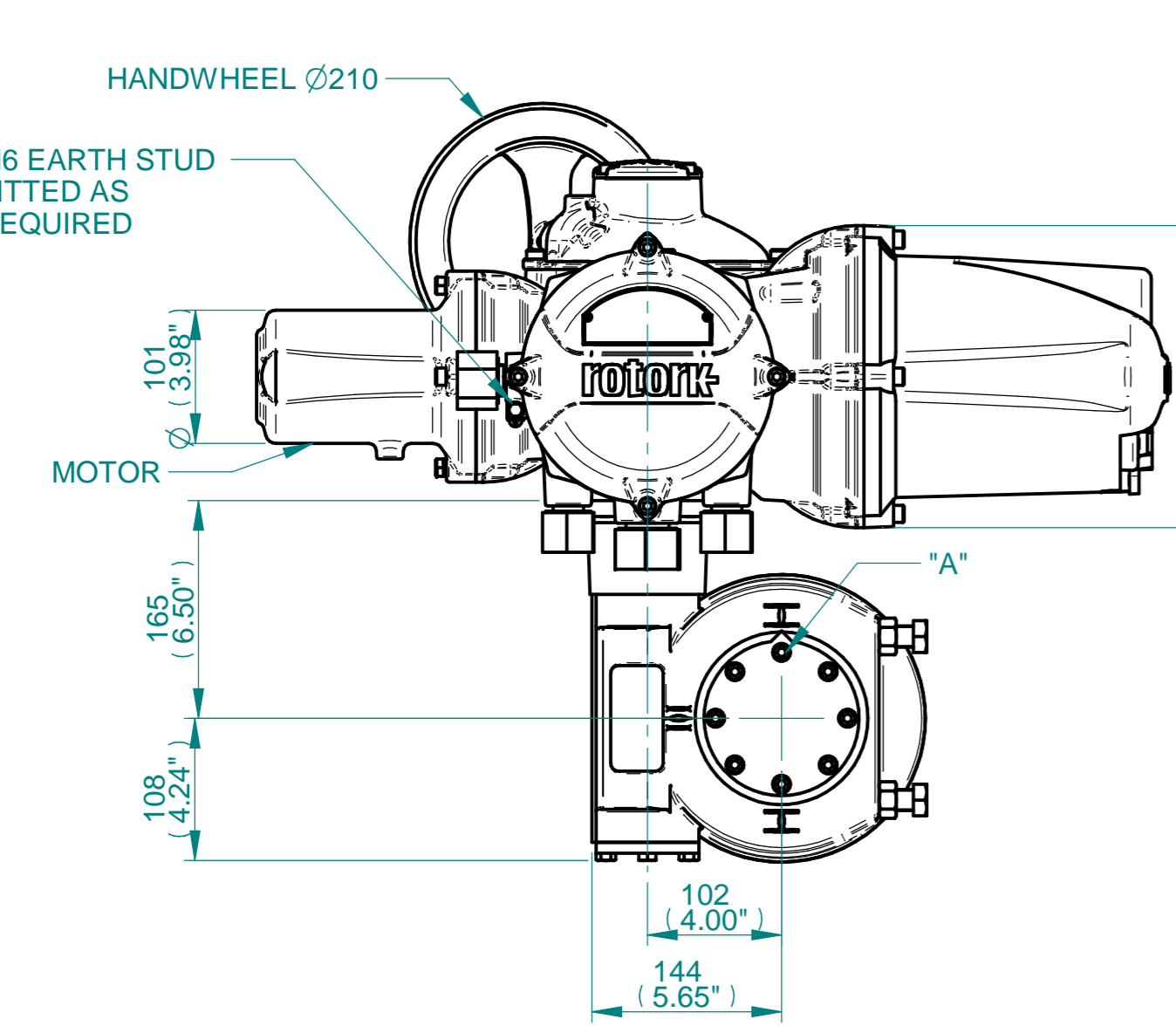

N.B. KEYWAY POS. CAN BE MOVED IN 45° STEPS BY REMOVING 8 SCREWS MARKED "A" AND ROTATING OUTPUT SLEEVE
 SEE GEARBOX OUTPUT FLANGE OPTIONS TABLE
 SEE MAXIMUM BORE & KEY TABLE

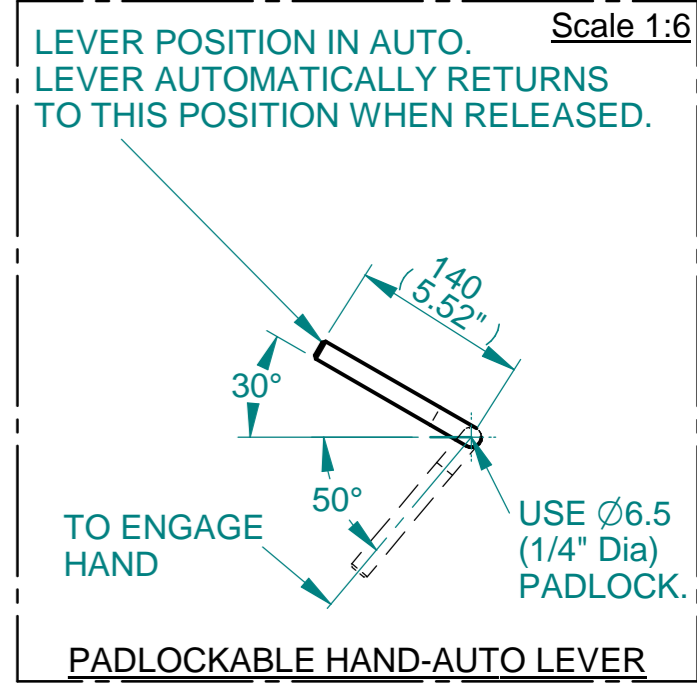

Actuator Size: IQ10/12/18 IWD4		Gearbox output flange options								Maximum Bore & Key		
Title IQ10/12/18, SIDE HANDWHEEL, IWD4, F12/F14/FA12/FA14, Ratios 40:1 & 70:1 Installation Details Drawn WJH Checked NJC Date 16-APR-15 Ref SALES Project Ref QUOTATION	Designation	F12	F14	-	-	FA12	FA14	-	-	Key form	Ø Bore	Key size
	No. Holes	4	4	-	-	4	4	-	-	Rectangle (BS4235)	64	18 X 11
	Hole size	M12	M16	-	-	1/2" UNC	5/8" UNC	-	-	Rectangle (ANSI B17.1)	2-1/2"	5/8 X 7/16"
	PCD	125	140	-	-	4.95"	5.5"	-	-	Square (ANSI B17.1)	2-1/4"	1/2" SQ

3D Models are available in various formats under the same drawing number

Issue	Description
1	First Issue

Scale: 1:5 THIRD ANGLE PROJECTION

Drawing Number	Issue No	Sheet No
I11SHWIWD4STD	1	1 of 1

1 2 3 4 5 6 7 8 9 10 11 12