

H
G
F
E
D
C
B
A

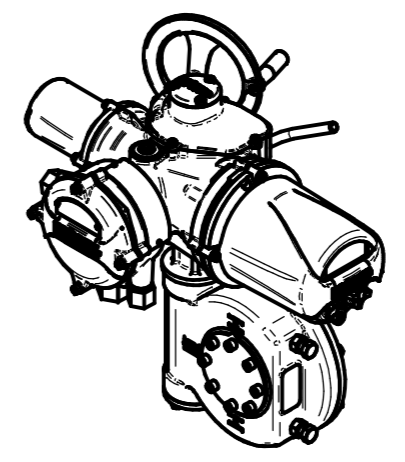
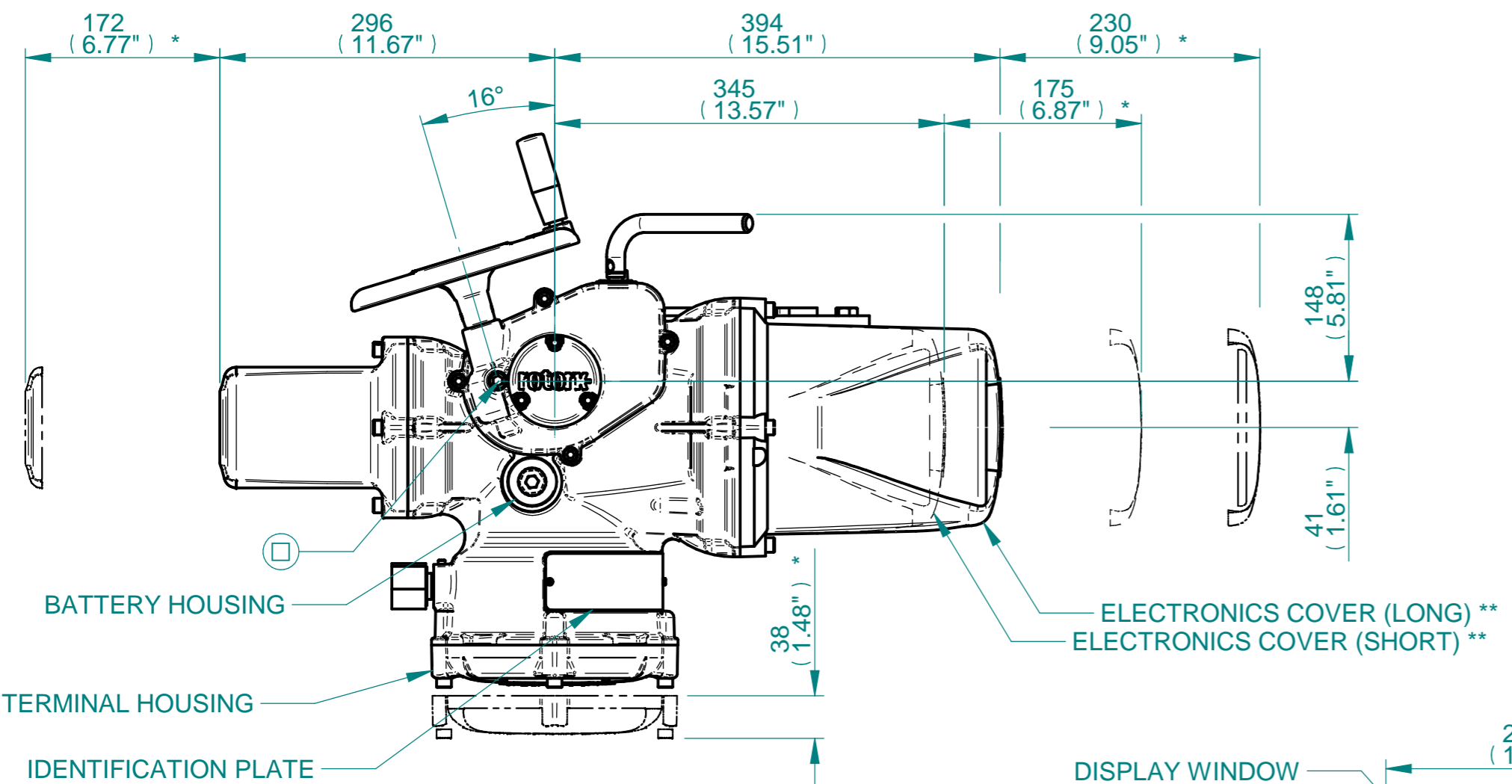

ISOMETRIC VIEW
(SCALE 1:12)

NOTES:
 :DIMENSIONS WITH "*" INDICATE COVER REMOVAL ALLOWANCE
 :ELECTRONICS COVER OPTION "****" WILL VARY DEPENDING ON CONFIGURATION
 :NETT WEIGHT = 76g/168lbs
 : = OIL FILLER/DRAIN PLUG
 :THE INTERFACE PROVIDED FOR MOUNTING THE ACTUATOR OR SECOND STAGE GEARBOX ONTO THE VALVE SHOULD CONFORM TO GOOD ENGINEERING PRACTICES, ENSURING ADEQUATELY TOLERANCED LIMITS FOR PARALLELISM, PERPENDICULARITY AND CONCENTRICITY.
 :ROTORC KANNOT BE HELD LIABLE FOR DAMAGE TO OUR EQUIPMENT CAUSED BY EXCESSIVE LOADING FROM COVER TUBES. (SEE ALSO E156E)

CONDUIT ENTRIES

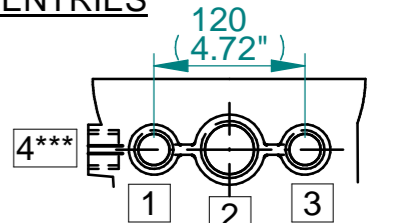

	Hole 1	Hole 2	Hole 3	Hole 4***
Size	As Required	As Required	As Required	As Required
Plugged	As Required	As Required	As Required	As Required
Gland	As Required	As Required	As Required	As Required

***HOLE 4 IS OPTIONAL

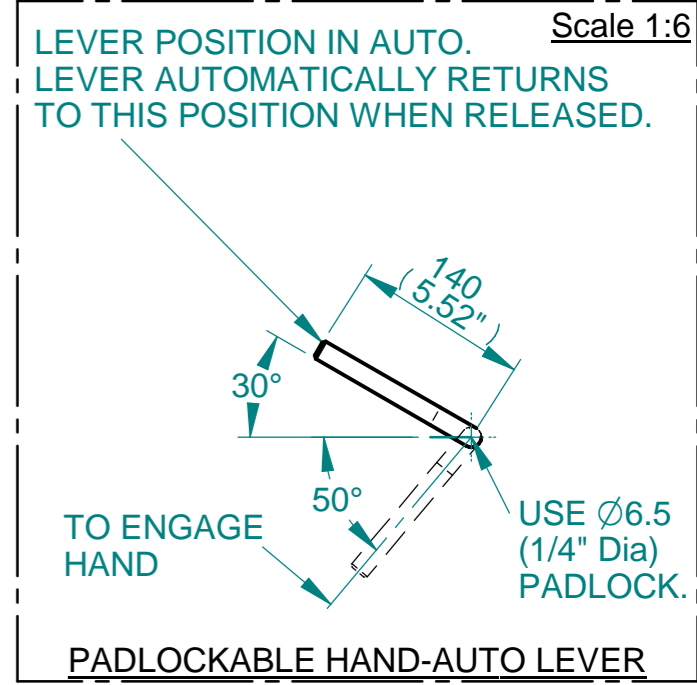
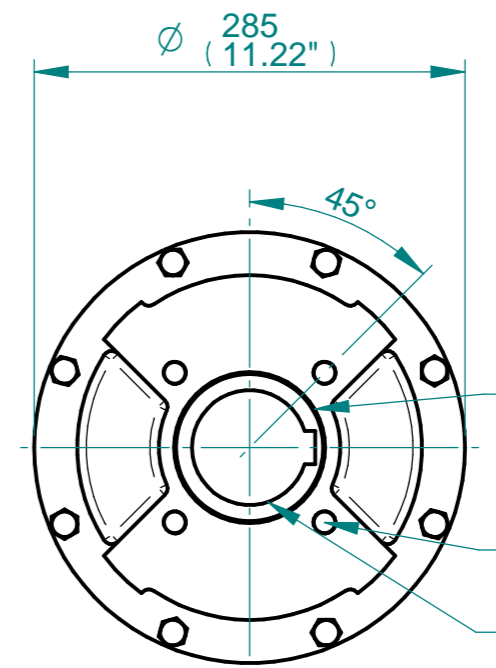
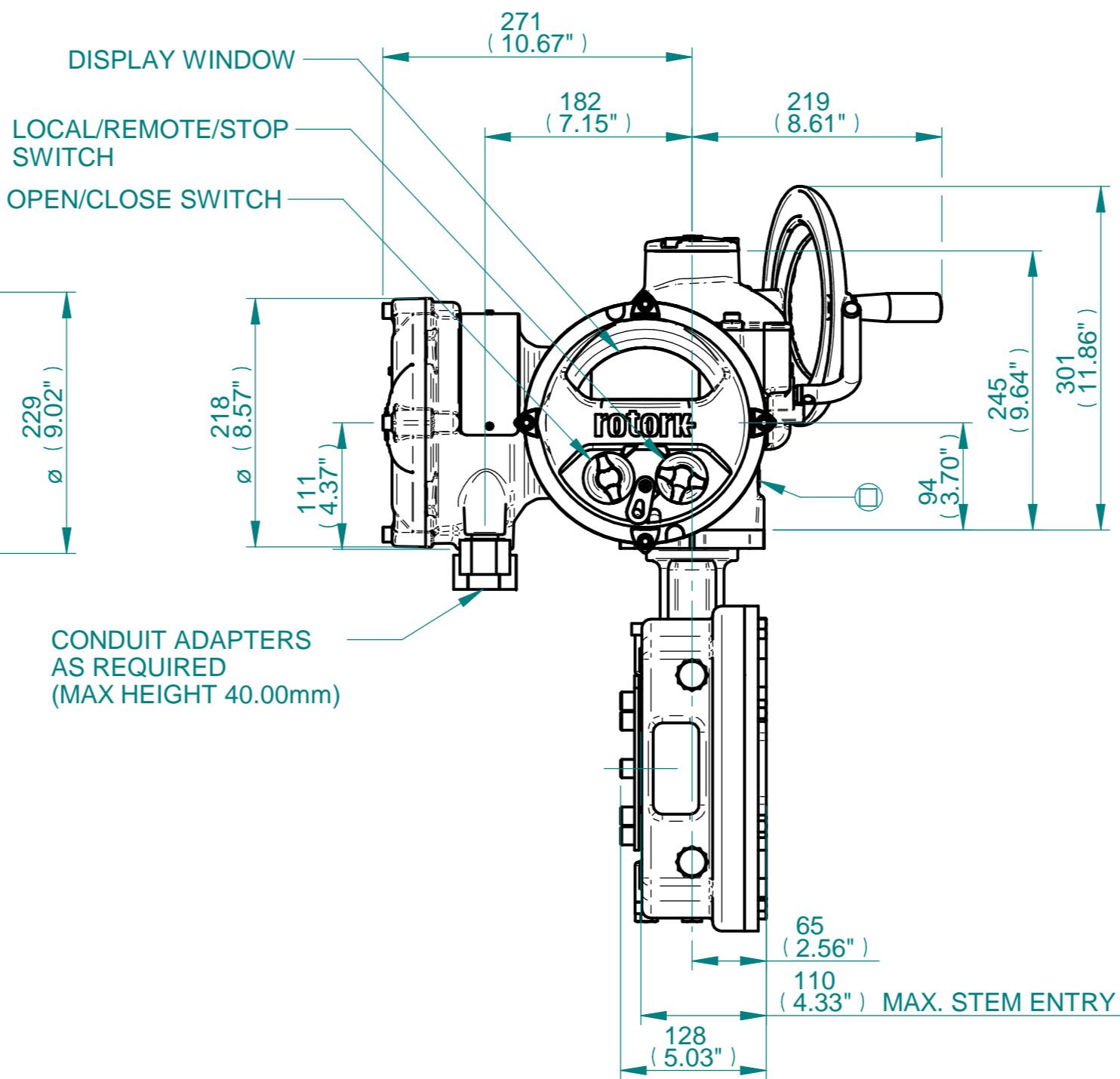
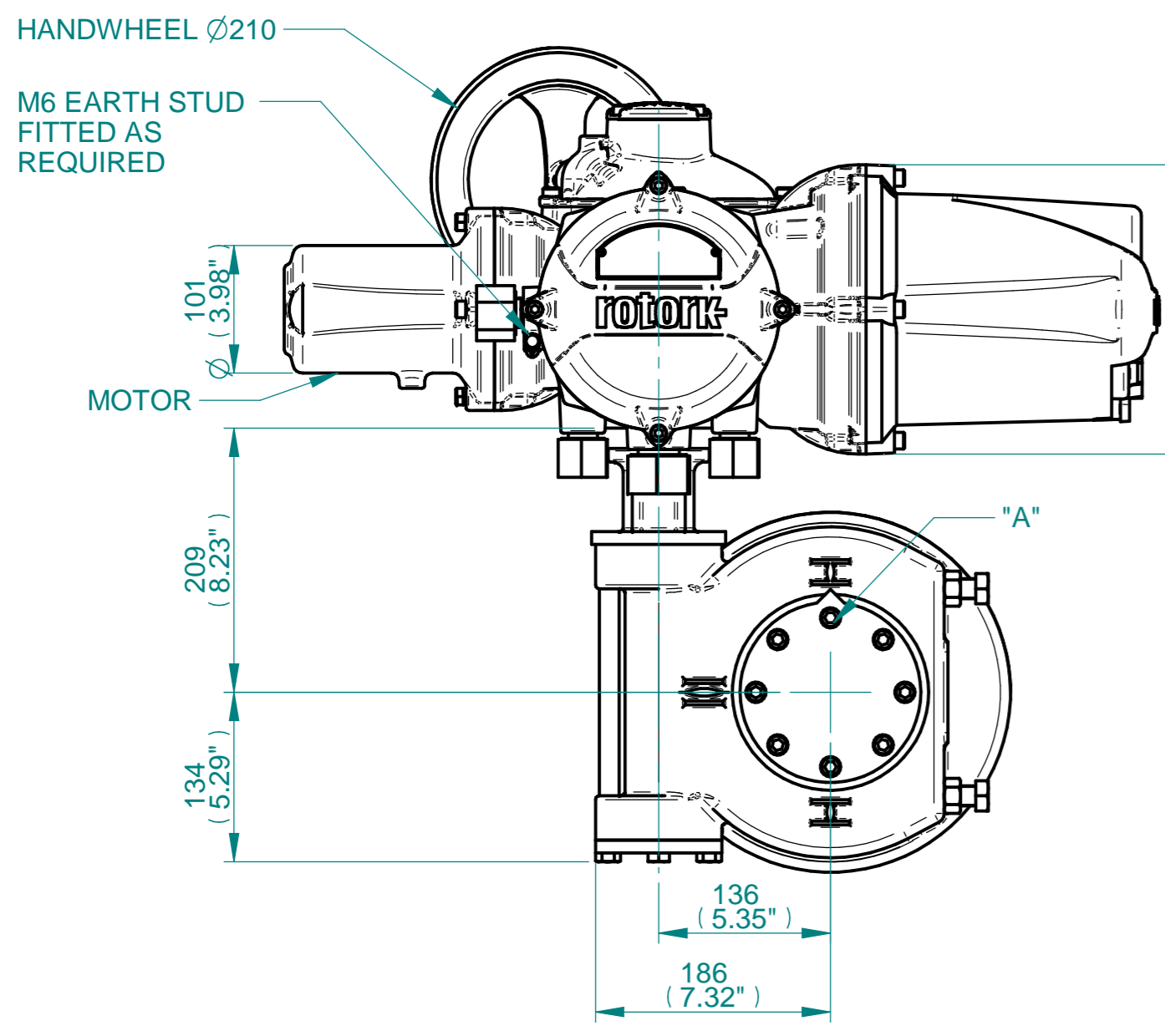

N.B. KEYWAY POS. CAN BE MOVED IN 45° STEPS BY REMOVING 8 SCREWS MARKED "A" AND ROTATING OUTPUT SLEEVE
 SEE GEARBOX OUTPUT FLANGE OPTIONS TABLE
 SEE MAXIMUM BORE & KEY TABLE

3D Models are available in various formats under the same drawing number



Actuator Size: IQ10/12/18 IWD5		Gearbox output flange options								Maximum Bore & Key		
Title IQ10/12/18, SIDE HANDWHEEL, IWD5, F14/F16/FA14/FA16, Ratios 40:1 & 70:1 Installation Details Drawn WJH Checked NJC Date 16-APR-15 Ref SALES Project Ref QUOTATION	Designation	F14	F16	-	-	FA14	FA16	-	-	Key form	Ø Bore	Key size
	No. Holes	4	4	-	-	4	4	-	-	Rectangle (BS4235)	76	22 x 14
	Hole size	M16	M20	-	-	5/8" UNC	3/4" UNC	-	-	Rectangle (ANSI B17.1)	3"	3/4 x 1/2"
	PCD	140	165	-	-	5.5"	6.5"	-	-	Square (ANSI B17.1)	2-3/4"	5/8" SQ

Issue	Description
1	First Issue

Scale: 1:5 THIRD ANGLE PROJECTION

Drawing Number	Issue No	Sheet No
I11SHWIWD5STD	1	1 of 1

1 2 3 4 5 6 7 8 9 10 11 12