

H
G
F
E
D
C
B
A

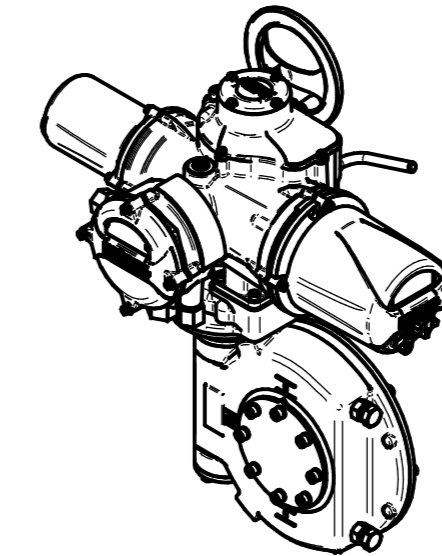
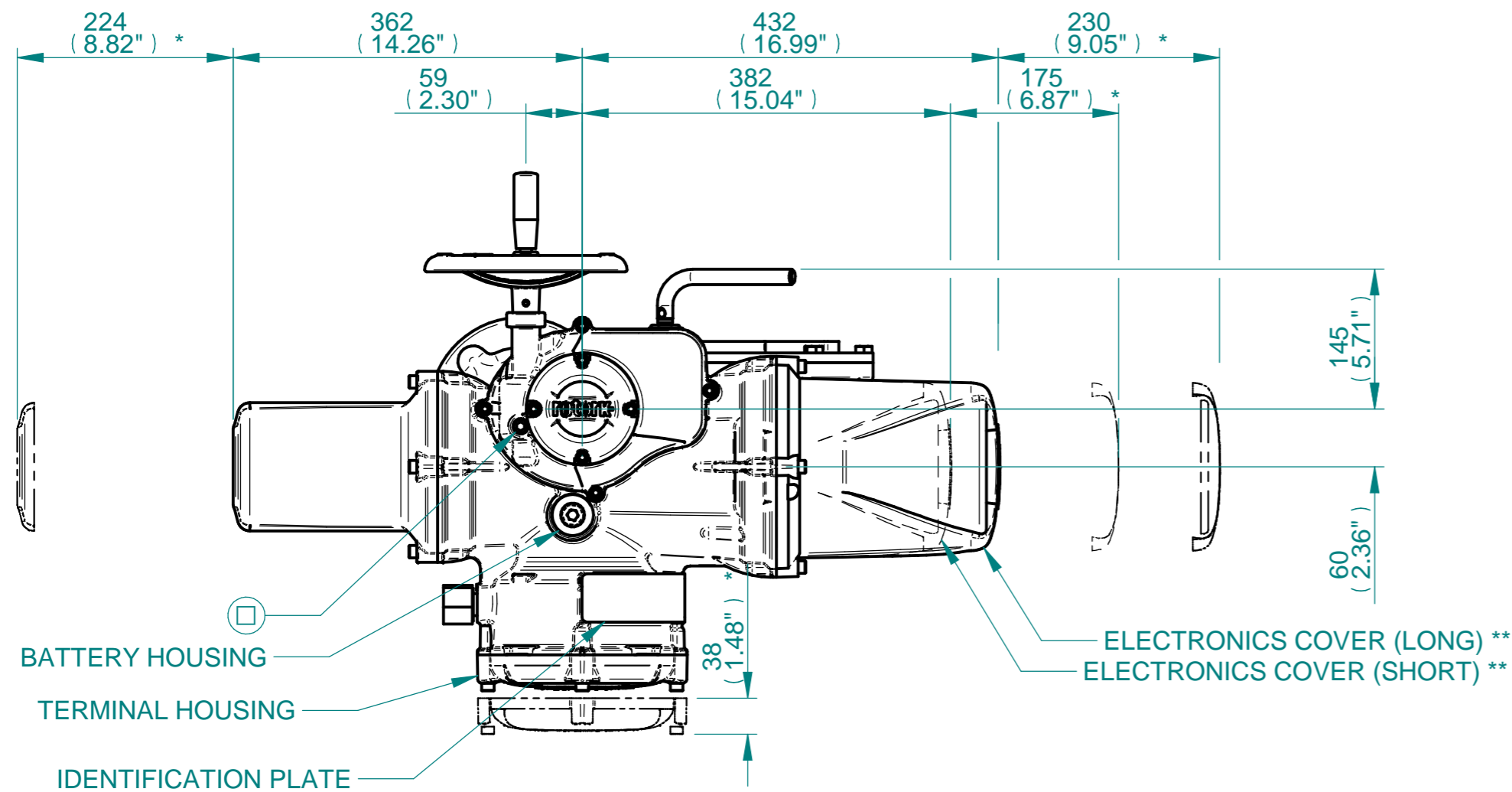

ISOMETRIC VIEW
(SCALE 1:12)

NOTES:
 :DIMENSIONS WITH "*" INDICATE COVER REMOVAL ALLOWANCE
 :ELECTRONICS COVER OPTION "****" WILL VARY DEPENDING ON CONFIGURATION
 :NETT WEIGHT = 133kg/293lbs
 : = OIL FILLER/DRAIN PLUG
 :THE INTERFACE PROVIDED FOR MOUNTING THE ACTUATOR OR SECOND STAGE GEARBOX ONTO THE VALVE SHOULD CONFORM TO GOOD ENGINEERING PRACTICES, ENSURING ADEQUATELY TOLERANCED LIMITS FOR PARALLELISM, PERPENDICULARITY AND CONCENTRICITY.
 :ROTORC CANNOT BE HELD LIABLE FOR DAMAGE TO OUR EQUIPMENT CAUSED BY EXCESSIVE LOADING FROM COVER TUBES. (SEE ALSO E156E)

CONDUIT ENTRIES

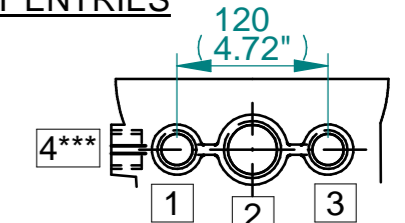

	Hole 1	Hole 2	Hole 3	Hole 4***
Size	As Required	As Required	As Required	As Required
Plugged	As Required	As Required	As Required	As Required
Gland	As Required	As Required	As Required	As Required

***HOLE 4 IS OPTIONAL

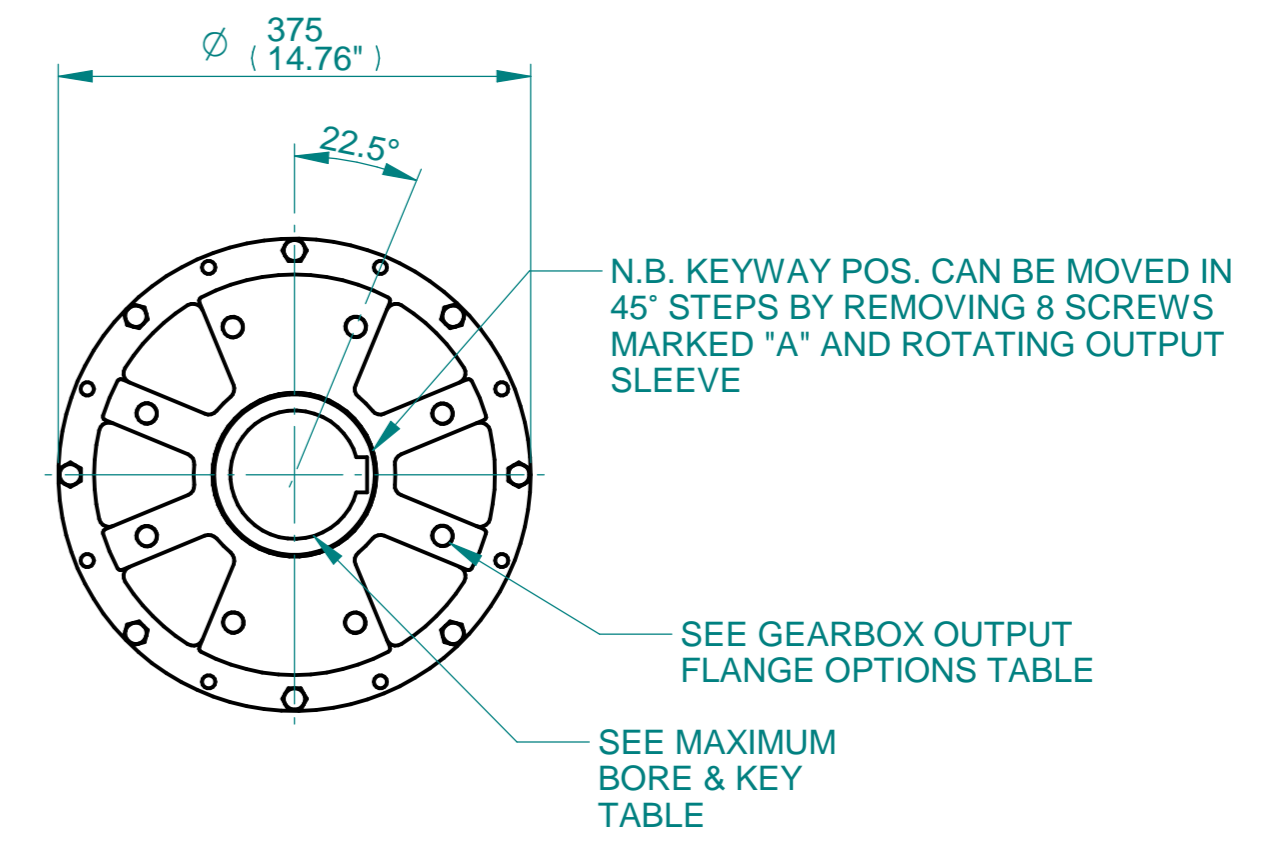
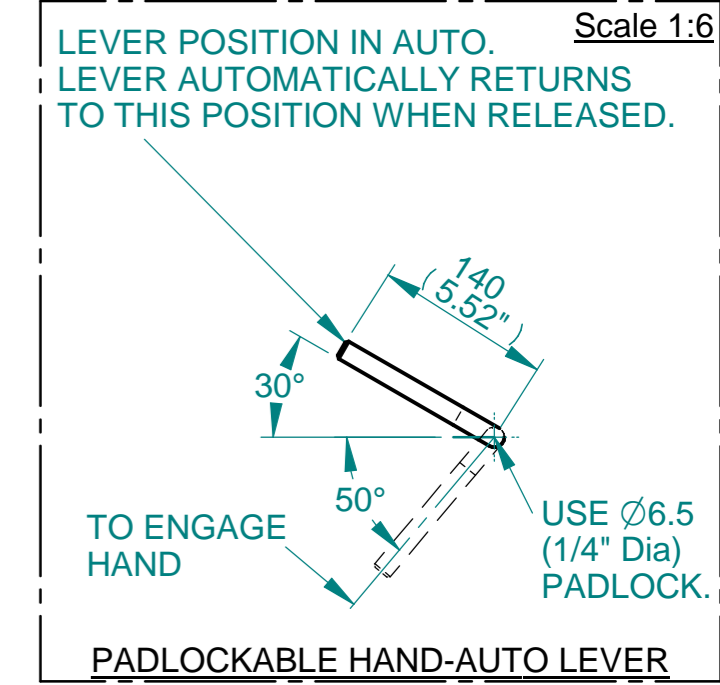
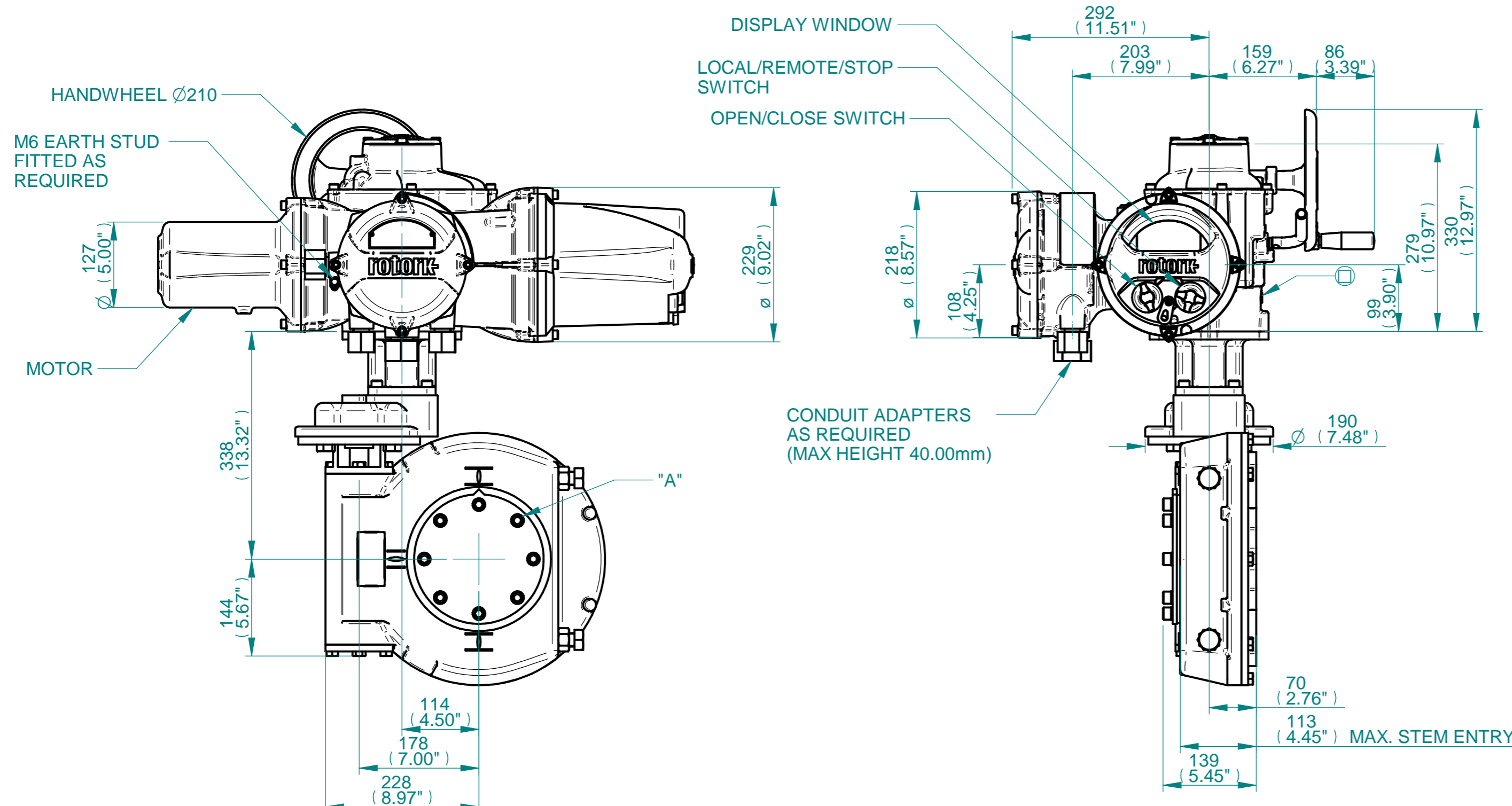

3D Models are available in various formats under the same drawing number

rotork
www.rotork.com
Rotork Controls Limited
Bath, BA1 3JQ, England.
Telephone 01225-733200

Actuator Size: IQ20/25 IWD6RL		Gearbox output flange options								Maximum Bore & Key			
Title	IQ20/25, SIDE HANDWHEEL, IWD6RL, F16/F25/FA16/FA25, Ratios 140:1 - 280:1 Installation Details	Designation	F16	F25	-	-	FA16	FA25	-	-	Key form	Ø Bore	Key size
Drawn	NJC	No. Holes	4	8	-	-	4	8	-	-	Rectangle (BS4235)	102	28 X 16
Checked	PMJ	Hole size	M20	M16	-	-	3/4" UNC	5/8" UNC	-	-	Rectangle (ANSI B17.1)	3-7/8"	1 X 3/4"
Date	13-MAY-15	PCD	165	254	-	-	6.5"	10"	-	-	Square (ANSI B17.1)	3-3/4"	7/8" SQ
Ref	SALES	Project Ref	QUOTATION										

Issue	Description
1	First Issue

Scale: 1:6 THIRD ANGLE PROJECTION

Drawing Number	Issue No	Sheet No
I12SHWIWD6RLSTD	1	1 of 1

1 2 3 4 5 6 7 8 9 10 11 12