

1	2		3		4		5		6			7		8	
INPUT FLANGE DETAILS							MOUNTING HOLES - BOLT CIRCLE (OFF CENTRES)								
INPUT FLANGE	FLANGE O/DIA. + THICKNESS	SHAFT DIA.	RECESS DIA.	RECESS DEPTH	HOLE DETAILS (45° OFF CENTRES)	KEY DETAILS	ISO 5211 / MSS SP-101 MOUNTING OPTION	HOLE DETAILS (22.5° OFF CENTRES)	STANDARD	MIN BORE	SQ KEY MAX BORE	SQ KEY SIZE	RECT. KEY MAX BORE	RECT. KEY SIZE	SQ BORE MAX
ISO F10	Ø125 x 20 (Ø4.92" x 0.787")	Ø20.00-0.05 (Ø0.787"-0.002")	Ø70.05+0.15 (Ø2.758"+0.006")	4 (0.16")	4 x Ø10.5 ON Ø102.0 P.C. (4 x Ø0.41" ON Ø4.02" P.C.)	6x6x55 (0.24"x0.24"x2.17")	ISO F25*	8 x M16 x 24 (0.94") DEEP ON Ø254.0 (Ø10.00") P.C.	BS4235	-	-	-	136	36 x 20	□ 108.8 (4.28")
FA10			FA25*				8 x 5/8" UNC x 24 (0.94") DEEP ON Ø254.0 (Ø10.00") P.C.		ANSI B17.1	-	4.875"	1.1/4" SQ.	5.25"	1.1/4" x 7/8"	
		Ø58.70+0.15 (Ø2.311"+0.006")					DIN 6885	-	-	-	136	36 x 20			

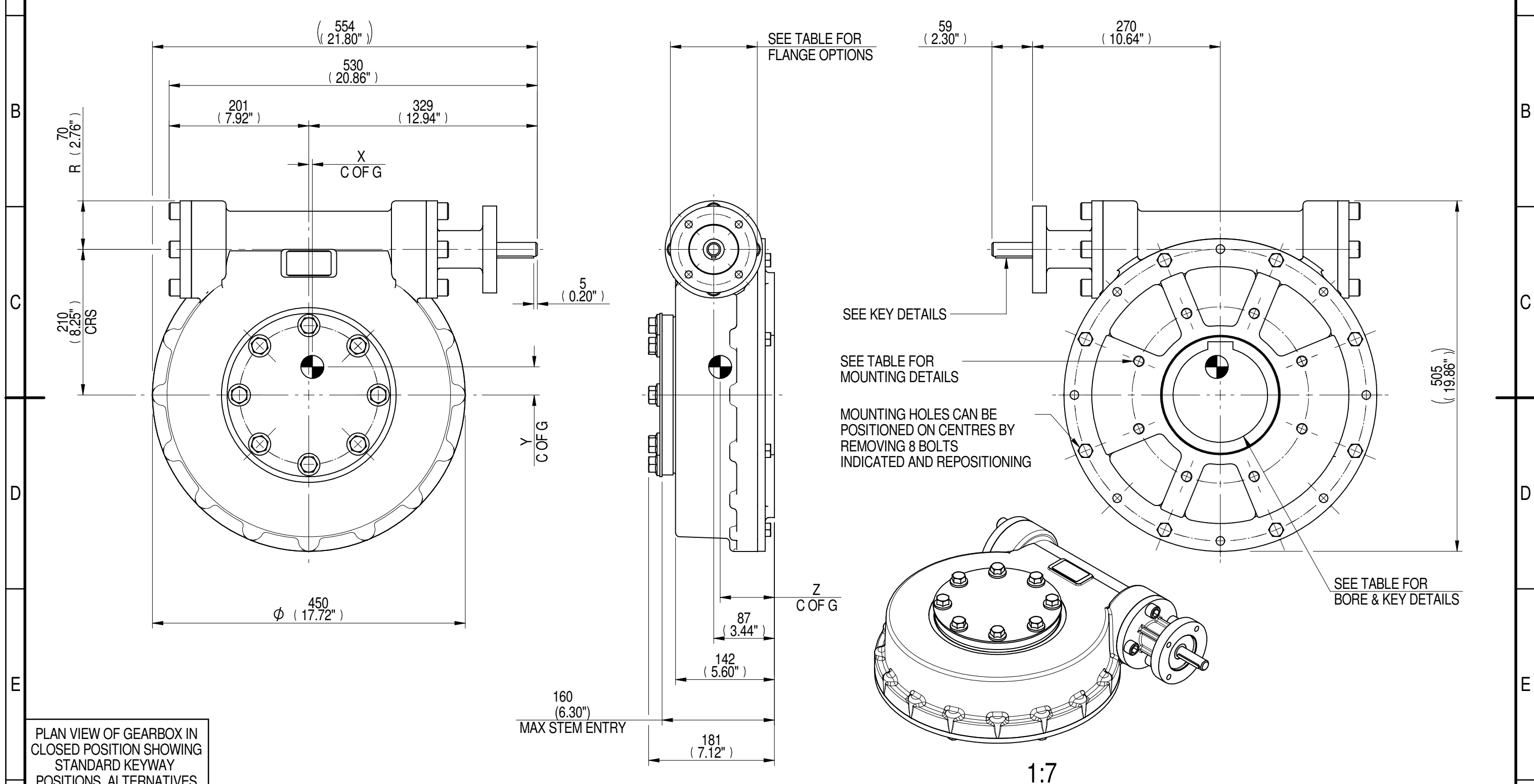

PLAN VIEW OF GEARBOX IN CLOSED POSITION SHOWING STANDARD KEYWAY POSITIONS. ALTERNATIVES AVAILABLE ON REQUEST

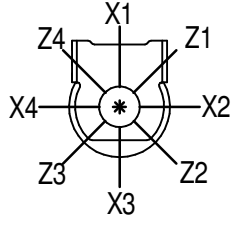

NOTES:  
 1. \* THREAD DEPTH DOES NOT MATCH ISO STANDARD  
 2. CENTRE OF GRAVITY POSITION IS INDICATIVE FOR STANDARD BUILD WHEN IN POSITION SHOWN

60	23	102	10846	434	5	40	78
RATIO	M.A. ± 10%	WEIGHT (Kg)	MAX OUTPUT (Nm)	MAX INPUT (Nm)	X	Y	Z
DESCRIPTION			TORQUE		CENTRE OF GRAVITY		

AS PART OF CONTINUOUS PRODUCT DEVELOPMENT, ALL DETAILS SUBJECT TO CHANGE WITHOUT PRIOR NOTICE. FOR UP TO DATE DETAILS PLEASE VISIT [www.rotork.com](http://www.rotork.com)

**rotork** Gears  
 LEEDS - UK  
[www.rotork.com](http://www.rotork.com)

This drawing is confidential and is the property of Rotork Gears and must not be reproduced either wholly or partly. All rights in respect of patents, designs and copyrights are reserved. ©2015

Document Type **PUBLICITY**  
 Dimensions in mm

Title  
**MTW7 MULTI-TURN GEARBOX, 60:1 F10/FA10 INPUT, F25/FA25 OUTPUT**

Drawing Number  
**PUB-MTW7-F10-F25**

Sheet 1 of 1 Size A3

Iss. 01