

INPUT FLANGE DETAILS							MOUNTING HOLES - BOLT CIRCLE (OFF CENTRES)								
INPUT FLANGE	FLANGE O/DIA. + THICKNESS	SHAFT DIA.	RECESS DIA.	RECESS DEPTH	HOLE DETAILS (45° OFF CENTRES)	KEY DETAILS	ISO 5211 / MSS SP-101 MOUNTING OPTION	HOLE DETAILS (22.5° OFF CENTRES)	STANDARD	MIN BORE	SQ KEY MAX BORE	SQ KEY SIZE	RECT. KEY MAX BORE	RECT. KEY SIZE	SQ BORE MAX
-	-	Ø50.00-0.05 (Ø1.969"-0.002")	-	-	-	14x9x55 (0.55"x0.35"x2.17")	ISO F35*	8 x M30 x 30 (1.18") DEEP ON Ø356.0 (Ø14.02") P.C.	BS4235	-	-	-	157	40 x 22	□ 122.9 (4.84")
-	-	-	-	-	-	-	FA35*	8 x 1" UNC x 30 (1.18") DEEP ON Ø355.6 (Ø14.00") P.C.	BS46	-	5.625"	1.1/2" SQ.	6.00"	1.1/2" x 1"	
-	-	-	-	-	-	-	-	ANSI B17.1 DIN 6885	-	-	5.625"	1.1/2" SQ.	6.00"	1.1/2" x 1"	

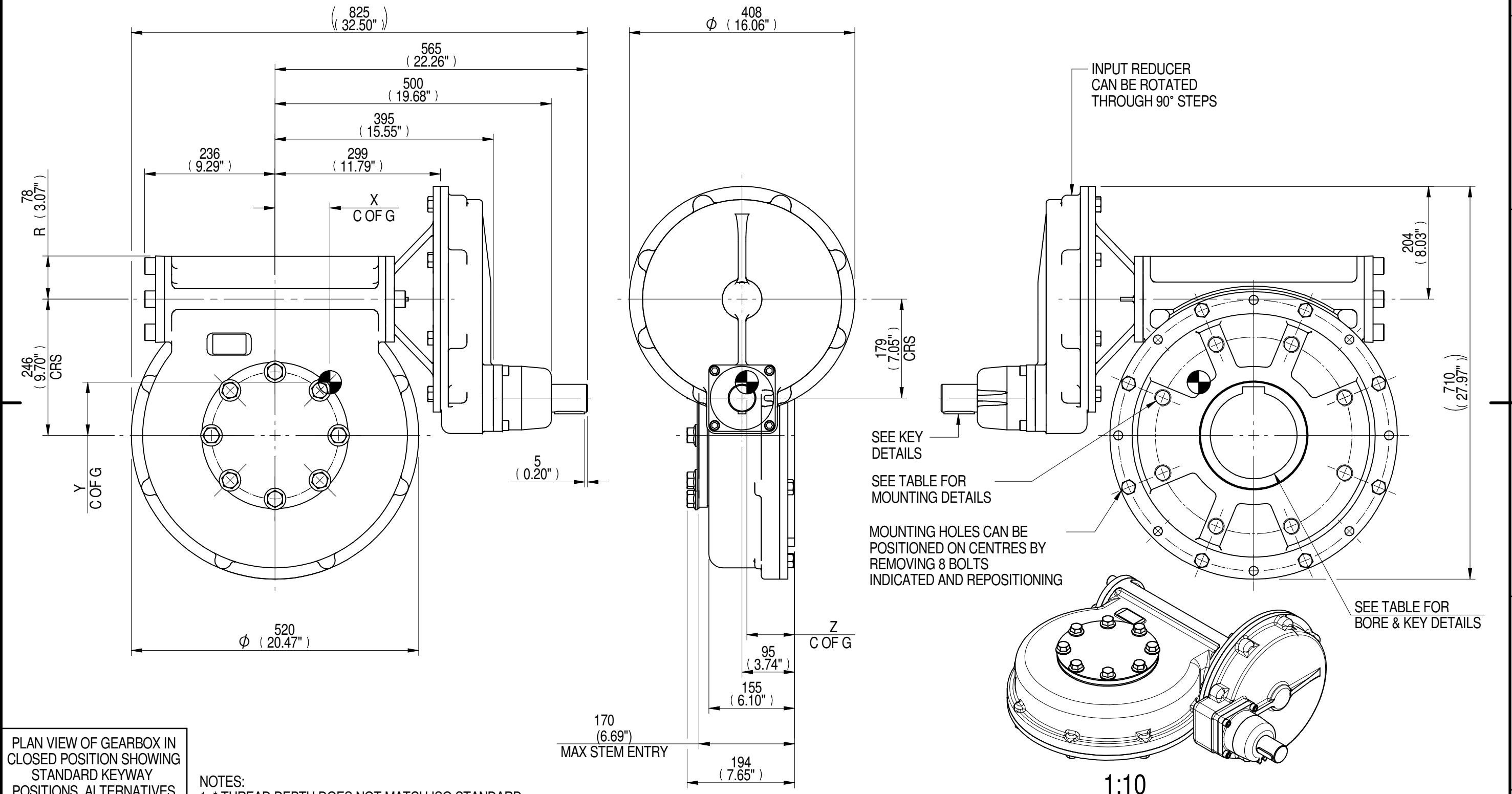

PLAN VIEW OF GEARBOX IN CLOSED POSITION SHOWING STANDARD KEYWAY POSITIONS. ALTERNATIVES AVAILABLE ON REQUEST

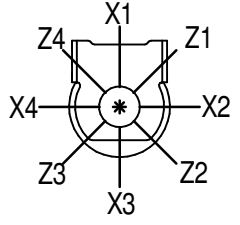

NOTES:
 1. * THREAD DEPTH DOES NOT MATCH ISO STANDARD
 2. CENTRE OF GRAVITY POSITION IS INDICATIVE FOR STANDARD BUILD WHEN IN POSITION SHOWN

720	285	215	21693	76	102	98	86
540	214	213	21693	101	100	97	86
480	189	213	21693	115	99	96	86
RATIO	M.A. ± 10%	WEIGHT (Kg)	MAX OUTPUT (Nm)	MAX INPUT (Nm)	X	Y	Z
DESCRIPTION			TORQUE		CENTRE OF GRAVITY		

AS PART OF CONTINUOUS PRODUCT DEVELOPMENT, ALL DETAILS SUBJECT TO CHANGE WITHOUT PRIOR NOTICE. FOR UP TO DATE DETAILS PLEASE VISIT www.rotork.com

rotork Gears
 LEEDS - UK
www.rotork.com

This drawing is confidential and is the property of Rotork Gears and must not be reproduced either wholly or partly. All rights in respect of patents, designs and copyrights are reserved. ©2015

Document Type **PUBLICITY**
 Dimensions in mm

Title
MTW8 MULTI-TURN GEARBOX, 480/540/720:1 MANUAL INPUT, F35/FA35 OUTPUT

Drawing Number
PUB-MTW8IRL-MAN-F35

Sheet 1 of 1 Size A3

Iss. 01