

1	2		3		4		5		6			7		8	
INPUT FLANGE DETAILS							MOUNTING HOLES - BOLT CIRCLE (OFF CENTRES)								
INPUT FLANGE	FLANGE O/DIA. + THICKNESS	SHAFT DIA.	RECESS DIA.	RECESS DEPTH	HOLE DETAILS (45° OFF CENTRES)	KEY DETAILS	ISO 5211 / MSS SP-101 MOUNTING OPTION	HOLE DETAILS (22.5° OFF CENTRES)	STANDARD	MIN BORE	SQ KEY MAX BORE	SQ KEY SIZE	RECT. KEY MAX BORE	RECT. KEY SIZE	SQ BORE MAX
ISO F10	Ø125 x 15 (Ø4.92" x 0.59")	Ø20.00-0.05 (Ø0.787"-0.002")	Ø70.05+0.15 (Ø2.758"+0.006")	4 (0.16")	4 x Ø10.5 ON Ø102.0 P.C. (4 x Ø0.41" ON Ø4.02" P.C.)	6x6x40 (0.24"x0.24"x1.57")	ISO F30*	8 x M20 x 30 (1.18") DEEP ON Ø298.0 (Ø11.73") P.C.	BS4235	-	-	-	178	45 x 25	□ 132.1 (5.20")
FA10			Ø58.70+0.15 (Ø2.311"+0.006")						8 x 3/4" UNC x 30 (1.18") DEEP ON Ø298.5 (Ø11.75") P.C.	ANSI B17.1	-	6.50"	1.1/2" SQ.	6.50"	
									DIN 6885	-	-	-	178	45 x 25	

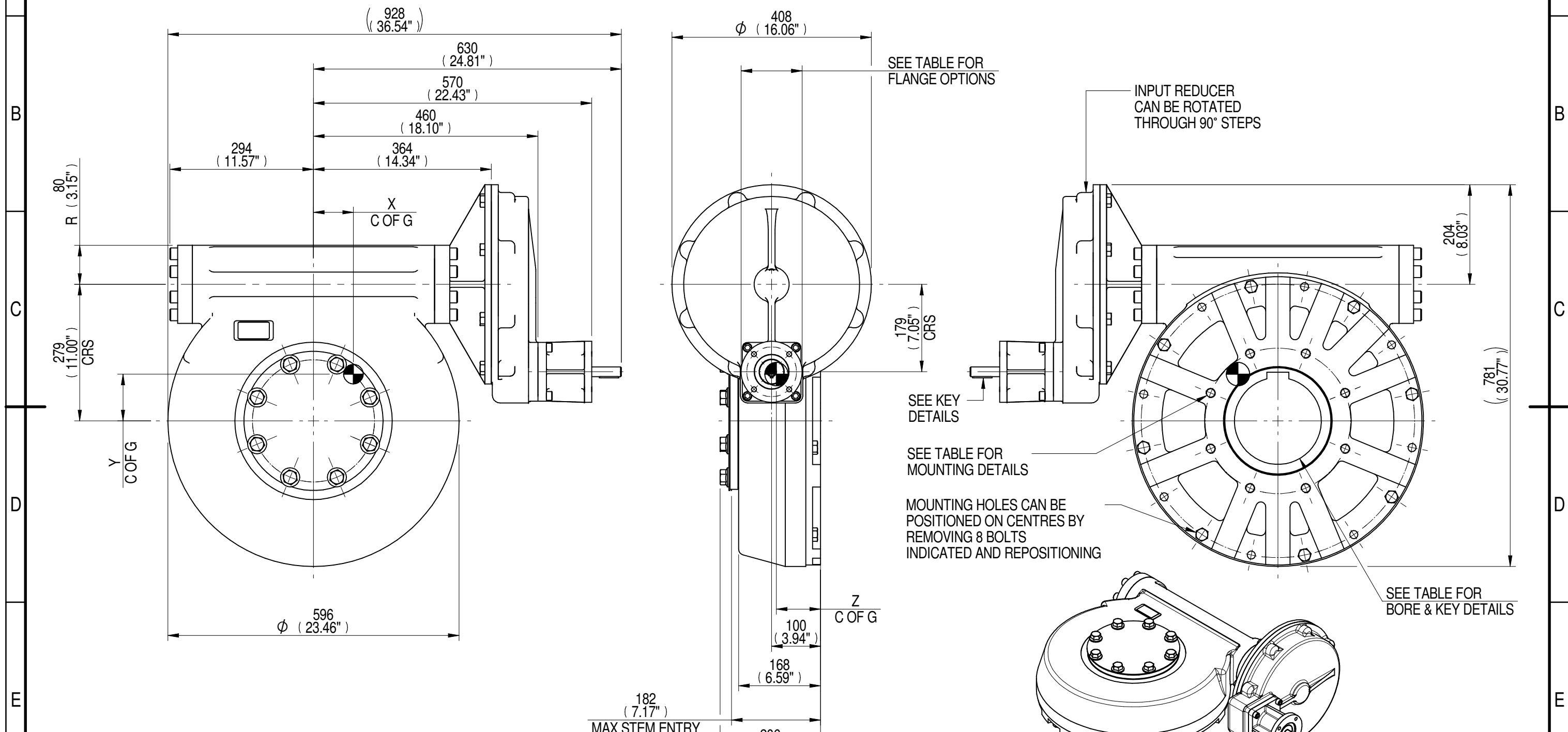

PLAN VIEW OF GEARBOX IN CLOSED POSITION SHOWING STANDARD KEYWAY POSITIONS. ALTERNATIVES AVAILABLE ON REQUEST

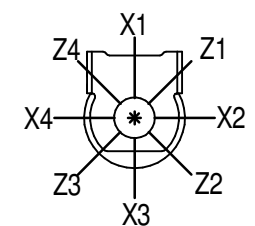

- NOTES:
 1. * THREAD DEPTH DOES NOT MATCH ISO STANDARD
 2. CENTRE OF GRAVITY POSITION IS INDICATIVE FOR STANDARD BUILD WHEN IN POSITION SHOWN

720	285	300	39318	138	85	99	90
540	214	298	39318	184	83	97	90
360	142	298	39318	277	83	97	90
240	95	298	39318	414	83	97	90
180	71	297	39318	554	82	96	90
RATIO	M.A. ±10%	WEIGHT (Kg)	MAX OUTPUT (Nm)	MAX INPUT (Nm)	X	Y	Z
DESCRIPTION			TORQUE		CENTRE OF GRAVITY		

AS PART OF CONTINUOUS PRODUCT DEVELOPMENT, ALL DETAILS SUBJECT TO CHANGE WITHOUT PRIOR NOTICE. FOR UP TO DATE DETAILS PLEASE VISIT www.rotork.com

	Document Type PUBLICITY	Title MTW9 MULTI-TURN GEARBOX, 180/240/360/540/720:1, F10/FA10 INPUT, F30/FA30 OUTPUT Drawing Number PUB-MTW9IR2-F10-F30	Iss. 01
	Dimensions in mm		
LEEDS - UK www.rotork.com	This drawing is confidential and is the property of Rotork Gears and must not be reproduced either wholly or partly. All rights in respect of patents, designs and copyrights are reserved. ©2015		