

| 1                    | 2                         |                              | 3           |              | 4                          |                            | 5  |  | 6          |          | 7               |             | 8                  |                |                |
|----------------------|---------------------------|------------------------------|-------------|--------------|----------------------------|----------------------------|--|--|------------|----------|-----------------|-------------|--------------------|----------------|----------------|
| INPUT FLANGE DETAILS |                           |                              |             |              |                            |                            | MOUNTING HOLES - BOLT CIRCLE (OFF CENTRES) |  |            |          |                 |             |                    |                |                |
| INPUT FLANGE         | FLANGE O/DIA. + THICKNESS | SHAFT DIA.                   | RECESS DIA. | RECESS DEPTH | HOLE DETAILS (OFF CENTRES) | KEY DETAILS                | ISO 5211 / MSS SP-101 MOUNTING OPTION      | HOLE DETAILS (45° OFF CENTRES)                         | STANDARD   | MIN BORE | SQ KEY MAX BORE | SQ KEY SIZE | RECT. KEY MAX BORE | RECT. KEY SIZE | SQ BORE MAX    |
| -                    | -                         | Ø20.00-0.05 (Ø0.787"-0.002") | -           | -            | -                          | 6x6x40 (0.24"x0.24"x1.57") | ISO F16*                                   | 4 x M20 x 20 (0.79") DEEP ON Ø165.0 (Ø6.50") P.C.      | BS4235     | -        | -               | -           | 102                | 28 x 16        | □ 83.3 (3.28") |
| -                    | -                         | -                            | -           | -            | -                          | -                          | FA16*                                      | 4 x 3/4" UNC x 19 (0.75") DEEP ON Ø165.0 (Ø6.50") P.C. | BS46       | -        | 3.625"          | 1" SQ.      | 3.75"              | 1" x 3/4"      |                |
| -                    | -                         | -                            | -           | -            | -                          | -                          | -  | -  | ANSI B17.1 | -        | 3.75"           | 7/8" SQ.    | 3.875"             | 1" x 3/4"      |                |
| -                    | -                         | -                            | -           | -            | -                          | -                          | -  | -  | DIN 6885   | -        | -               | -           | 102                | 28 x 16        | -              |

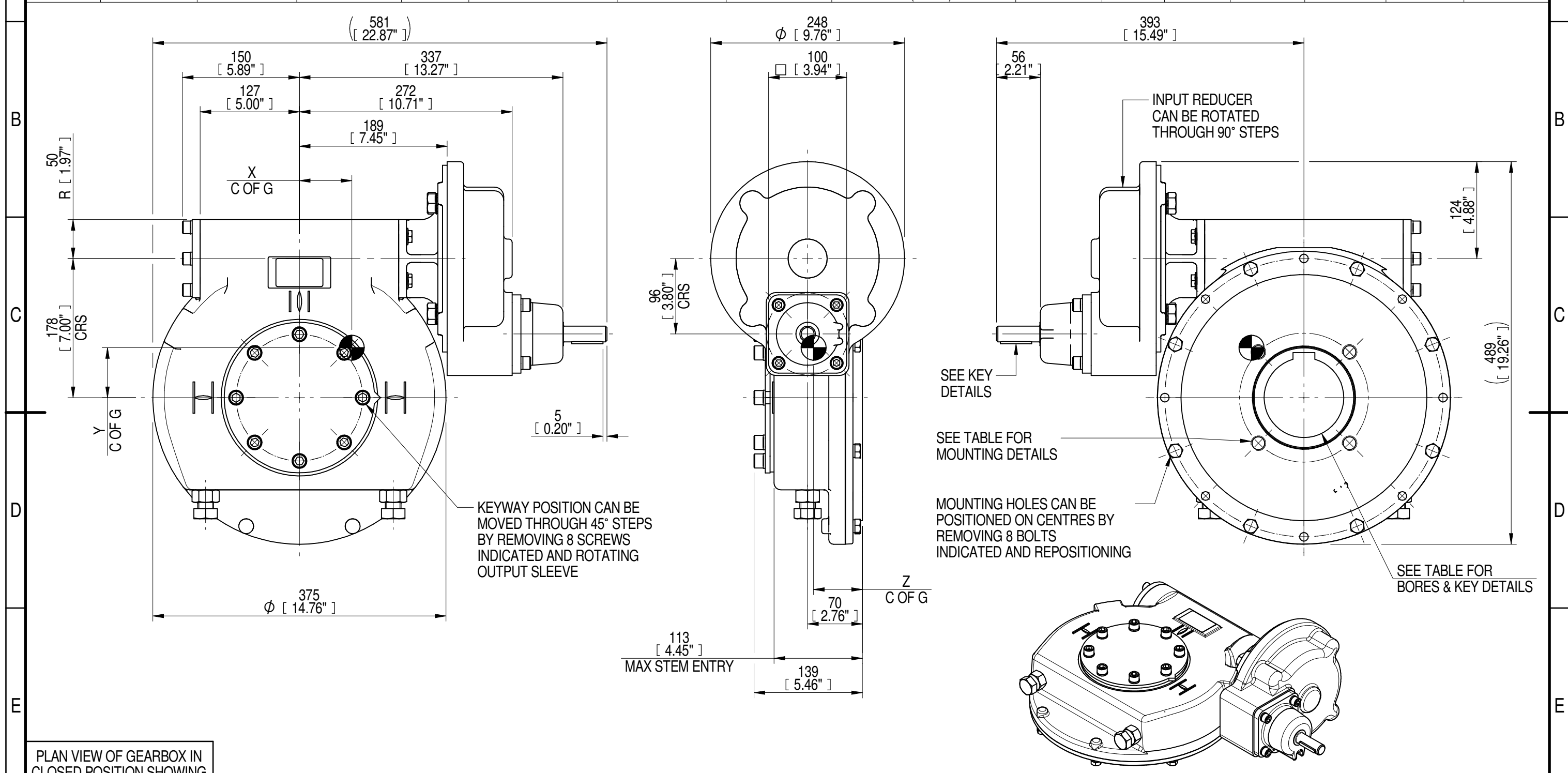

PLAN VIEW OF GEARBOX IN CLOSED POSITION SHOWING STANDARD KEYWAY POSITIONS. ALTERNATIVES AVAILABLE ON REQUEST



NOTES:  
 1. \* THREAD DEPTH DOES NOT MATCH ISO STANDARD  
 2. CENTRE OF GRAVITY POSITION IS INDICATIVE FOR STANDARD BUILD WHEN IN POSITION SHOWN

| 420         | 40             | 132        | 82          | 15300           | 116            | 68                | 64 | 62 |
|-------------|----------------|------------|-------------|-----------------|----------------|-------------------|----|----|
| 350         | 35             | 110        | 82          | 15300           | 139            | 67                | 64 | 62 |
| RATIO       | TURNS TO CLOSE | M.A. ± 10% | WEIGHT (Kg) | MAX OUTPUT (Nm) | MAX INPUT (Nm) | X                 | Y  | Z  |
| DESCRIPTION |                |            |             | TORQUE          |                | CENTRE OF GRAVITY |    |    |

AS PART OF CONTINUOUS PRODUCT DEVELOPMENT, ALL DETAILS SUBJECT TO CHANGE WITHOUT PRIOR NOTICE. FOR UP TO DATE DETAILS PLEASE VISIT [www.rotork.com](http://www.rotork.com)

**rotork** Gears  
 LEEDS - UK  
[www.rotork.com](http://www.rotork.com)

Document Type **PUBLICITY**  
 Dimensions in mm

Title  
**IW/MOW62 QUARTER TURN GEARBOX, 350/420:1  
 MANUAL INPUT : F16/ FA16 OUTPUT**

Drawing Number  
**PUB-IW62FBIRL-MAN-F16**

Sheet 1 of 1 Size A3