

INPUT FLANGE DETAILS							MOUNTING HOLES - BOLT CIRCLE (OFF CENTRES)								
INPUT FLANGE	FLANGE O/DIA. + THICKNESS	SHAFT DIA.	RECESS DIA.	RECESS DEPTH	HOLE DETAILS (OFF CENTRES)	KEY DETAILS	ISO 5211 / MSS SP-101 MOUNTING OPTION	HOLE DETAILS (22.5° OFF CENTRES)	STANDARD	MIN BORE	SQ KEY MAX BORE	SQ KEY SIZE	RECT. KEY MAX BORE	RECT. KEY SIZE	SQ BORE MAX
-	-	Ø30.00-0.03 (Ø1.181"-0.001")	-	-	-	8x7x55 (0.31"x0.28"x2.17")	ISO F30*	8 x M20 x 24 (0.94") DEEP ON Ø298.00 (Ø11.73") P.C.	BS4235	-	-	-	136	36 x 20	□ 108.8 (4.28")
-	-	-	-	-	-	-	FA30*	8 x 3/4" UNC x 24 (0.94") DEEP ON Ø298.45 (Ø11.75") P.C.	ANSI B17.1	-	4.875"	1.1/4" SQ.	5.125"	1.1/2" x 1"	
-	-	-	-	-	-	-	-	-	DIN 6885	-	-	-	136	36 x 20	

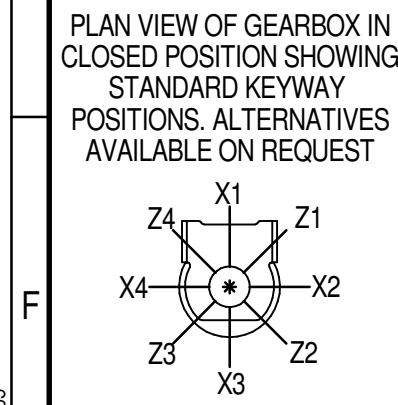
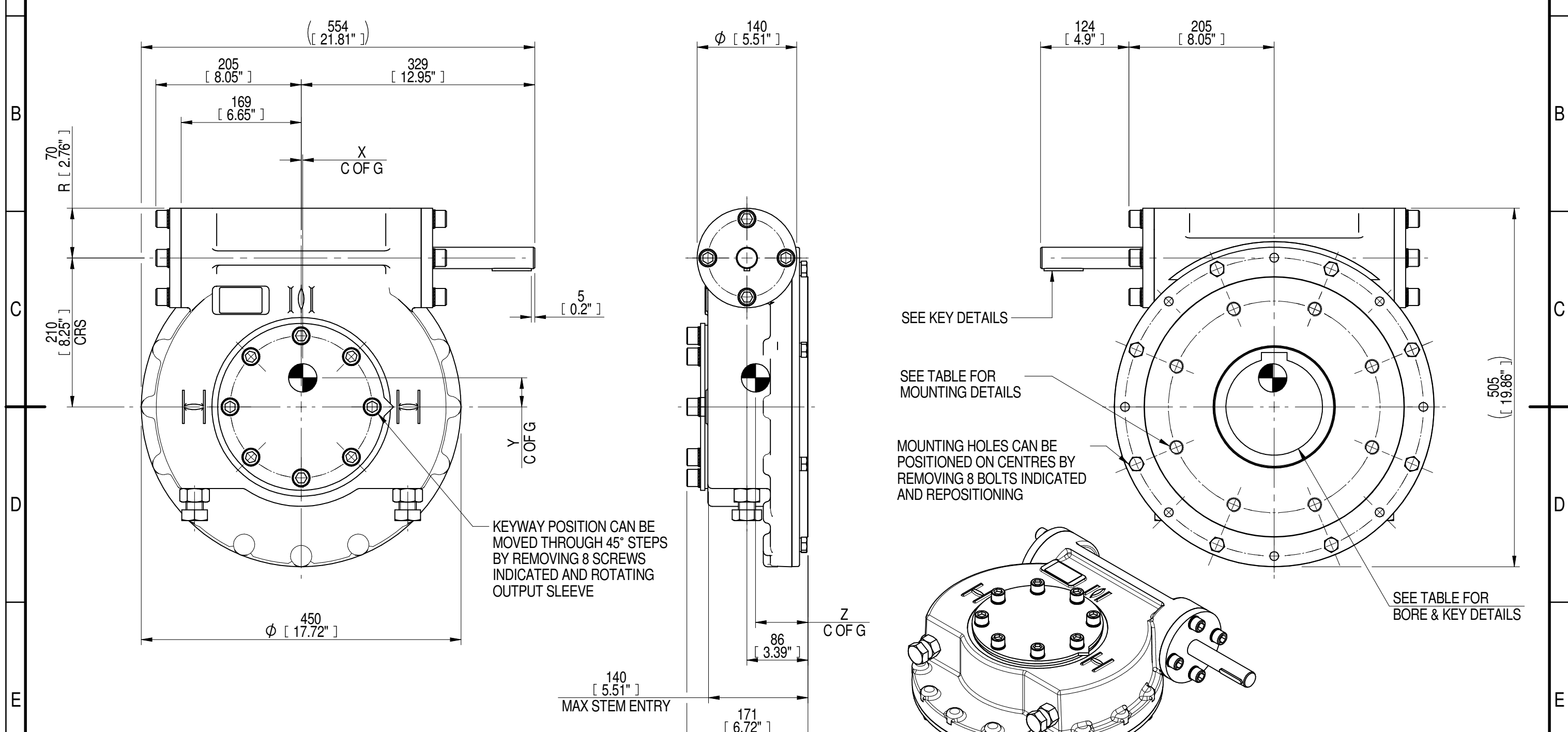

NOTES:
 1. * THREAD DEPTH DOES NOT MATCH ISO STANDARD
 2. CENTRE OF GRAVITY POSITION IS INDICATIVE FOR STANDARD BUILD WHEN IN POSITION SHOWN

RATIO	TURNS TO CLOSE	M.A. ± 10%	WEIGHT (Kg)	MAX OUTPUT (Nm)	MAX INPUT (Nm)	X	Y	Z
60	15	25	98	26000	1040	6	44	74
DESCRIPTION			TORQUE			CENTRE OF GRAVITY		

AS PART OF CONTINUOUS PRODUCT DEVELOPMENT, ALL DETAILS SUBJECT TO CHANGE WITHOUT PRIOR NOTICE. FOR UP TO DATE DETAILS PLEASE VISIT www.rotork.com

rotork Gears
 LEEDS - UK
www.rotork.com

This drawing is confidential and is the property of Rotork Gears and must not be reproduced either wholly or partly. All rights in respect of patents, designs and copyrights are reserved. ©2016

Document Type **PUBLICITY**
 Dimensions in mm

Title
IW/MOW72 QUARTER TURN GEARBOX, 60:1 MANUAL INPUT : F30/FA30 OUTPUT

Drawing Number
PUB-IW72FB-MAN-F30

Sheet 1 of 1 Size A3