

1	2		3		4		5		6		7		8		
INPUT FLANGE DETAILS							MOUNTING HOLES - BOLT CIRCLE (OFF CENTRES)								
INPUT FLANGE	FLANGE O/DIA. + THICKNESS	SHAFT DIA.	RECESS DIA.	RECESS DEPTH	HOLE DETAILS (OFF CENTRES)	KEY DETAILS	ISO 5211 / MSS SP-101 MOUNTING OPTION	HOLE DETAILS (22.5° OFF CENTRES)	STANDARD	MIN BORE	SQ KEY MAX BORE	SQ KEY SIZE	RECT. KEY MAX BORE	RECT. KEY SIZE	SQ BORE MAX
-	-	Ø50.00-0.05 (Ø1.969"-0.002")	-	-	-	14x9x55 (0.55"x0.35"x2.17")	ISO F30*	8 x M20 x 24 (0.94") DEEP ON Ø298.00 (Ø11.73") P.C.	BS4235	-	-	-	136	36 x 20	□ 108.8 (4.28")
-	-	-	-	-	-	-	FA30*	8 x 3/4" UNC x 24 (0.94") DEEP ON Ø298.45 (Ø11.75") P.C.	ANSI B17.1	-	4.875"	1.1/4" SQ.	5.125"	1.1/2" x 1"	
-	-	-	-	-	-	-	-	-	DIN 6885	-	-	-	136	36 x 20	

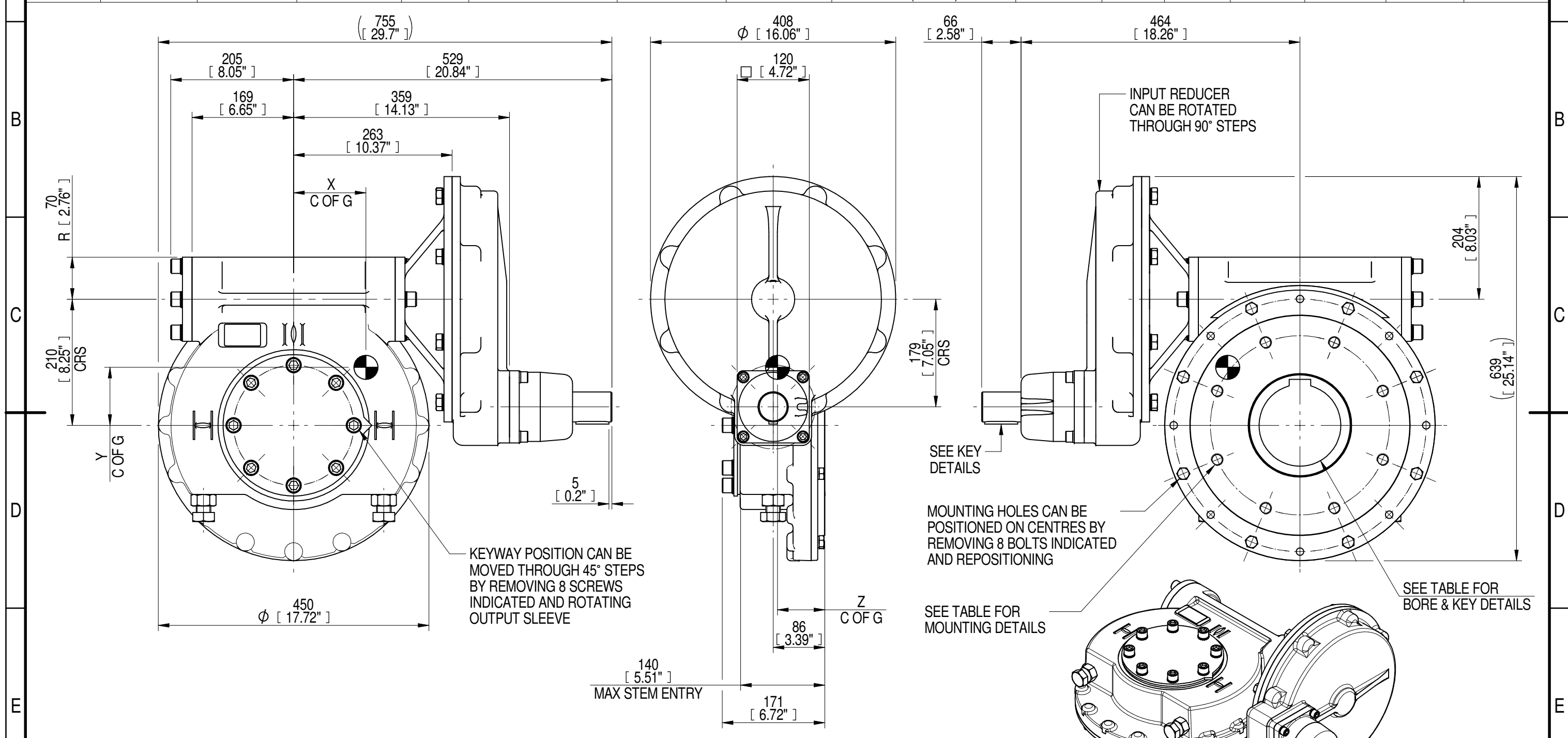

PLAN VIEW OF GEARBOX IN CLOSED POSITION SHOWING STANDARD KEYWAY POSITIONS. ALTERNATIVES AVAILABLE ON REQUEST



NOTES:
 1. * THREAD DEPTH DOES NOT MATCH ISO STANDARD
 2. CENTRE OF GRAVITY POSITION IS INDICATIVE FOR STANDARD BUILD WHEN IN POSITION SHOWN

720	180	285	162	26000	91	122	98	79
540	135	214	161	26000	121	121	97	79
480	120	189	160	26000	138	120	96	79
RATIO	TURNS TO CLOSE	M.A. ± 10%	WEIGHT (Kg)	MAX OUTPUT (Nm)	MAX INPUT (Nm)	X	Y	Z
DESCRIPTION				TORQUE		CENTRE OF GRAVITY		

AS PART OF CONTINUOUS PRODUCT DEVELOPMENT, ALL DETAILS SUBJECT TO CHANGE WITHOUT PRIOR NOTICE. FOR UP TO DATE DETAILS PLEASE VISIT www.rotork.com

	This drawing is confidential and is the property of Rotork Gears and must not be reproduced either wholly or partly. All rights in respect of patents, designs and copyrights are reserved. ©2016	Document Type PUBLICITY	Title IW/MOW72 QUARTER TURN GEARBOX, 480/540/720 : 1, MANUAL INPUT : F30/FA30 OUTPUT
	LEEDS - UK www.rotork.com	Dimensions in mm 	Drawing Number PUB-IW72FBIRL-MAN-F30
		Sheet 1 of 1	Size A3