

INPUT FLANGE DETAILS							MOUNTING HOLES - BOLT CIRCLE (OFF CENTRES)								
INPUT FLANGE	FLANGE O/DIA. + THICKNESS	SHAFT DIA.	RECESS DIA.	RECESS DEPTH	HOLE DETAILS (OFF CENTRES)	KEY DETAILS	ISO 5211 / MSS SP-101 MOUNTING OPTION	HOLE DETAILS (22.5° OFF CENTRES)	STANDARD	MIN BORE	SQ KEY MAX BORE	SQ KEY SIZE	RECT. KEY MAX BORE	RECT. KEY SIZE	SQ BORE MAX
-	-	Ø50.00-0.05 (Ø1.969"-0.002")	-	-	-	14x9x55 (0.55"x0.35"x2.17")	ISO F25*	8 x M16 x 24 (0.94") DEEP ON Ø254.0 (Ø10.00") P.C.	BS4235	-	-	-	136	36 x 20	□ 108.8 (4.28")
-	-	-	-	-	-	-	FA25*	8 x 5/8" UNC x 24 (0.94") DEEP ON Ø254.0 (Ø10.00") P.C.	ANSI B17.1	-	4.875"	1.1/4" SQ.	5.125"	1.1/2" x 1"	
-	-	-	-	-	-	-	-	-	DIN 6885	-	-	-	136	36 x 20	

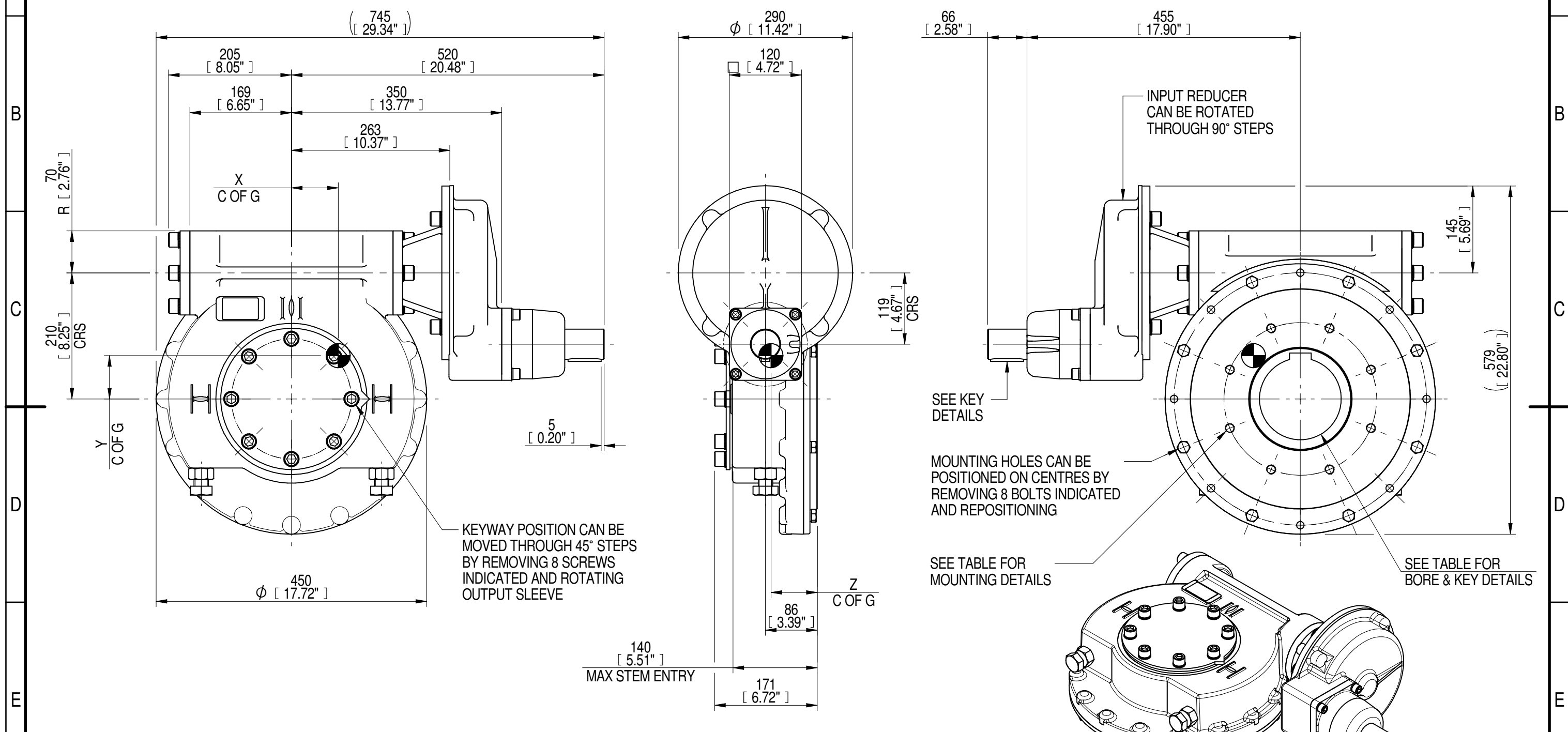

PLAN VIEW OF GEARBOX IN CLOSED POSITION SHOWING STANDARD KEYWAY POSITIONS. ALTERNATIVES AVAILABLE ON REQUEST

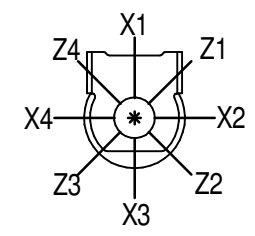

NOTES:  
 1. \* THREAD DEPTH DOES NOT MATCH ISO STANDARD  
 2. CENTRE OF GRAVITY POSITION IS INDICATIVE FOR STANDARD BUILD WHEN IN POSITION SHOWN

RATIO	TURNS TO CLOSE	M.A. ± 10%	WEIGHT (Kg)	MAX OUTPUT (Nm)	MAX INPUT (Nm)	X	Y	Z
360	90	142	128	26000	183	78	73	77
240	60	95	128	26000	274	78	73	77
180	45	71	128	26000	366	78	73	77
120	30	48	128	26000	542	78	72	77
DESCRIPTION			TORQUE		CENTRE OF GRAVITY			

AS PART OF CONTINUOUS PRODUCT DEVELOPMENT, ALL DETAILS SUBJECT TO CHANGE WITHOUT PRIOR NOTICE. FOR UP TO DATE DETAILS PLEASE VISIT [www.rotork.com](http://www.rotork.com)

	This drawing is confidential and is the property of Rotork Gears and must not be reproduced either wholly or partly. All rights in respect of patents, designs and copyrights are reserved. ©2016	Document Type <b>PUBLICITY</b>	Title <b>IW/MOW7 QUARTER TURN GEARBOX, 120/180/240/360 : 1, MANUAL INPUT : F25/FA25 OUTPUT</b>
		Dimensions in mm	
	<a href="http://www.rotork.com">www.rotork.com</a>		Iss. 01
Sheet 1 of 1		Size A3	