

INPUT FLANGE DETAILS							MOUNTING HOLES - BOLT CIRCLE (OFF CENTRES)								
INPUT FLANGE	FLANGE O/DIA. + THICKNESS	SHAFT DIA.	RECESS DIA.	RECESS DEPTH	HOLE DETAILS (OFF CENTRES)	KEY DETAILS	ISO 5211 / MSS SP-101 MOUNTING OPTION	HOLE DETAILS (22.5° OFF CENTRES)	STANDARD	MIN BORE	SQ KEY MAX BORE	SQ KEY SIZE	RECT. KEY MAX BORE	RECT. KEY SIZE	SQ BORE MAX
		Ø50.00-0.05 (Ø1.969"-0.002")				14x9x55 (0.55"x0.35"x2.17")	ISO F35*	8 x M30 x 36 (1.42") DEEP ON Ø356.0 (Ø14.02") P.C.	BS4235	-	-	-	157	40 x 22	□ 122.9 (4.84")
							FA35*	8 x 1" UNC x 36 (1.42") DEEP ON Ø355.6 (Ø14.00") P.C.	ANSI B17.1	-	5.625"	1.1/2" SQ.	6.00"	1.1/2" x 1"	
									DIN 6885	-	-	-	157	40 x 22	

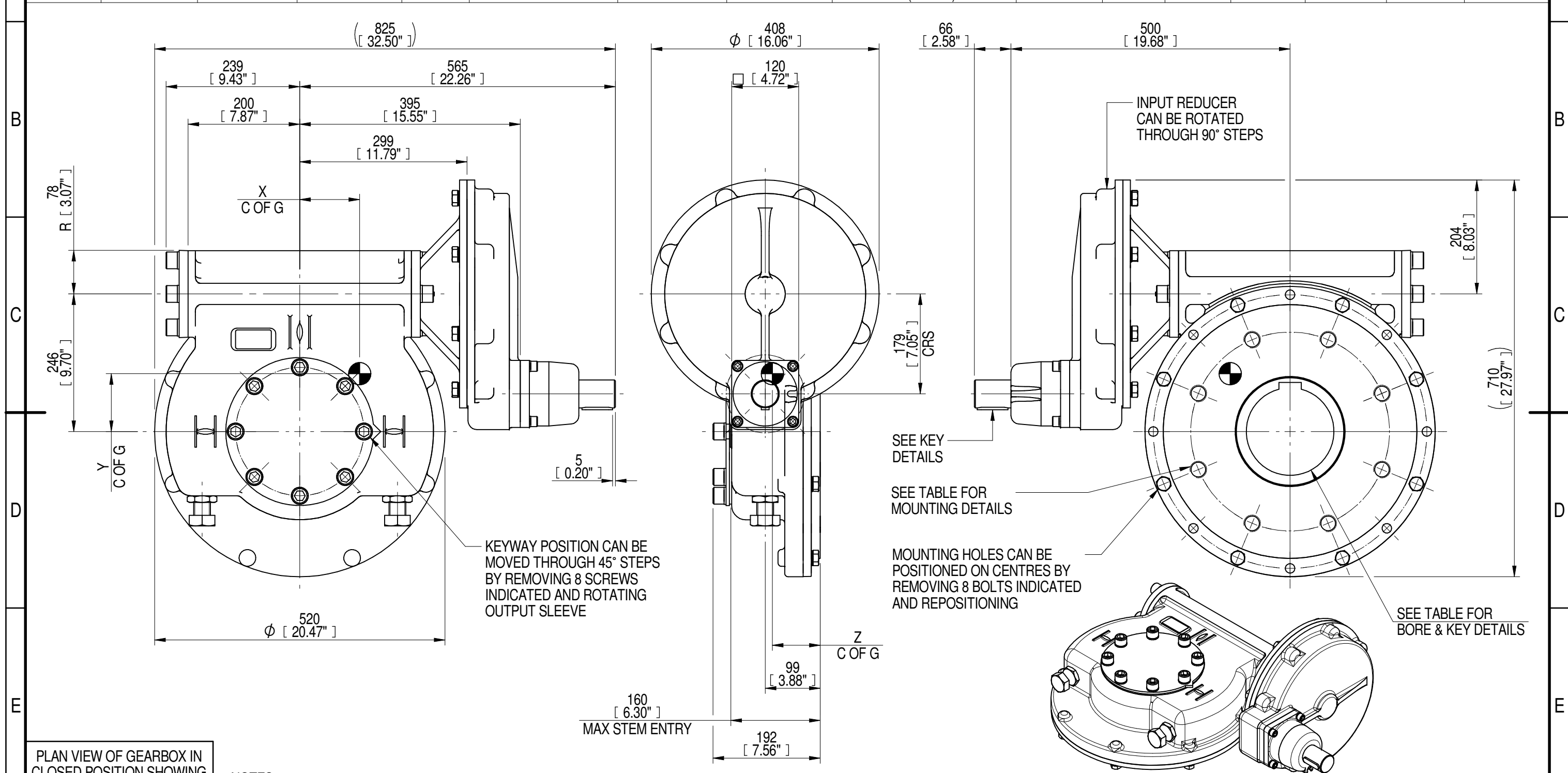

PLAN VIEW OF GEARBOX IN CLOSED POSITION SHOWING STANDARD KEYWAY POSITIONS. ALTERNATIVES AVAILABLE ON REQUEST



NOTES:  
 1. \* THREAD DEPTH DOES NOT MATCH ISO STANDARD  
 2. CENTRE OF GRAVITY POSITION IS INDICATIVE FOR STANDARD BUILD WHEN IN POSITION SHOWN

720	180	285	209	48100	169	110	105	86
540	135	214	207	48100	225	108	104	86
480	120	189	207	48100	254	107	104	86
RATIO	TURNS TO CLOSE	M.A. ± 10%	WEIGHT (Kg)	MAX OUTPUT (Nm)	MAX INPUT (Nm)	X	Y	Z
DESCRIPTION			TORQUE			CENTRE OF GRAVITY		

AS PART OF CONTINUOUS PRODUCT DEVELOPMENT, ALL DETAILS SUBJECT TO CHANGE WITHOUT PRIOR NOTICE. FOR UP TO DATE DETAILS PLEASE VISIT [www.rotork.com](http://www.rotork.com)

	Document Type <b>PUBLICITY</b>	Title <b>IW/MOW82 QUARTER TURN GEARBOX, 480/540/720 : 1, MANUAL INPUT : F35/ FA35</b> <b>OUTPUT</b> Drawing Number <b>PUB-IW82FBIRL-MAN-F35</b>	Iss. 01
	Dimensions in mm		
LEEDS - UK <a href="http://www.rotork.com">www.rotork.com</a>	This drawing is confidential and is the property of Rotork Gears and must not be reproduced either wholly or partly. All rights in respect of patents, designs and copyrights are reserved. ©2016	Sheet 1 of 1	Size A3