

1	2		3		4		5		6		7		8		
INPUT FLANGE DETAILS							MOUNTING HOLES - BOLT CIRCLE (OFF CENTRES)								
INPUT FLANGE	FLANGE O/DIA. + THICKNESS	SHAFT DIA.	RECESS DIA.	RECESS DEPTH	HOLE DETAILS (45° OFF CENTRES)	KEY DETAILS	ISO 5211 / MSS SP-101 MOUNTING OPTION	HOLE DETAILS (45° OFF CENTRES)	STANDARD	MIN BORE	SQ KEY MAX BORE	SQ KEY SIZE	RECT. KEY MAX BORE	RECT. KEY SIZE	SQ BORE MAX
ISO F10	Ø125 x 10 (Ø4.92" x 0.38")	Ø20.00-0.05 (Ø0.787"-0.002")	Ø70.05+0.15 (Ø2.758"+0.006")	4 (0.16")	4 x Ø10.5 ON Ø102.0 P.C. (4 x Ø0.41" ON Ø4.02" P.C.)	6x6x40 (0.24"x0.24"x1.57")	ISO F12*	4 x M12 x 16 (0.63") DEEP ON Ø125.0 (Ø4.92") P.C.	BS4235	-	-	-	64.0	18 x 11	□ 51.0 (2.01")
FA10							FA12*		4 x 1/2" UNC x 16 (0.63") DEEP ON Ø125.7 (Ø4.95") P.C.	ANSI B17.1	-	2.25"	1/2" SQ.	2.50"	
							DIN 6885	-	-	-	-	64.0	18 x 11		

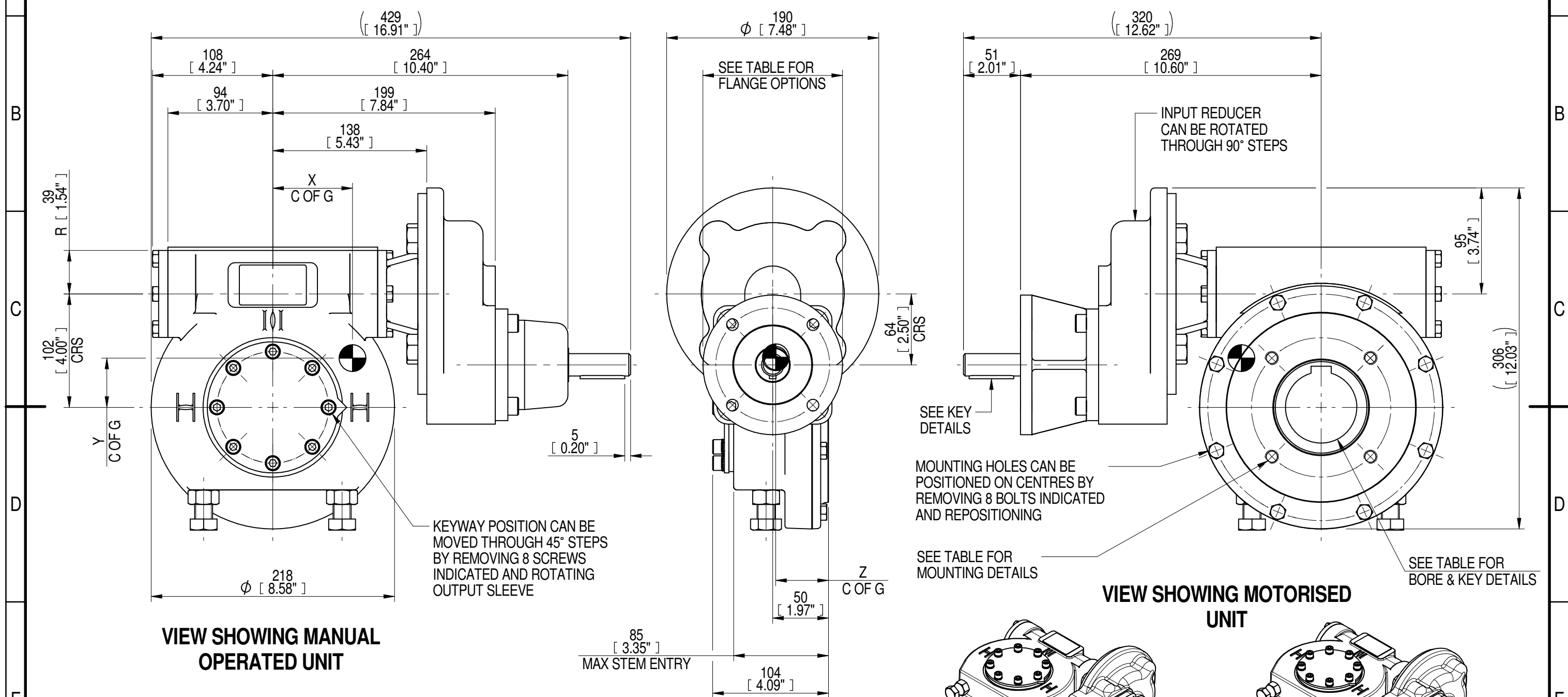

PLAN VIEW OF GEARBOX IN CLOSED POSITION SHOWING STANDARD KEYWAY POSITIONS. ALTERNATIVES AVAILABLE ON REQUEST

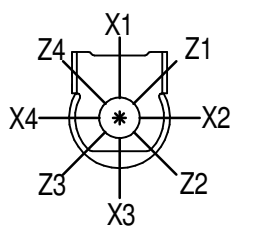

NOTES:
 1. * THREAD DEPTH DOES NOT MATCH ISO STANDARD
 2. CENTRE OF GRAVITY POSITION IS INDICATIVE FOR STANDARD BUILD WHEN IN POSITION SHOWN

RATIO	TURNS TO CLOSE	M.A. ± 10%	WEIGHT (Kg)	MAX OUTPUT (Nm)	MAX INPUT (Nm)	X	Y	Z
280	70	88	30	2264	26	73	45	47
210	53	66	30	2264	34	73	44	47
160	40	57	30	2617	46	73	45	47
140	35	44	29	2190	50	72	44	47
120	30	43	30	2617	61	72	45	47
80	20	29	30	2440	84	71	44	47

DESCRIPTION TORQUE CENTRE OF GRAVITY

AS PART OF CONTINUOUS PRODUCT DEVELOPMENT, ALL DETAILS SUBJECT TO CHANGE WITHOUT PRIOR NOTICE. FOR UP TO DATE DETAILS PLEASE VISIT www.rotork.com

	This drawing is confidential and is the property of Rotork Gears and must not be reproduced either wholly or partly. All rights in respect of patents, designs and copyrights are reserved. ©2016	Document Type PUBLICITY Dimensions in mm	Title IW/MOW4 QUARTER TURN GEARBOX, 80/120/140/160/210/280 : 1 MANUAL F10/ FA10/ INPUT : F12/ FA12 OUTPUT	Drawing Number PUB-IW4FBIRS-F10-F12	Iss. 01
	LEEDS - UK www.rotork.com		Sheet 1 of 1 Size A3		