

1	2		3		4		5		6			7		8	
INPUT FLANGE DETAILS							MOUNTING HOLES - BOLT CIRCLE (OFF CENTRES)								
INPUT FLANGE	FLANGE O/DIA. + THICKNESS	SHAFT DIA.	RECESS DIA.	RECESS DEPTH	HOLE DETAILS (45° OFF CENTRES)	KEY DETAILS	ISO 5211 / MSS SP-101 MOUNTING OPTION	HOLE DETAILS (45° OFF CENTRES)	STANDARD	MIN BORE	SQ KEY MAX BORE	SQ KEY SIZE	RECT. KEY MAX BORE	RECT. KEY SIZE	SQ BORE MAX
ISO F10	Ø125 x 10 (Ø4.92" x 0.38")	Ø20.00-0.05 (Ø0.787"-0.002")	Ø70.05+0.15 (Ø2.758"+0.006")	4 (0.16")	4 x Ø10.5 ON Ø102.0 P.C. (4 x Ø0.41" ON Ø4.02" P.C.)	6x6x40 (0.24"x0.24"x1.57")	ISO F14*	4 x M16 x 20 (0.79") DEEP ON Ø140.0 (Ø5.51") P.C.	BS4235	-	-	-	76.0	22 x 14	□ 62.0 (2.44")
FA10			Ø58.70+0.15 (Ø2.311"+0.006")						ANSI B17.1	-	2.75"	3/4" SQ.	3.00"	3/4" x 1/2"	
							DIN 6885	-	-	-	-	76.0	22 x 14		

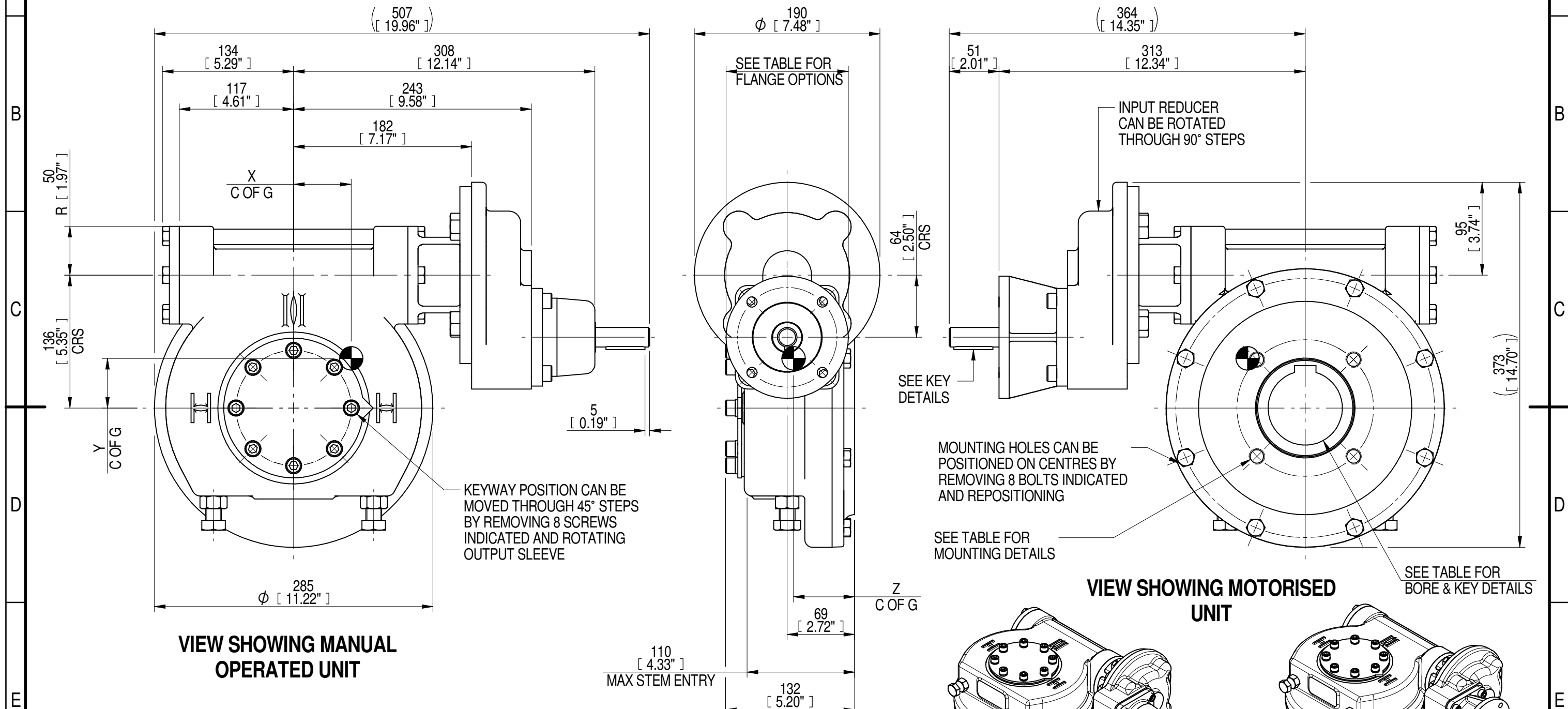

PLAN VIEW OF GEARBOX IN CLOSED POSITION SHOWING STANDARD KEYWAY POSITIONS. ALTERNATIVES AVAILABLE ON REQUEST

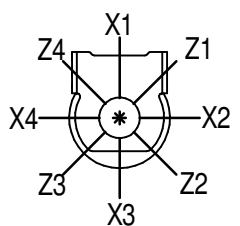

NOTES:
 1. * THREAD DEPTH DOES NOT MATCH ISO STANDARD
 2. CENTRE OF GRAVITY POSITION IS INDICATIVE FOR STANDARD BUILD WHEN IN POSITION SHOWN

280	70	88	49	3701	42	60	51	62
210	53	66	49	3701	56	60	51	62
160	40	65	50	4447	68	60	52	62
140	35	44	49	3701	84	59	50	62
120	30	48	50	4447	93	60	51	62
80	20	32	50	4447	139	59	51	62
RATIO	TURNS TO CLOSE	M.A. ± 10%	WEIGHT (Kg)	MAX OUTPUT (Nm)	MAX INPUT (Nm)	X	Y	Z
DESCRIPTION			TORQUE		CENTRE OF GRAVITY			

AS PART OF CONTINUOUS PRODUCT DEVELOPMENT, ALL DETAILS SUBJECT TO CHANGE WITHOUT PRIOR NOTICE. FOR UP TO DATE DETAILS PLEASE VISIT www.rotork.com

rotork Gears
 LEEDS - UK
www.rotork.com

This drawing is confidential and is the property of Rotork Gears and must not be reproduced either wholly or partly. All rights in respect of patents, designs and copyrights are reserved. ©2016

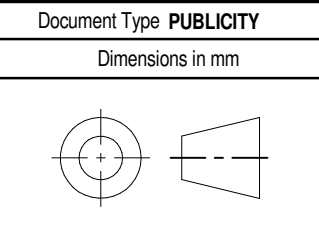

Document Type PUBLICITY	Title IW/MOW5 QUARTER TURN GEARBOX, 80/120/140/160/210/280 : 1 MANUAL F10/ FA10 INPUT : F14/ FA14 OUPUT	Drawing Number PUB-IW5FBIRS-F10-F14	Iss. 01
Dimensions in mm			
Sheet 1 of 1		Size A3	