

1	2		3		4		5		6			7		8	
INPUT FLANGE DETAILS							MOUNTING HOLES - BOLT CIRCLE (OFF CENTRES)								
INPUT FLANGE	FLANGE O/DIA. + THICKNESS	SHAFT DIA.	RECESS DIA.	RECESS DEPTH	HOLE DETAILS (45° OFF CENTRES)	KEY DETAILS	ISO 5211 / MSS SP-101 MOUNTING OPTION	HOLE DETAILS (45° OFF CENTRES)	STANDARD	MIN BORE	SQ KEY MAX BORE	SQ KEY SIZE	RECT. KEY MAX BORE	RECT. KEY SIZE	SQ BORE MAX
ISO F10	Ø125 x 16 (Ø4.92" x 0.63")	Ø20.00-0.05 (Ø0.787"-0.002")	Ø70.05+0.15 (Ø2.758"+0.006")	4 (0.16")	4 x Ø10.5 ON Ø102.0 P.C. (4 x Ø0.41" ON Ø4.02" P.C.)	6x6x40 (0.24"x0.24"x1.57")	ISO F16*	4 x M20 x 20 (0.79") DEEP ON Ø165.0 (Ø6.50") P.C.	BS4235	-	-	-	102	28 x 16	□ 83.3 (3.28")
FA10			BS46						-	3.625"	1" SQ.	3.75"	1" x 3/4"		
	ANSI B17.1	-	3.75"	7/8" SQ.	3.875"	1" x 3/4"									
	DIN 6885	-	-	-	102	28 x 16									

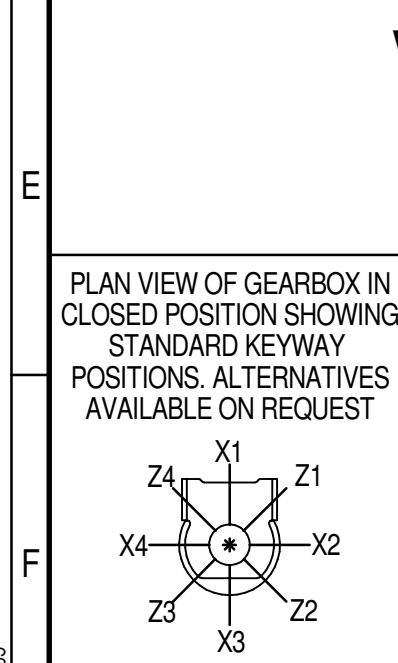
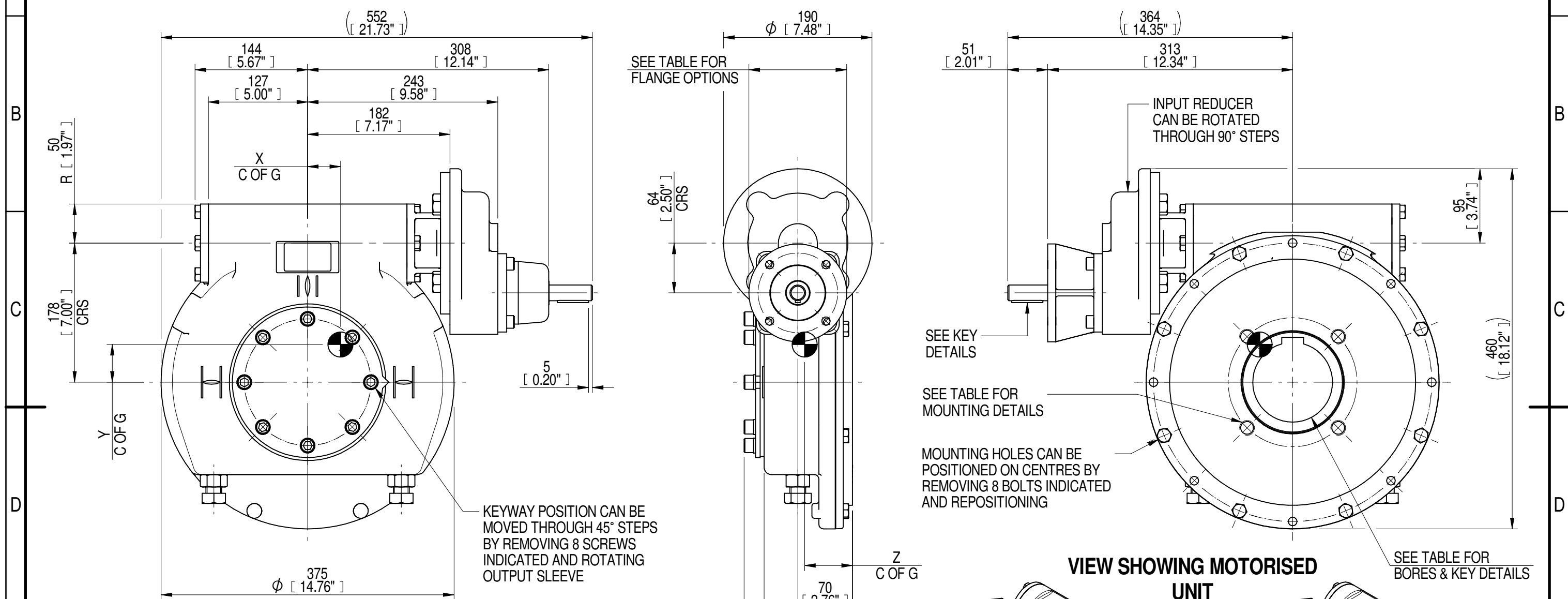

NOTES:
 1. * THREAD DEPTH DOES NOT MATCH ISO STANDARD
 2. CENTRE OF GRAVITY POSITION IS INDICATIVE FOR STANDARD BUILD WHEN IN POSITION SHOWN

RATIO	TURNS TO CLOSE	M.A.±10%	WEIGHT (Kg)	MAX OUTPUT (Nm)	MAX INPUT (Nm)	X	Y	Z
280	70	88	70	9924	113	43	49	61
210	53	66	70	9274	141	42	48	61
140	35	44	70	9274	211	42	48	61

DESCRIPTION TORQUE CENTRE OF GRAVITY

AS PART OF CONTINUOUS PRODUCT DEVELOPMENT, ALL DETAILS SUBJECT TO CHANGE WITHOUT PRIOR NOTICE. FOR UP TO DATE DETAILS PLEASE VISIT www.rotork.com

rotork Gears
 LEEDS - UK
www.rotork.com

This drawing is confidential and is the property of Rotork Gears and must not be reproduced either wholly or partly. All rights in respect of patents, designs and copyrights are reserved. ©2016

Document Type **PUBLICITY**
 Dimensions in mm

Title
IW/MOW6 QUARTER TURN GEARBOX, 140/210/280 :1 MANUAL F10/ FA10 INPUT: F16/ FA16 OUTPUT

Drawing Number
PUB-IW6FBIRS-F10-F16

Sheet 1 of 1 Size A3