

1	2		3		4		5		6			7		8	
INPUT FLANGE DETAILS							MOUNTING HOLES - BOLT CIRCLE (OFF CENTRES)								
INPUT FLANGE	FLANGE O/DIA. + THICKNESS	SHAFT DIA.	RECESS DIA.	RECESS DEPTH	HOLE DETAILS (45° OFF CENTRES)	KEY DETAILS	ISO 5211 / MSS SP-101 MOUNTING OPTION	HOLE DETAILS (22.5° OFF CENTRES)	STANDARD	MIN BORE	SQ KEY MAX BORE	SQ KEY SIZE	RECT. KEY MAX BORE	RECT. KEY SIZE	SQ BORE MAX
ISO F14	Ø175 x 15 (Ø6.89" x 0.59")	Ø30.00-0.05 (Ø1.181"-0.002")	Ø100.05+0.15 (Ø3.939"+0.006")	5 (0.20")	4 x Ø16.5 ON Ø140.0 P.C. (4 x Ø0.65" ON Ø5.51" P.C.)	8x7x55 (0.31"x0.28"x2.17")	ISO F30*	8 x M20 x 24 (0.94") DEEP ON Ø298.00 (Ø11.73") P.C.	BS4235	-	-	-	136	36 x 20	□ 108.8 (4.28")
FA14			BS46						-	4.875"	1.1/4" SQ.	5.125"	1.1/2" x 1"		
	ANSI B17.1	-	4.875"	1.1/4" SQ.	5.25"	1.1/4" x 7/8"									
			Ø95.25+0.15 (Ø3.750"+0.006")				FA30*	8 x 3/4" UNC x 24 (0.94") DEEP ON Ø298.45 (Ø11.75") P.C.	DIN 6885	-	-	-	136	36 x 20	

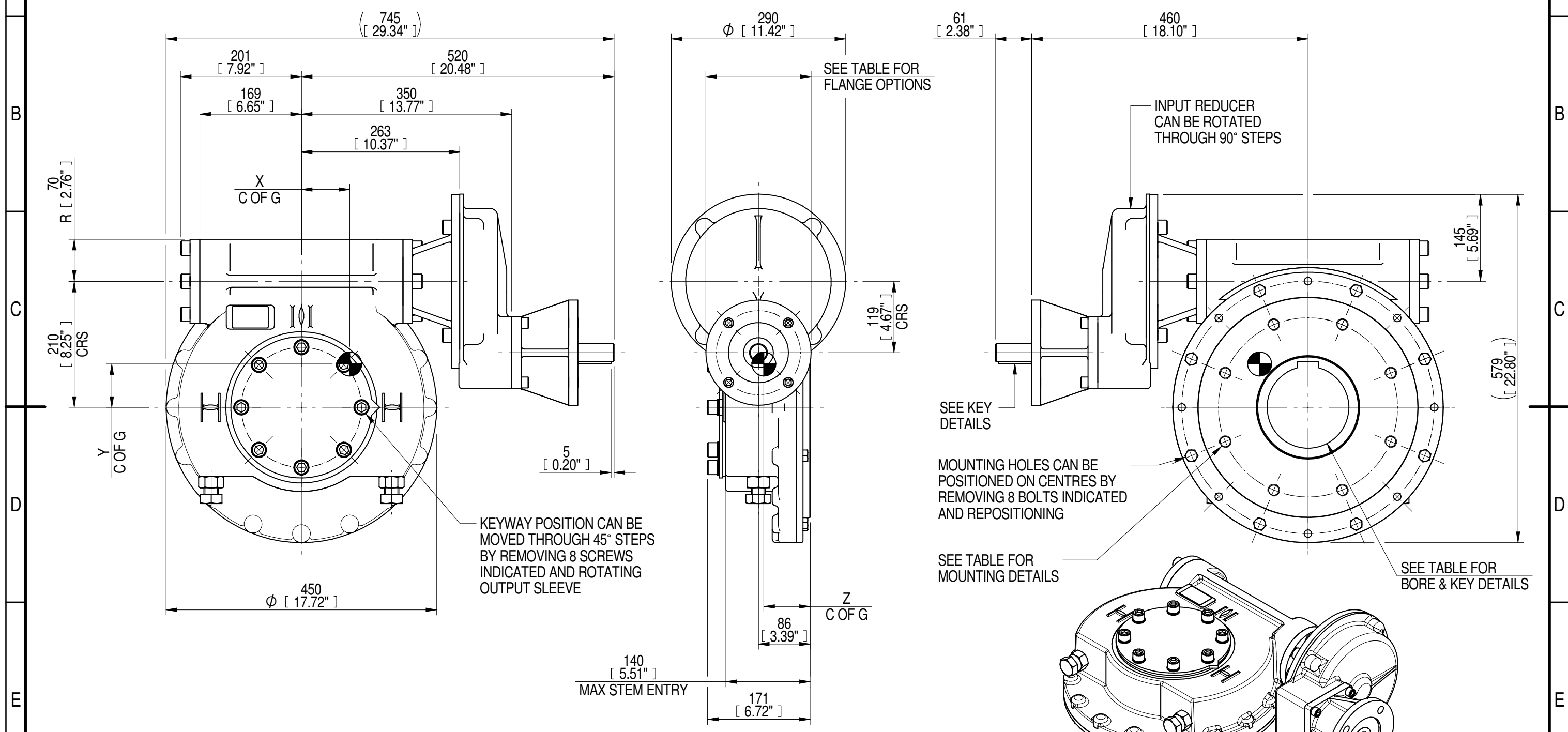

PLAN VIEW OF GEARBOX IN CLOSED POSITION SHOWING STANDARD KEYWAY POSITIONS. ALTERNATIVES AVAILABLE ON REQUEST

- NOTES:
- * THREAD DEPTH DOES NOT MATCH ISO STANDARD
 - CENTRE OF GRAVITY POSITION IS INDICATIVE FOR STANDARD BUILD WHEN IN POSITION SHOWN

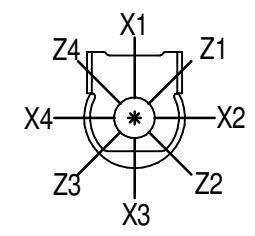

RATIO	TURNS TO CLOSE	M.A. ± 10%	WEIGHT (Kg)	MAX OUTPUT (Nm)	MAX INPUT (Nm)	X	Y	Z
360	90	142	129	15253	107	81	74	77
240	60	95	129	15253	161	80	73	77
180	45	71	129	13558	191	80	73	77
120	30	48	129	13558	282	80	72	77

AS PART OF CONTINUOUS PRODUCT DEVELOPMENT, ALL DETAILS SUBJECT TO CHANGE WITHOUT PRIOR NOTICE. FOR UP TO DATE DETAILS PLEASE VISIT www.rotork.com

	Document Type PUBLICITY	Title IW/MOW7 QUARTER TURN GEARBOX, 120/180/240/360 : 1, F14/ FA14 INPUT : F30/FA30 OUTPUT Drawing Number PUB-IW7FBIRS-F14-F30	Iss. 01
	Dimensions in mm		
LEEDS - UK www.rotork.com	This drawing is confidential and is the property of Rotork Gears and must not be reproduced either wholly or partly. All rights in respect of patents, designs and copyrights are reserved. ©2016		