

INPUT FLANGE DETAILS							MOUNTING HOLES - BOLT CIRCLE (OFF CENTRES)								
INPUT FLANGE	FLANGE O/DIA. + THICKNESS	SHAFT DIA.	RECESS DIA.	RECESS DEPTH	HOLE DETAILS (45° OFF CENTRES)	KEY DETAILS	ISO 5211 / MSS SP-101 MOUNTING OPTION	HOLE DETAILS (22.5° OFF CENTRES)	STANDARD	MIN BORE	SQ KEY MAX BORE	SQ KEY SIZE	RECT. KEY MAX BORE	RECT. KEY SIZE	SQ BORE MAX
ISO F25	Ø300 x 20 (Ø11.81" x 0.787")	Ø50.00-0.05 (Ø1.969"-0.002")	Ø200.10+0.10 (Ø7.878"+0.004")	5 (0.20")	8 x Ø16.5 ON Ø254.0 P.C. (8 x Ø0.65" ON Ø10.00" P.C.)	14x9x55 (0.55"x0.35"x2.17")	ISO F30*	8 x M20 x 30 (1.18") DEEP ON Ø298.0 (Ø11.73") P.C.	BS4235	-	-	-	157	40 x 22	□ 122.9 (4.84")
FA25							8 x 3/4" UNC x 30 (1.18") DEEP ON Ø298.0 (Ø11.73") P.C.	ANSI B17.1	-	5.625"	1.1/2" SQ.	6.00"	1.1/2" x 1"		
							DIN 6885	-	-	-	-	157	40 x 22		

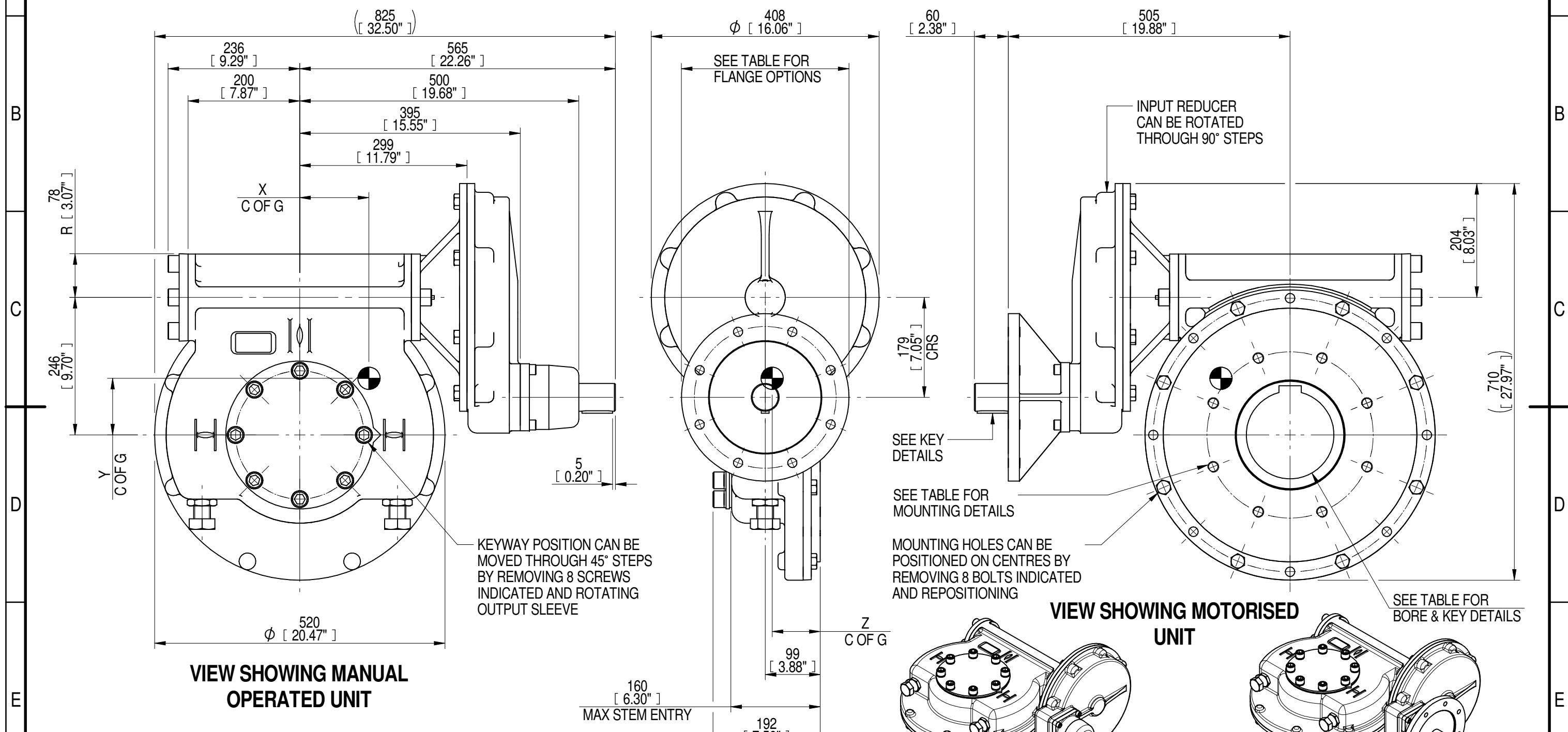

PLAN VIEW OF GEARBOX IN CLOSED POSITION SHOWING STANDARD KEYWAY POSITIONS. ALTERNATIVES AVAILABLE ON REQUEST

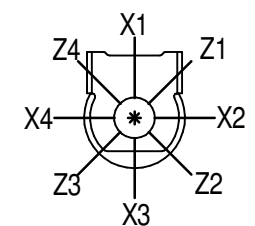

NOTES:
 1. * THREAD DEPTH DOES NOT MATCH ISO STANDARD
 2. CENTRE OF GRAVITY POSITION IS INDICATIVE FOR STANDARD BUILD WHEN IN POSITION SHOWN

720	180	285	219	26031	91	126	103	86
540	135	214	217	26031	122	124	102	86
480	120	189	217	26031	138	124	101	86
RATIO	TURNS TO CLOSE	M.A. ± 10%	WEIGHT (Kg)	MAX OUTPUT (Nm)	MAX INPUT (Nm)	X	Y	Z
DESCRIPTION			TORQUE		CENTRE OF GRAVITY			

AS PART OF CONTINUOUS PRODUCT DEVELOPMENT, ALL DETAILS SUBJECT TO CHANGE WITHOUT PRIOR NOTICE. FOR UP TO DATE DETAILS PLEASE VISIT www.rotork.com

rotork Gears
 LEEDS - UK
www.rotork.com

This drawing is confidential and is the property of Rotork Gears and must not be reproduced either wholly or partly. All rights in respect of patents, designs and copyrights are reserved. ©2016

Document Type **PUBLICITY**
 Dimensions in mm

Title
IW/MOW8 QUARTER TURN GEARBOX, 480/540/720 : 1, MANUAL, F25/ FA25 INPUT : F30/ FA30 OUTPUT

Drawing Number
PUB-IW8FBIRL-F25-F30

Sheet 1 of 1 Size A3